

# Application Note: Controlled Polymerization of N-Alkylaniline Derivatives

**Author:** BenchChem Technical Support Team. **Date:** April 2026

## Compound of Interest

Compound Name: *N*-(butan-2-yl)-3-(methylsulfanyl)aniline  
Cat. No.: B12095920

[Get Quote](#)

## Abstract

This guide details the synthesis protocols for poly(*N*-methylaniline) (PNMA) and poly(*N*-ethylaniline) (PNEA), focusing on the critical balance between processability and electrical conductivity. While the parent polymer, polyaniline (PANI), offers high conductivity, its insolubility limits its utility.[1][2][3] *N*-alkylation solves the solubility challenge but introduces steric strain that perturbs the conjugated backbone.[4] This document provides optimized chemical and electrochemical protocols designed to maximize chain linearity and conductivity despite these steric constraints.

## Part 1: Mechanistic Insight & Steric Constraints

To synthesize high-quality *N*-alkylated polyanilines, one must understand the Steric-Electronic Trade-off.

- **The Mechanism:** The polymerization proceeds via an oxidative radical cation mechanism. The oxidant extracts an electron from the nitrogen lone pair, forming a radical cation. These radicals couple primarily in a para-directed head-to-tail fashion (

).

- The Steric Challenge: Unlike PANI, the N-alkyl group (methyl, ethyl, etc.) creates steric bulk. This forces the phenyl rings to twist out of planarity to accommodate the substituent.
  - Consequence: The torsion angle between rings increases
    - orbital overlap decreases
    - effective conjugation length shortens
    - Conductivity drops.
- The Solution: Low-temperature synthesis and slow oxidant addition are strictly required to minimize high-energy "head-to-head" coupling defects, which further reduce conductivity.

## Visualization: Oxidative Cycle & Steric Twist

The following diagram illustrates the propagation cycle and the steric conflict introduced by the alkyl group (

).

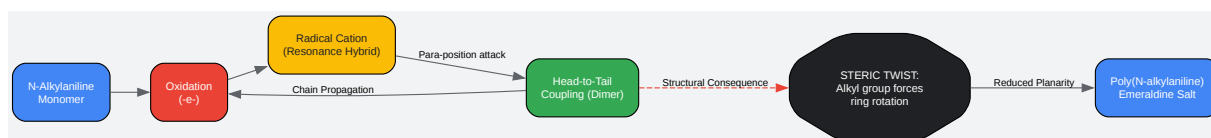

[Click to download full resolution via product page](#)

Caption: The oxidative cycle showing how N-alkyl substitution introduces steric torsion, reducing the final polymer's conjugation length.

## Part 2: Chemical Oxidative Polymerization (Bulk Synthesis)

This protocol is optimized for Poly(N-methylaniline) (PNMA) but is applicable to N-ethyl derivatives with minor solubility adjustments.

## Reagents & Equipment[5]

- Monomer: N-methylaniline (Distilled under reduced pressure before use to remove colored oxidation products).
- Oxidant: Ammonium Persulfate (APS), (NH<sub>4</sub>)<sub>2</sub>S<sub>2</sub>O<sub>8</sub>.
- Acid Dopant: 1.0 M Hydrochloric Acid (HCl).
- Solvent: Deionized Water (18 MΩ·cm).
- Equipment: Jacketed reactor or ice bath, mechanical stirrer (magnetic stirring is insufficient for high viscosity), filtration setup.

## Protocol Steps

Step 1: Monomer Salt Formation Dissolve 0.1 mol of N-methylaniline in 100 mL of 1.0 M HCl.

- Observation: The solution should be clear to pale yellow. If dark, the monomer is impure.
- Why: Protonation of the amine protects it, but the equilibrium allows enough free amine for the oxidation initiation.

Step 2: Thermal Equilibration (Critical) Cool the monomer solution to 0°C - 5°C.

- Expert Insight: N-alkylanilines react faster than aniline. Higher temperatures favor side reactions (ortho-coupling) and shorter chain lengths.

Step 3: Oxidant Addition Dissolve 0.1 mol APS (stoichiometric ratio 1:1) in 50 mL of 1.0 M HCl. Add this solution dropwise to the monomer solution over 30–60 minutes.

- Self-Validating Signal:
  - : Clear.
  - : Pink/Violet (formation of oligomers).
  - : Dark Green/Black precipitate (Emeraldine salt formation).

Step 4: Post-Polymerization Continue stirring at 0–5°C for 6 hours, then allow to stand for 18 hours.

Step 5: Purification (The Dedoping Cycle)

- Filter the dark green precipitate.
- Wash 1: Wash with 1.0 M HCl until filtrate is colorless (removes monomer).
- Dedoping: Stir the filter cake in 0.1 M Ammonium Hydroxide (NH<sub>4</sub>OH) for 2 hours. The polymer turns Blue/Violet (Emeraldine Base).
- Extraction: Filter and dry. Extract the base with Tetrahydrofuran (THF) or Chloroform. This separates the high-molecular-weight polymer (soluble) from crosslinked byproducts (insoluble).
- Redoping (Optional): Cast the film and treat with acid vapor to restore conductivity (Green color returns).

## Part 3: Electrochemical Deposition (Thin Film)

For sensor applications, electrochemical synthesis provides superior control over film thickness and morphology.

### Setup Configuration

- Working Electrode: Platinum disc, Glassy Carbon, or ITO.

- Reference: Ag/AgCl (3M KCl).[5]
- Counter: Platinum wire.
- Electrolyte: 0.1 M Monomer + 1.0 M H

SO

(Sulfuric acid yields more durable films than HCl).

## Protocol: Cyclic Voltammetry (CV) Growth[7]

- Parameters:
  - Scan Range: -0.2 V to +0.9 V (vs Ag/AgCl).
  - Scan Rate: 50 mV/s.
  - Cycles: 10–20 (depending on desired thickness).
- Process Logic:
  - Forward Scan (>0.7V): Monomer oxidation occurs. Radical cations adsorb and couple.
  - Reverse Scan: Reduction of the deposited film.
  - Subsequent Scans: Current peaks increase, indicating autocatalytic growth on the conductive polymer surface.

## Visualization: Electrochemical Workflow

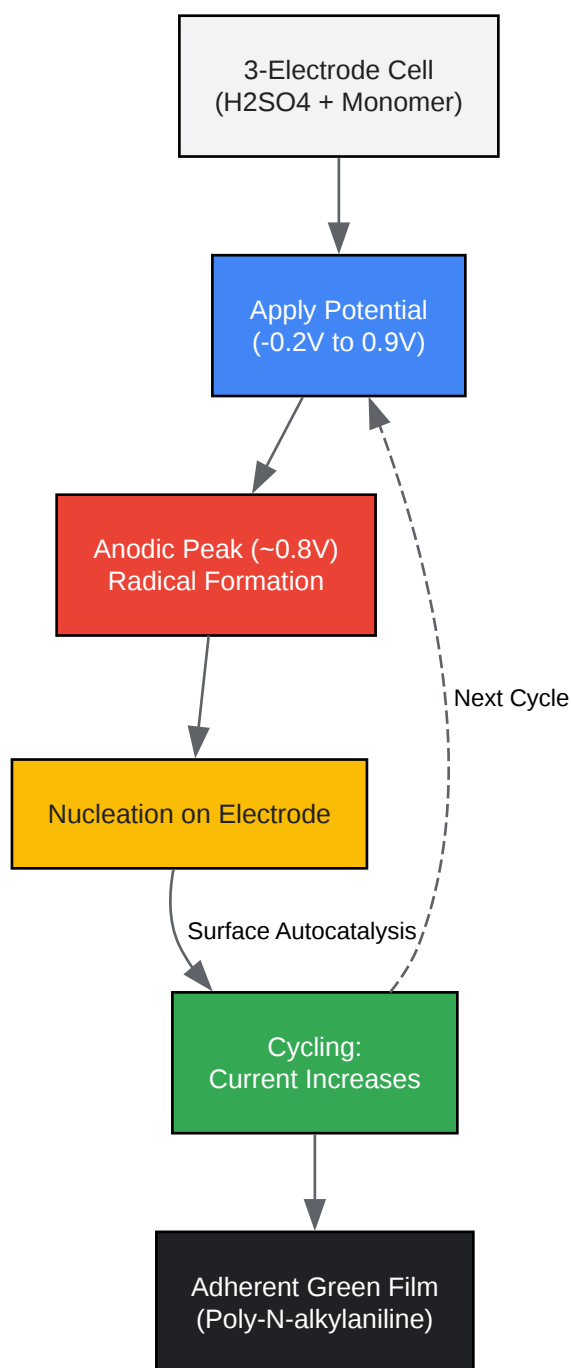

[Click to download full resolution via product page](#)

Caption: Electrochemical workflow showing the cyclical growth of the polymer film via anodic oxidation.

## Part 4: Characterization & Data Interpretation

N-alkylation drastically alters the physical properties compared to standard PANI.[4] Use the table below to validate your synthesis.

## Comparative Properties Table

Property	Polyaniline (PANI)	Poly(N-methylaniline) (PNMA)	Poly(N-ethylaniline) (PNEA)
Conductivity (S/cm)	1.0 – 10.0	–	–
Solubility (Base form)	Insoluble (NMP only)	Soluble (THF, CHCl <sub>3</sub> , DMF)	Highly Soluble (THF, Acetone)
UV-Vis	~800 nm (Polaron band)	~600–700 nm (Blue-shifted)	~550–650 nm (Further shift)
Steric Effect	Low	Moderate (Twisted backbone)	High (Highly twisted)
Processability	Poor	Good	Excellent

## Troubleshooting Guide

- Issue: Low Conductivity.
  - Cause: Over-oxidation (degradation) or insufficient doping.
  - Fix: Ensure oxidant:monomer ratio does not exceed 1.25:1. Verify pH is < 1.0 during synthesis.
- Issue: Poor Film Adhesion (Electrochemical).
  - Cause: Scan rate too fast or monomer concentration too high (bulk precipitation).
  - Fix: Lower scan rate to 20 mV/s; reduce monomer concentration to 0.05 M.
- Issue: Low Solubility in THF.

- Cause: Crosslinking.
- Fix: Lower the synthesis temperature. Crosslinking is thermally activated.

## References

- Genies, E. M., et al. (1990). "Polyaniline: A Historical Survey." Synthetic Metals.
- Kang, E. T., et al. (1998). "Polyaniline and its derivatives: synthesis and properties." Progress in Polymer Science.
- Stejskal, J., & Gilbert, R. G. (2002). "Polyaniline.<sup>[1][4][6][5][7][8][9][10][11][12][13][14]</sup> Preparation of a conducting polymer." Pure and Applied Chemistry.
- Gospodinova, N., & Terlemezyan, L. (1998). "Conducting polymers prepared by oxidative polymerization: Polyaniline." Progress in Polymer Science.
- Chevalier, J. W., et al. (1992). "Synthesis and properties of poly(N-alkylanilines)." Macromolecules.

### Need Custom Synthesis?

BenchChem offers custom synthesis for rare earth carbides and specific isotopic labeling.

Email: [info@benchchem.com](mailto:info@benchchem.com) or [Request Quote Online](#).

## Sources

- [1. Synthesis and Characterization of Hollow-Sphered Poly\(N-methylaniline\) for Enhanced Electrical Conductivity Based on the Anionic Surfactant Templates and Doping - PMC \[pmc.ncbi.nlm.nih.gov\]](#)
- [2. pubs.rsc.org \[pubs.rsc.org\]](#)
- [3. materialsciencejournal.org \[materialscejournal.org\]](#)
- [4. pdf.benchchem.com \[pdf.benchchem.com\]](#)
- [5. connectsci.au \[connectsci.au\]](#)
- [6. pubs.aip.org \[pubs.aip.org\]](#)

- [7. web.itu.edu.tr](http://web.itu.edu.tr) [[web.itu.edu.tr](http://web.itu.edu.tr)]
- [8. researchgate.net](http://researchgate.net) [[researchgate.net](http://researchgate.net)]
- [9. quora.com](http://quora.com) [[quora.com](http://quora.com)]
- [10. web.itu.edu.tr](http://web.itu.edu.tr) [[web.itu.edu.tr](http://web.itu.edu.tr)]
- [11. researchgate.net](http://researchgate.net) [[researchgate.net](http://researchgate.net)]
- [12. cpsm.kpi.ua](http://cpsm.kpi.ua) [[cpsm.kpi.ua](http://cpsm.kpi.ua)]
- [13. individual.utoronto.ca](http://individual.utoronto.ca) [[individual.utoronto.ca](http://individual.utoronto.ca)]
- [14. scispace.com](http://scispace.com) [[scispace.com](http://scispace.com)]
- To cite this document: BenchChem. [Application Note: Controlled Polymerization of N-Alkylaniline Derivatives]. BenchChem, [2026]. [Online PDF]. Available at: [<https://www.benchchem.com/product/b12095920/docs#application-note-controlled-polymerization-of-n-alkylaniline-derivatives>]

---

#### Disclaimer & Data Validity:

The information provided in this document is for Research Use Only (RUO) and is strictly not intended for diagnostic or therapeutic procedures. While BenchChem strives to provide accurate protocols, we make no warranties, express or implied, regarding the fitness of this product for every specific experimental setup.

**Technical Support:** The protocols provided are for reference purposes. Unsure if this reagent suits your experiment?

**Need Industrial/Bulk Grade?** [Request Custom Synthesis Quote](#)

## BenchChem

Our mission is to be the trusted global source of essential and advanced chemicals, empowering scientists and researchers to drive progress in science and industry.

#### Contact

Address: 3281 E Guasti Rd

Ontario, CA 91761, United States

Phone: (601) 213-4426

Email: [info@benchchem.com](mailto:info@benchchem.com)

Contact our Ph.D. Support Team for a compatibility check