

# Technical Support Center: (+)-Norcisapride Analytical Methods

**Author:** BenchChem Technical Support Team. **Date:** April 2026

## Compound of Interest

Compound Name: (+)-Norcisapride

CAS No.: 83863-69-8

Cat. No.: B1209443

[Get Quote](#)

This technical support center provides a comprehensive guide for researchers, scientists, and drug development professionals working with **(+)-Norcisapride**. It includes detailed troubleshooting guides and frequently asked questions (FAQs) in a user-friendly question-and-answer format to address specific issues that may be encountered during experimental analysis.

## Frequently Asked Questions (FAQs)

### General

- What is **(+)-Norcisapride**? **(+)-Norcisapride** is the major metabolite of cisapride, a gastroprokinetic agent. It is formed primarily through oxidative N-dealkylation of the piperidine nitrogen of cisapride.<sup>[1]</sup>

### HPLC Analysis

- What is a typical starting HPLC method for Norcisapride analysis? A common method utilizes a reversed-phase C8 column with a mobile phase consisting of a methanol and phosphate buffer mixture. Fluorescence detection is often employed for enhanced sensitivity.<sup>[2]</sup>

- I am seeing peak tailing for my **(+)-Norcisapride** peak. What are the common causes? Peak tailing for basic compounds like **(+)-Norcisapride** is often due to secondary interactions with residual silanols on the silica-based stationary phase. Other causes can include column contamination, inappropriate mobile phase pH, or column overload.[3]
- My resolution between **(+)-Norcisapride** and other components is poor. How can I improve it? To improve resolution, you can optimize the mobile phase composition (e.g., organic modifier percentage, pH), decrease the flow rate, or adjust the column temperature.[3] If analyzing enantiomers, selecting the appropriate chiral stationary phase is critical.[3]

### LC-MS/MS Analysis

- What are some general considerations for developing an LC-MS/MS method for **(+)-Norcisapride**? For basic compounds like **(+)-Norcisapride**, electrospray ionization (ESI) in positive ion mode is typically used.[4][5] The mobile phase should be compatible with MS detection, often requiring the use of volatile additives like formic acid or ammonium formate. [5][6]
- I am experiencing significant signal suppression for **(+)-Norcisapride** in my plasma samples. What can I do? Matrix effects, particularly ion suppression, are common in bioanalysis.[7] To mitigate this, you can improve sample preparation to remove interfering matrix components (e.g., phospholipids), optimize chromatography to separate **(+)-Norcisapride** from co-eluting substances, or use a stable isotope-labeled internal standard.[7]

### GC-MS Analysis

- Is GC-MS a suitable technique for **(+)-Norcisapride** analysis? Direct GC-MS analysis of **(+)-Norcisapride** can be challenging due to its polarity and potential for thermal degradation. Derivatization is often necessary to improve its volatility and chromatographic properties.[8][9]
- What derivatization reagents are commonly used for compounds similar to **(+)-Norcisapride**? Silylation reagents (e.g., BSTFA, MTBSTFA) or acylation reagents are commonly used to derivatize amine and amide functional groups, making them more amenable to GC-MS analysis.[8][9]

## Troubleshooting Guides

### HPLC Method for (+)-Norcisapride

This guide focuses on troubleshooting a reversed-phase HPLC method with fluorescence detection.

#### Problem 1: No Peak or Very Small Peak for (+)-Norcisapride

Possible Cause	Suggested Solution
Incorrect Wavelengths	Verify the excitation and emission wavelengths on the fluorescence detector are correctly set for (+)-Norcisapride.
Sample Degradation	Ensure proper sample storage conditions (e.g., protected from light, appropriate temperature) to prevent degradation. <sup>[10][11]</sup> Prepare fresh standards and samples.
Injection Issue	Check the autosampler for proper functioning, including the syringe and injection valve. Manually inject a standard to confirm system performance.
Mobile Phase Preparation	Confirm the correct composition and pH of the mobile phase. Ensure all components are fully dissolved and the mobile phase is properly degassed.

#### Problem 2: Poor Peak Shape (Tailing, Fronting, Splitting)

Possible Cause	Suggested Solution
Peak Tailing	Add a competitor for active sites, such as triethylamine (TEA), to the mobile phase.[2] Use a column with end-capping or a different stationary phase. Ensure the mobile phase pH is appropriate for the basic nature of (+)-Norcisapride.
Peak Fronting	This may indicate column overload. Reduce the injection volume or dilute the sample.
Split Peaks	A partially blocked column frit or a void at the column inlet could be the cause. Try back-flushing the column. If the problem persists, replace the column.

### Problem 3: Shifting Retention Times

Possible Cause	Suggested Solution
Inconsistent Mobile Phase	Prepare fresh mobile phase, ensuring accurate measurements of all components. Use a buffer to maintain a stable pH.
Fluctuating Column Temperature	Use a column oven to maintain a consistent temperature.
Column Equilibration	Ensure the column is adequately equilibrated with the mobile phase before starting the analytical run. Chiral columns may require longer equilibration times.[3]
Pump Issues	Check for leaks and ensure the pump is delivering a consistent flow rate.

## LC-MS/MS Method for (+)-Norcisapride

This guide addresses common issues in the development and execution of an enantioselective LC-MS/MS method.

### Problem 1: Low Signal Intensity or Poor Sensitivity

Possible Cause	Suggested Solution
Suboptimal Ionization	Optimize ESI source parameters (e.g., capillary voltage, gas flow, temperature). Ensure the mobile phase pH is conducive to forming the desired protonated molecule $[M+H]^+$ .
Matrix-Induced Ion Suppression	Implement a more effective sample preparation technique (e.g., solid-phase extraction) to remove interfering matrix components. <sup>[7]</sup> Adjust the chromatography to separate the analyte from the suppression zone.
Incorrect MS/MS Transition	Infuse a standard solution of (+)-Norcisapride to determine the optimal precursor and product ions (MRM transition) and collision energy.

### Problem 2: Poor Enantiomeric Resolution in Chiral Separation

Possible Cause	Suggested Solution
Inappropriate Chiral Stationary Phase (CSP)	Screen different types of CSPs (e.g., polysaccharide-based, macrocyclic glycopeptide-based) to find one that provides selectivity for (+)-Norcisapride enantiomers.
Mobile Phase Composition	For normal-phase separations, optimize the alcohol modifier concentration. For reversed-phase, adjust the organic modifier and pH. <sup>[3]</sup> For polar ionic mode, vary the acid/base ratio. <sup>[6]</sup>
Temperature Effects	Systematically evaluate the effect of column temperature on resolution, as it can have a significant impact on chiral recognition. <sup>[3]</sup>

## Quantitative Data Summary

The following tables provide typical parameters for the analytical methods discussed. Note that these are starting points and may require optimization for specific applications.

Table 1: HPLC Method Parameters for Norcisapride Analysis[2]

Parameter	Value
Column	Alltech Platinum EPS C8, 5 µm, 150 x 4.6 mm
Mobile Phase	Methanol: 0.02M Sodium Dihydrogen Phosphate (45:55, v/v) containing Triethylamine (1 g/L), pH 7.0
Flow Rate	1.3 mL/min
Detection	Fluorescence (Excitation: 295 nm, Emission: 300 nm)
Linearity Range	50 - 2000 ng/mL in human urine
Mean Recovery	71.2%

Table 2: Representative LC-MS/MS Parameters for Basic Drug Analysis

Parameter	Typical Value/Condition
Ionization Mode	ESI Positive
Scan Type	Multiple Reaction Monitoring (MRM)
Mobile Phase Additives	0.1% Formic Acid or 5-10 mM Ammonium Formate
Collision Gas	Argon
Precursor Ion (Q1)	[M+H] <sup>+</sup> of (+)-Norcisapride
Product Ion (Q3)	To be determined by infusion of a standard
Collision Energy (CE)	To be optimized for the specific MRM transition

## Experimental Protocols

### HPLC Analysis of Norcisapride in Urine[2]

- Sample Preparation (Liquid-Liquid Extraction):
  - To 0.5 mL of urine, add an internal standard.
  - Add a suitable buffer to adjust the pH.
  - Extract with a mixture of toluene and isoamyl alcohol (95:5, v/v).
  - Vortex and centrifuge the sample.
  - Transfer the organic layer to a clean tube and evaporate to dryness under a stream of nitrogen.
  - Reconstitute the residue in the mobile phase.
- Chromatographic Conditions:
  - Inject the reconstituted sample onto the HPLC system.
  - Use the parameters outlined in Table 1.

### Forced Degradation Study (General Protocol)[12][13][14][15][16]

To develop a stability-indicating method, forced degradation studies are performed to generate potential degradation products.

- Acid Hydrolysis: Treat the drug substance with 0.1 M HCl at room temperature and elevated temperature (e.g., 60 °C).
- Base Hydrolysis: Treat the drug substance with 0.1 M NaOH at room temperature and elevated temperature.
- Oxidative Degradation: Treat the drug substance with a solution of hydrogen peroxide (e.g., 3%) at room temperature.

- Thermal Degradation: Expose the solid drug substance to dry heat (e.g., 80 °C).
- Photodegradation: Expose the drug substance (solid and in solution) to UV and visible light.

Samples are collected at various time points and analyzed by a suitable analytical method (e.g., HPLC, LC-MS) to separate and identify any degradation products.

## Visualizations

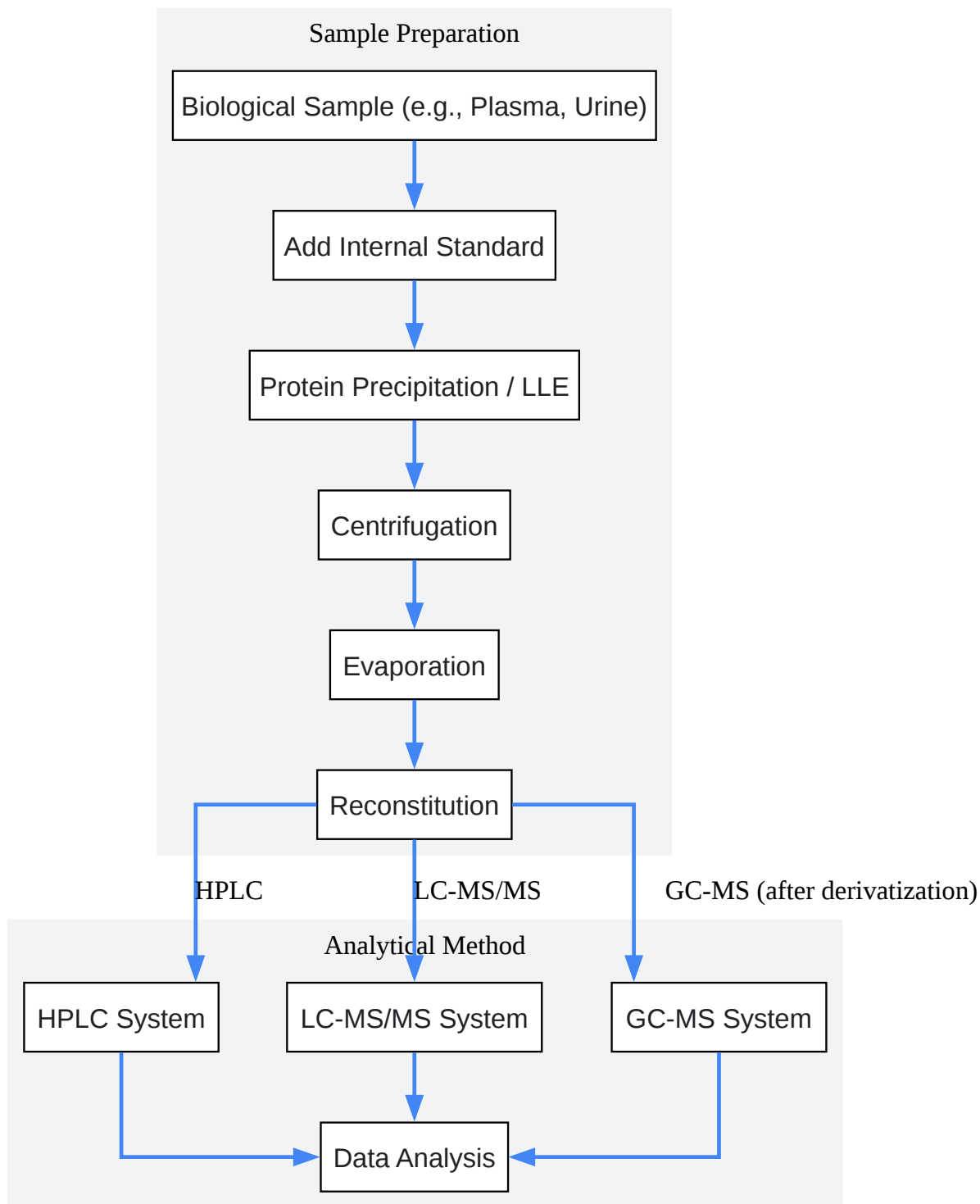

[Click to download full resolution via product page](#)

Caption: A generalized experimental workflow for the analysis of **(+)-Norcisapride** in biological matrices.

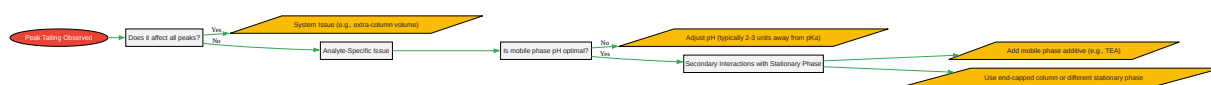

[Click to download full resolution via product page](#)

Caption: A decision tree for troubleshooting peak tailing in HPLC analysis.

### Need Custom Synthesis?

BenchChem offers custom synthesis for rare earth carbides and specific isotopic labeling.

Email: [info@benchchem.com](mailto:info@benchchem.com) or [Request Quote Online](#).

## References

- 1. Identification of a biliary metabolite of cisapride - PubMed [[pubmed.ncbi.nlm.nih.gov](https://pubmed.ncbi.nlm.nih.gov)]
- 2. [rsc.org](https://www.rsc.org) [[rsc.org](https://www.rsc.org)]
- 3. [benchchem.com](https://www.benchchem.com) [[benchchem.com](https://www.benchchem.com)]
- 4. Mass spectrometry detection of basic drugs in fast chiral analyses with vancomycin stationary phases - PMC [[pubmed.ncbi.nlm.nih.gov](https://pubmed.ncbi.nlm.nih.gov)]
- 5. [researchgate.net](https://www.researchgate.net) [[researchgate.net](https://www.researchgate.net)]
- 6. Chiral Chromatography Frequently Asked Questions [[sigmaaldrich.com](https://www.sigmaaldrich.com)]
- 7. [benchchem.com](https://www.benchchem.com) [[benchchem.com](https://www.benchchem.com)]
- 8. [jfda-online.com](https://www.jfda-online.com) [[jfda-online.com](https://www.jfda-online.com)]
- 9. The Use of Derivatization Reagents for Gas Chromatography (GC) [[sigmaaldrich.com](https://www.sigmaaldrich.com)]

- [10. Considerations to properly assess drug stability within biological samples - Anapharm \[anapharmbioanalytics.com\]](#)
- [11. researchgate.net \[researchgate.net\]](#)
- To cite this document: BenchChem. [Technical Support Center: (+)-Norcisapride Analytical Methods]. BenchChem, [2026]. [Online PDF]. Available at: [\[https://www.benchchem.com/product/b1209443/docs#technical-support-center-norcisapride-analytical-methods\]](https://www.benchchem.com/product/b1209443/docs#technical-support-center-norcisapride-analytical-methods)

---

### Disclaimer & Data Validity:

The information provided in this document is for Research Use Only (RUO) and is strictly not intended for diagnostic or therapeutic procedures. While BenchChem strives to provide accurate protocols, we make no warranties, express or implied, regarding the fitness of this product for every specific experimental setup.

**Technical Support:** The protocols provided are for reference purposes. Unsure if this reagent suits your experiment?

**Need Industrial/Bulk Grade?** [Request Custom Synthesis Quote](#)

## BenchChem

Our mission is to be the trusted global source of essential and advanced chemicals, empowering scientists and researchers to drive progress in science and industry.

### Contact

Address: 3281 E Guasti Rd  
Ontario, CA 91761, United States  
Phone: (601) 213-4426  
Email: [info@benchchem.com](mailto:info@benchchem.com)

[Contact our Ph.D. Support Team for a compatibility check](#)

