

Atherosperminine: A Technical Guide to its Known Pharmacological Effects

Author: BenchChem Technical Support Team. **Date:** December 2025

Compound of Interest

Compound Name: *Atherosperminine*

Cat. No.: *B1209876*

[Get Quote](#)

For Researchers, Scientists, and Drug Development Professionals

Abstract

Atherosperminine, a phenanthrene alkaloid derived from the Hofmann degradation of (-)-nuciferine, has demonstrated notable psychopharmacological activity. Early studies have characterized it as a compound with effects consistent with dopamine receptor stimulation. This technical guide provides a comprehensive overview of the currently known pharmacological effects of **Atherosperminine**, with a focus on its central nervous system activity. Due to a scarcity of recent research, this document primarily synthesizes findings from foundational studies. While qualitative effects are described, a significant gap exists in the public domain regarding quantitative pharmacological data and detailed mechanistic pathways. This guide aims to consolidate the existing knowledge, present relevant experimental methodologies, and identify key areas for future research and development.

Introduction

Atherosperminine is a derivative of the aporphine alkaloid nuciferine, found in plants of the *Nymphaea* (water lily) and *Nelumbo* (lotus) genera. Unlike its precursor, which exhibits properties associated with dopamine receptor blockade, **Atherosperminine** displays a pharmacological profile indicative of dopamine receptor agonism or stimulation[1]. This divergence in activity, despite their structural relationship, makes **Atherosperminine** a compound of interest for neuropharmacological research. This document serves as a technical

resource, summarizing the established pharmacological effects and providing detailed experimental context for the scientific community.

Pharmacological Effects

The primary pharmacological effects of **Atherosperminine** are centered on the central nervous system and are consistent with the stimulation of dopaminergic pathways.

Dopaminergic Activity

Atherosperminine's pharmacological profile is predominantly characterized by its effects on the dopamine system. It is suggested to act as a dopamine receptor stimulant[1]. The observed in vivo effects strongly support this classification.

- **Induction of Stereotyped Behavior:** Administration of **Atherosperminine** has been shown to induce stereotypy, a behavior characterized by repetitive, unvarying actions. This is a classic indicator of enhanced dopaminergic neurotransmission, particularly through the activation of postsynaptic dopamine receptors in the striatum.
- **Increased Spontaneous Motor Activity:** The compound leads to an increase in spontaneous motor activity, another hallmark of central dopamine system stimulation[1].
- **Reversal of Haloperidol-Induced Catalepsy:** **Atherosperminine** effectively reverses the catalepsy induced by the typical antipsychotic haloperidol, a potent dopamine D2 receptor antagonist. This further solidifies its role as a functional dopamine agonist[1].
- **Potentiation of Anticonvulsant Activity:** It has been reported to potentiate the anticonvulsant action of diphenylhydantoin[1].

Other Reported Effects

- **Inhibition of Morphine Analgesia:** **Atherosperminine** has been observed to inhibit the analgesic effects of morphine.

Quantitative Pharmacological Data

A thorough review of the available scientific literature reveals a significant lack of quantitative data for **Atherosperminine**. Parameters such as receptor binding affinities (K_i), in vitro

potencies (IC₅₀, EC₅₀), and in vivo dose-response relationships for its primary pharmacological effects have not been publicly reported. The following tables are provided as illustrative examples of how such data would be presented and should not be interpreted as experimental results.

Table 1: Illustrative Receptor Binding Affinity Profile for **Atherosperminine**

Receptor Subtype	Ligand	Ki (nM)	Assay Type	Source
Dopamine D1	[3H]-SCH23390	Data Not Available	Radioligand Binding	-
Dopamine D2	[3H]-Spiperone	Data Not Available	Radioligand Binding	-

Table 2: Illustrative In Vivo Dose-Response Data for **Atherosperminine**

Pharmacologic Effect	Animal Model	Route of Administration	ED50 (mg/kg)	Source
Induction of Stereotypy	Mouse	Intraperitoneal	Data Not Available	-
Reversal of Haloperidol-Induced Catalepsy	Rat	Intraperitoneal	Data Not Available	-

Postulated Signaling Pathway

Based on its functional profile as a dopamine receptor stimulant, it is hypothesized that **Atherosperminine**'s effects are mediated through the activation of dopamine receptors and their downstream signaling cascades. Activation of D1-like dopamine receptors typically leads to the stimulation of adenylyl cyclase, resulting in an increase in intracellular cyclic AMP (cAMP) levels and subsequent activation of Protein Kinase A (PKA). PKA can then

phosphorylate various downstream targets, including the protein phosphatase inhibitor DARPP-32, leading to the modulation of neuronal excitability and gene expression.

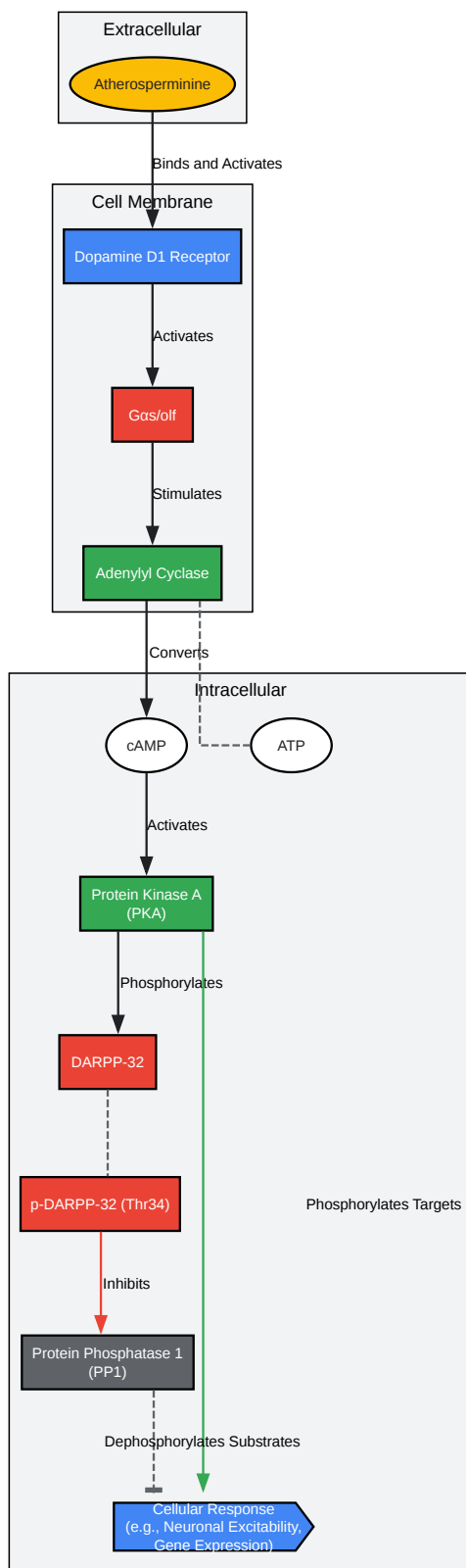

[Click to download full resolution via product page](#)

Caption: Postulated signaling pathway for **Atherosperminine** via D1 receptor activation.

Experimental Protocols

The following are generalized protocols for key in vivo assays used to characterize the dopaminergic effects of compounds like **Atherosperminine**. These should be adapted and optimized for specific experimental conditions.

Induction of Stereotyped Behavior in Mice

This protocol outlines a typical procedure for observing and scoring stereotyped behavior.

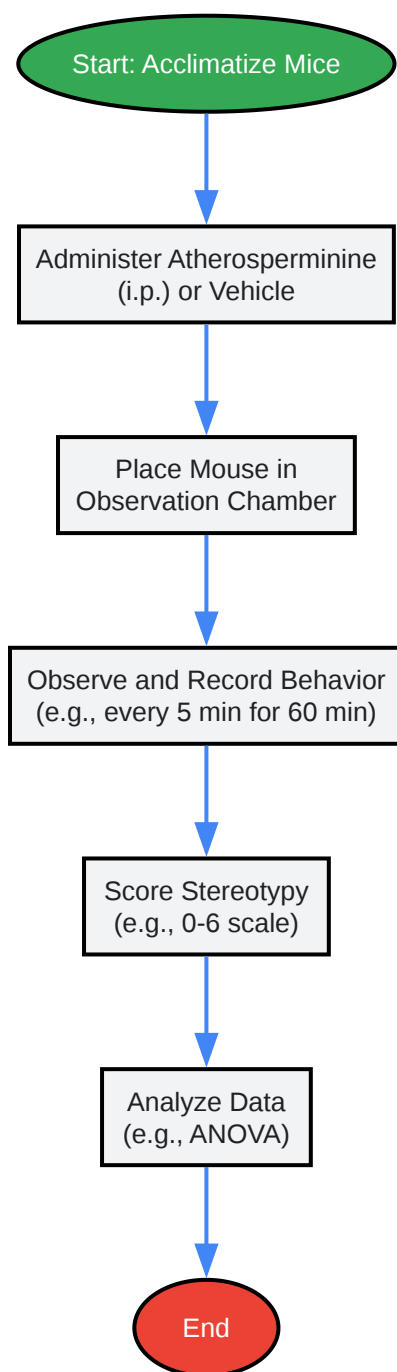

[Click to download full resolution via product page](#)

Caption: Experimental workflow for stereotypy assessment in mice.

Methodology:

- Animals: Male Swiss mice (20-25 g) are housed in a temperature-controlled environment with a 12-hour light/dark cycle and ad libitum access to food and water.

- **Acclimatization:** Mice are acclimatized to the experimental room for at least 1 hour before testing.
- **Drug Administration:** **Atherosperminine** is dissolved in a suitable vehicle (e.g., saline with a small amount of Tween 80) and administered intraperitoneally (i.p.) at various doses. A control group receives the vehicle only.
- **Observation:** Immediately after injection, each mouse is placed individually into a transparent observation cage.
- **Scoring:** The presence and intensity of stereotyped behaviors (e.g., sniffing, gnawing, head weaving) are scored by a trained observer blinded to the treatment groups at regular intervals (e.g., every 5 minutes for 60 minutes). A common scoring scale ranges from 0 (asleep or stationary) to 6 (continuous gnawing or licking).
- **Data Analysis:** The scores are analyzed to determine the dose-dependent effect of **Atherosperminine** on stereotyped behavior.

Reversal of Haloperidol-Induced Catalepsy in Rats

This protocol describes the bar test, a standard method for assessing catalepsy.

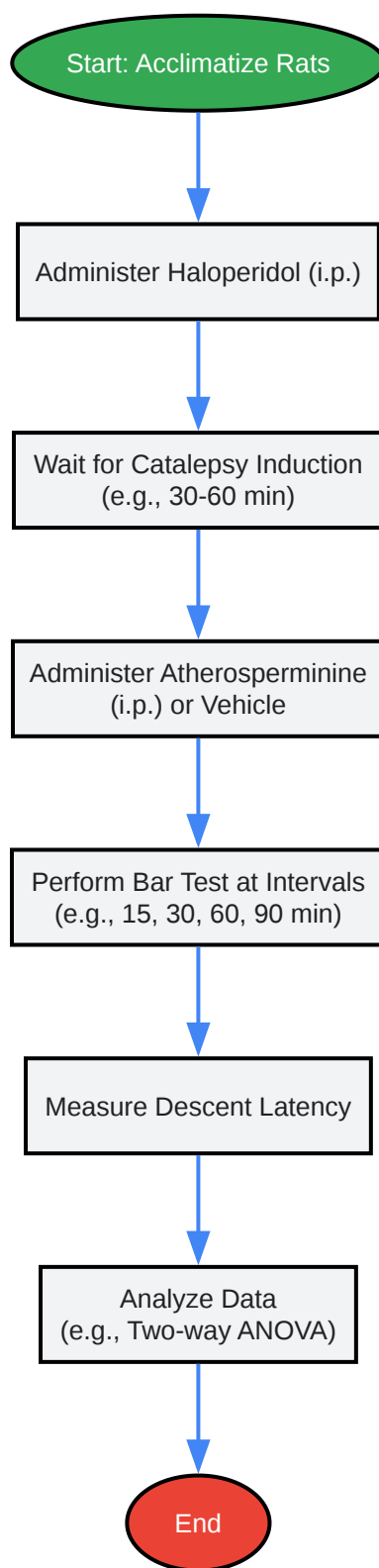

[Click to download full resolution via product page](#)

Caption: Experimental workflow for catalepsy reversal assay in rats.

Methodology:

- Animals: Male Wistar rats (150-200 g) are used.
- Induction of Catalepsy: Catalepsy is induced by the administration of haloperidol (e.g., 1-2 mg/kg, i.p.).
- Drug Administration: After a set period to allow for the development of catalepsy (e.g., 30-60 minutes), different doses of **Atherosperminine** or vehicle are administered.
- Bar Test: At various time points post-**Atherosperminine** administration (e.g., 15, 30, 60, 90 minutes), the rat's forepaws are gently placed on a horizontal bar raised a specific height (e.g., 9 cm) from the surface.
- Measurement: The time taken for the rat to remove both forepaws from the bar (descent latency) is recorded. A cut-off time (e.g., 180 seconds) is typically used.
- Data Analysis: The descent latencies are analyzed to assess the ability of **Atherosperminine** to reverse haloperidol-induced catalepsy in a dose- and time-dependent manner.

Toxicological Profile

There is a lack of publicly available data on the toxicological profile of **Atherosperminine**, including acute toxicity studies (e.g., LD50) and chronic toxicity assessments. This represents a critical knowledge gap for any further development of this compound.

Table 3: Illustrative Toxicological Data for **Atherosperminine**

Parameter	Animal Model	Route of Administration	Value	Source
LD50	Mouse	Intraperitoneal	Data Not Available	-
LD50	Rat	Oral	Data Not Available	-

Cardiovascular Effects

The effects of **Atherosperminine** on the cardiovascular system, including its impact on blood pressure and heart rate, have not been reported in the available literature. Given the potential for dopaminergic compounds to influence cardiovascular function, this is an important area for future investigation.

Conclusion and Future Directions

Atherosperminine is a pharmacologically active compound with a clear profile of a central dopamine system stimulant. The existing, albeit dated, research provides a solid foundation for its qualitative effects. However, for **Atherosperminine** to be considered a viable lead compound for drug development, a significant amount of further research is required. Key areas for future investigation include:

- **Quantitative Pharmacological Characterization:** Determination of binding affinities (K_i) at dopamine receptor subtypes (D1, D2, D3, etc.) and functional potencies (EC_{50}/IC_{50}) are essential.
- **Dose-Response Studies:** Comprehensive in vivo dose-response studies for its effects on stereotypy, motor activity, and catalepsy reversal are needed.
- **Mechanism of Action:** Elucidation of the specific downstream signaling pathways modulated by **Atherosperminine** is crucial. This includes investigating its effects on adenylyl cyclase activity and cAMP production in relevant neuronal populations.
- **Toxicology:** A thorough toxicological evaluation, including acute and repeated-dose toxicity studies, is necessary to establish a safety profile.
- **Pharmacokinetics:** Understanding the absorption, distribution, metabolism, and excretion (ADME) properties of **Atherosperminine** is critical for determining its drug-like potential.
- **Cardiovascular Safety:** Assessment of its effects on cardiovascular parameters is a prerequisite for any potential clinical development.

In conclusion, while **Atherosperminine** presents an interesting pharmacological profile, the current lack of in-depth, quantitative data limits its immediate translational potential. The

research community is encouraged to revisit this compound with modern pharmacological and molecular biology techniques to fully elucidate its therapeutic promise.

Need Custom Synthesis?

BenchChem offers custom synthesis for rare earth carbides and specific isotopic labeling.

Email: info@benchchem.com or [Request Quote Online](#).

References

- 1. Psychopharmacological studies on (–)-nuciferine and its Hofmann degradation product atherosperminine - PubMed [pubmed.ncbi.nlm.nih.gov]
- To cite this document: BenchChem. [Atherosperminine: A Technical Guide to its Known Pharmacological Effects]. BenchChem, [2025]. [Online PDF]. Available at: [https://www.benchchem.com/product/b1209876#known-pharmacological-effects-of-atherosperminine]

Disclaimer & Data Validity:

The information provided in this document is for Research Use Only (RUO) and is strictly not intended for diagnostic or therapeutic procedures. While BenchChem strives to provide accurate protocols, we make no warranties, express or implied, regarding the fitness of this product for every specific experimental setup.

Technical Support: The protocols provided are for reference purposes. Unsure if this reagent suits your experiment? [[Contact our Ph.D. Support Team for a compatibility check](#)]

Need Industrial/Bulk Grade? [Request Custom Synthesis Quote](#)

BenchChem

Our mission is to be the trusted global source of essential and advanced chemicals, empowering scientists and researchers to drive progress in science and industry.

Contact

Address: 3281 E Guasti Rd

Ontario, CA 91761, United States

Phone: (601) 213-4426

Email: info@benchchem.com