

Application Notes and Protocols for Emd 53998 in Isolated Heart Preparations

Author: BenchChem Technical Support Team. **Date:** May 2026

Compound of Interest

Compound Name:	Emd 53998
CAS No.:	120223-04-3
Cat. No.:	B1209479

[Get Quote](#)

For Researchers, Scientists, and Drug Development Professionals

Authored by a Senior Application Scientist

These application notes provide a comprehensive guide for utilizing **Emd 53998**, a potent inotropic agent, in isolated heart preparations. This document outlines the compound's mechanism of action, provides detailed protocols for its application in Langendorff-perfused hearts, and offers insights into expected outcomes and data interpretation.

Introduction to Emd 53998: A Dual-Action Inotrope

Emd 53998 is a thiadiazinone derivative that enhances cardiac contractility through a dual mechanism of action.^{[1][2]} It functions as both a myofilament calcium sensitizer and a phosphodiesterase III (PDE III) inhibitor.^{[1][2]} This dual action offers a unique pharmacological profile, leading to increased force of contraction with potentially greater energy efficiency compared to traditional inotropes that solely increase intracellular calcium levels.^[3]

- **Calcium Sensitization:** **Emd 53998** directly interacts with the contractile proteins, increasing their sensitivity to existing intracellular calcium levels.^{[2][3][4]} This leads to a more forceful

contraction for a given calcium concentration. Studies on skinned cardiac fibers have demonstrated a leftward shift in the force-calcium relationship upon application of **Emd 53998**.^[2]

- Phosphodiesterase III (PDE III) Inhibition: By inhibiting PDE III, **Emd 53998** prevents the breakdown of cyclic adenosine monophosphate (cAMP).^{[1][2]} Elevated cAMP levels contribute to increased intracellular calcium, further augmenting contractility.

The racemic mixture of **Emd 53998** possesses both activities, with its optical isomers showing a separation of these effects. The (+)-enantiomer, EMD 57033, is primarily responsible for the calcium-sensitizing effect, while the (-)-enantiomer exhibits PDE III inhibitory properties.^{[5][6]}

The Langendorff Isolated Heart Preparation: A Robust Ex Vivo Model

The Langendorff apparatus provides a reliable method for studying the direct effects of pharmacological agents on the heart, independent of systemic neural and hormonal influences.^{[7][8]} In this preparation, the heart is retrogradely perfused through the aorta with an oxygenated physiological salt solution, which maintains its viability and contractile function for several hours.^[8] This system allows for precise control over the composition of the perfusate and the administration of test compounds like **Emd 53998**.

Experimental Protocols

Preparation of the Langendorff Apparatus and Perfusion Buffer

A standard Langendorff system is required, equipped with a water-jacketed reservoir and tubing to maintain the perfusate at 37°C, a perfusion pump or a gravity-fed system to ensure constant flow or pressure, and a bubble trap.^[9]

Perfusion Buffer (Krebs-Henseleit Solution):

Component	Concentration (mM)
NaCl	118.0
KCl	4.7
CaCl ₂	2.5
MgSO ₄	1.2
KH ₂ PO ₄	1.2
NaHCO ₃	25.0
Glucose	11.0

- The solution should be freshly prepared with reagent-grade water and continuously gassed with 95% O₂ / 5% CO₂ to maintain a pH of 7.4.[10]

Heart Isolation and Cannulation (Rodent Model)

This protocol is a general guideline and should be adapted based on the specific animal model and institutional animal care and use committee (IACUC) guidelines.

- **Anesthesia and Heparinization:** Anesthetize the animal (e.g., rat, guinea pig) with an appropriate anesthetic. Administer heparin (e.g., 500 IU/kg, intraperitoneally) to prevent blood clotting.
- **Thoracotomy and Heart Excision:** Perform a thoracotomy to expose the heart. Rapidly excise the heart and immediately place it in ice-cold Krebs-Henseleit solution to arrest contractions and preserve myocardial integrity.
- **Aortic Cannulation:** Identify the aorta and carefully mount it onto the aortic cannula of the Langendorff apparatus, ensuring no air bubbles are introduced into the coronary circulation. Secure the aorta with a suture.
- **Initiation of Perfusion:** Immediately begin retrograde perfusion with the oxygenated Krebs-Henseleit solution at a constant pressure (e.g., 60-80 mmHg for a rat heart) or constant flow (e.g., 10-15 mL/min for a rat heart).

Stabilization and Baseline Recording

Allow the heart to stabilize for a period of 20-30 minutes. During this time, the heart should resume a regular, spontaneous rhythm. Key functional parameters should be continuously monitored and recorded to establish a stable baseline before drug administration. These parameters include:

- Left Ventricular Developed Pressure (LVDP): Measured by inserting a fluid-filled balloon connected to a pressure transducer into the left ventricle.
- Heart Rate (HR): Derived from the LVDP signal or an electrocardiogram (ECG).
- Coronary Flow (CF): Measured by collecting the coronary effluent.
- dP/dtmax and dP/dtmin: The maximum and minimum rates of pressure change, respectively, which are sensitive indices of contractility and relaxation.

Administration of Emd 53998

- Stock Solution Preparation: Prepare a stock solution of **Emd 53998** in a suitable solvent, such as dimethyl sulfoxide (DMSO). The final concentration of the solvent in the perfusate should be minimal (typically <0.1%) to avoid solvent-induced effects.
- Concentration-Response Curve: To determine the potency and efficacy of **Emd 53998**, a cumulative concentration-response curve is recommended. Start with a low concentration (e.g., 0.1 μM) and incrementally increase the concentration (e.g., 0.3, 1, 3, 10, 30, 100 μM) every 15-20 minutes, or until a stable response is achieved at each concentration.^[1]
- Method of Administration: **Emd 53998** should be added directly to the perfusion reservoir or infused into the perfusion line just before it enters the heart to ensure accurate final concentrations.

Data Acquisition and Analysis

A data acquisition system should be used to continuously record the physiological parameters. The data should be analyzed to quantify the changes in cardiac function in response to **Emd 53998**. The EC₅₀ (half-maximal effective concentration) can be calculated from the concentration-response curve to determine the potency of the compound.

Expected Outcomes and Interpretation

Based on its known mechanism of action, **Emd 53998** is expected to elicit the following dose-dependent effects in an isolated heart preparation:

Parameter	Expected Response	Rationale
LVDP	Increase	Increased myofilament Ca ²⁺ sensitivity and intracellular cAMP lead to a more forceful contraction.[1][2][3]
dP/dtmax	Increase	Reflects the enhanced rate of pressure development during systole due to increased contractility.
Heart Rate	Variable/Slight Increase	PDE III inhibition can lead to a modest increase in heart rate.
Coronary Flow	Potential Increase	Vasodilatory effects may be observed due to PDE III inhibition.

Self-Validating System: To ensure the integrity of the preparation and the specificity of the observed effects, the following controls should be included:

- Vehicle Control: Perfuse a separate heart with the vehicle (e.g., DMSO) at the same concentrations used for **Emd 53998** to rule out any solvent effects.
- Time Control: Perfuse a heart with Krebs-Henseleit solution alone for the same duration as the drug experiment to account for any time-dependent changes in cardiac function.

Visualizing the Mechanism and Workflow Signaling Pathway of Emd 53998

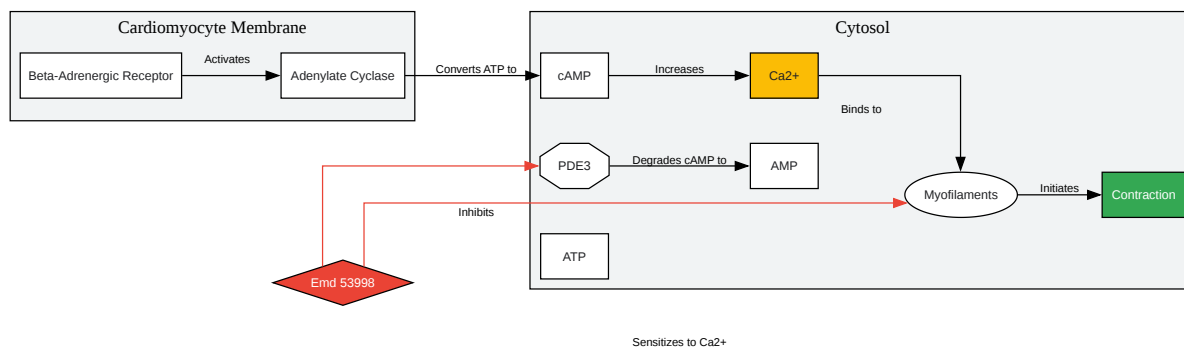

[Click to download full resolution via product page](#)

Caption: Dual mechanism of **Emd 53998** in cardiomyocytes.

Experimental Workflow for **Emd 53998** in Langendorff Preparation

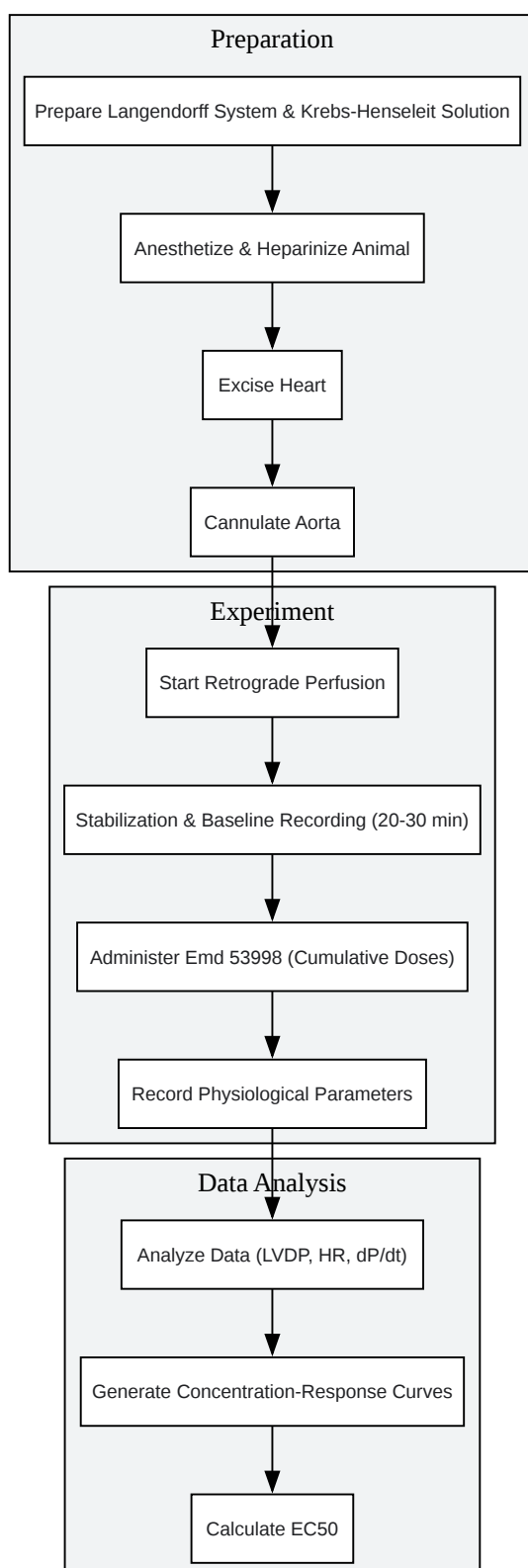

[Click to download full resolution via product page](#)

Caption: Step-by-step workflow for **Emd 53998** in isolated hearts.

Conclusion

Emd 53998 is a valuable pharmacological tool for studying cardiac contractility. Its dual mechanism of action provides a unique profile for enhancing cardiac function. The use of the Langendorff isolated heart preparation allows for a detailed and controlled investigation of its direct effects on the myocardium. The protocols and information provided herein serve as a comprehensive guide for researchers to effectively utilize **Emd 53998** in their cardiovascular research endeavors.

References

- Beier, N., et al. (1995). **EMD 53998** acts as Ca(2+)-sensitizer and phosphodiesterase III-inhibitor in human myocardium. *Basic Research in Cardiology*, 90(5), 365-371. [\[Link\]](#)
- Lee, J. A., & Allen, D. G. (1991). **EMD 53998** sensitizes the contractile proteins to calcium in intact ferret ventricular muscle. *Circulation Research*, 69(4), 927-936. [\[Link\]](#)
- Kraft, T., & Brenner, B. (1993). The positive inotropic calcium sensitizer **EMD 53998** antagonizes phosphate action on cross-bridges in cardiac skinned fibers. *Journal of Muscle Research and Cell Motility*, 14(5), 541-551. [\[Link\]](#)
- von der Leyen, H., et al. (1991). The novel cardiotoxic agent EMD 53 998 is a potent "calcium sensitizer". *Naunyn-Schmiedeberg's Archives of Pharmacology*, 344(1), 98-106. [\[Link\]](#)
- Marr, B. P., et al. (1992). Differential effects of the optical isomers of **EMD 53998** on contraction and cytoplasmic Ca²⁺ in isolated ferret cardiac muscle. *Circulation Research*, 71(1), 123-131. [\[Link\]](#)
- Bell, R. M., Mocanu, M. M., & Yellon, D. M. (2011). Retrograde heart perfusion: the Langendorff technique of isolated heart perfusion. *Journal of Molecular and Cellular Cardiology*, 50(6), 940-950. [\[Link\]](#)
- Langendorff, O. (1895). Untersuchungen am überlebenden Säugethierherzen. *Pflügers Archiv für die gesamte Physiologie des Menschen und der Tiere*, 61, 291-332. [\[Link\]](#)

- Hutchins, W., et al. (n.d.). High-throughput characterization of the resistance in response to and cardiac function during myocardial ischemia in normoxic an. PhysGen. [[Link](#)]
- ADInstruments. (n.d.). Langendorff Isolated Heart Perfusion Systems. [[Link](#)]
- Gambari, G., et al. (1993). Enantiomeric dissection of the effects of the inotropic agent, **EMD 53998**, in single cardiac myocytes. American Journal of Physiology-Heart and Circulatory Physiology, 264(3), H728-H735. [[Link](#)]
- Smith, A. M., et al. (1992). Differential effects of the optical isomers of **EMD 53998** on contraction and cytoplasmic Ca²⁺ in isolated ferret cardiac muscle. Circulation Research, 71(1), 123-131. [[Link](#)]

Need Custom Synthesis?

BenchChem offers custom synthesis for rare earth carbides and specific isotopic labeling.

Email: info@benchchem.com or [Request Quote Online](#).

Sources

- [1. EMD 53998 acts as Ca\(2+\)-sensitizer and phosphodiesterase III-inhibitor in human myocardium - PubMed \[pubmed.ncbi.nlm.nih.gov\]](#)
- [2. The novel cardiotoxic agent EMD 53 998 is a potent "calcium sensitizer" - PubMed \[pubmed.ncbi.nlm.nih.gov\]](#)
- [3. EMD 53998 sensitizes the contractile proteins to calcium in intact ferret ventricular muscle - PubMed \[pubmed.ncbi.nlm.nih.gov\]](#)
- [4. The positive inotropic calcium sensitizer EMD 53998 antagonizes phosphate action on cross-bridges in cardiac skinned fibers - PubMed \[pubmed.ncbi.nlm.nih.gov\]](#)
- [5. ahajournals.org \[ahajournals.org\]](#)
- [6. Differential effects of the optical isomers of EMD 53998 on contraction and cytoplasmic Ca²⁺ in isolated ferret cardiac muscle - PubMed \[pubmed.ncbi.nlm.nih.gov\]](#)
- [7. Retrograde heart perfusion: the Langendorff technique of isolated heart perfusion - PubMed \[pubmed.ncbi.nlm.nih.gov\]](#)
- [8. Langendorff heart - Wikipedia \[en.wikipedia.org\]](#)

- [9. adinstruments.com \[adinstruments.com\]](http://adstruments.com)
- [10. rgd.mcw.edu \[rgd.mcw.edu\]](http://rgd.mcw.edu)
- To cite this document: BenchChem. [Application Notes and Protocols for Emd 53998 in Isolated Heart Preparations]. BenchChem, [2026]. [Online PDF]. Available at: [<https://www.benchchem.com/product/b1209479/docs#application-notes-and-protocols-for-emd-53998-in-isolated-heart-preparations>]

Disclaimer & Data Validity:

The information provided in this document is for Research Use Only (RUO) and is strictly not intended for diagnostic or therapeutic procedures. While BenchChem strives to provide accurate protocols, we make no warranties, express or implied, regarding the fitness of this product for every specific experimental setup.

Technical Support: The protocols provided are for reference purposes. Unsure if this reagent suits your experiment?

Need Industrial/Bulk Grade? [Request Custom Synthesis Quote](#)

BenchChem

Our mission is to be the trusted global source of essential and advanced chemicals, empowering scientists and researchers to drive progress in science and industry.

Contact

Address: 3281 E Guasti Rd
Ontario, CA 91761, United States
Phone: (601) 213-4426
Email: info@benchchem.com

[Contact our Ph.D. Support Team for a compatibility check](#)