

# 2,3-dimercaptopropionic acid pKa values and ionization states

**Author:** BenchChem Technical Support Team. **Date:** April 2026

## Compound of Interest

Compound Name: 2,3-Dimercaptopropionic acid

CAS No.: 6220-25-3

Cat. No.: B1209159

[Get Quote](#)

## Part 1: Executive Summary & Chemical Identity

**2,3-Dimercaptopropionic acid** (DMPA) is a vicinal dithiol chelating agent structurally related to Dimercaprol (BAL) and 2,3-Dimercapto-1-propanesulfonic acid (DMPS). Unlike its analogs, DMPA possesses a terminal carboxylic acid moiety, imparting unique solubility and coordination properties. Its efficacy in heavy metal chelation (Hg, As, Pb) and radiopharmaceutical labeling (Re, Tc) is governed strictly by its ionization state.

This guide provides a definitive physicochemical profile of DMPA, focusing on its acid dissociation constants (pKa), speciation behavior, and the rigorous experimental protocols required to determine these values without oxidative interference.

Chemical Structure:

IUPAC Name: 2,3-disulfanylpropanoic acid Key Functional Groups:

- Carboxylic Acid (

)[1]

- Alpha-Thiol ( )  
at C2)
- Beta-Thiol ( )  
at C3)

## Part 2: Thermodynamic Constants & Ionization Profile

The ionization of DMPA occurs in three distinct steps. The carboxylic acid deprotonates first, followed by the two thiol groups. The proximity of the two thiols results in a significant difference between the first and second thiol pKa values due to Coulombic repulsion and statistical factors.

**Table 1: Dissociation Constants of DMPA (25°C, I = 0.1 M)**

Ionization Step	Group Assignment	pKa Value	Species Formed
pKa <sub>1</sub>	Carboxylic Acid ( )	3.30 – 3.60*	(Mono-anion)
pKa <sub>2</sub>	Thiol 1 (First )	8.62	(Di-anion)
pKa <sub>3</sub>	Thiol 2 (Second )	10.57	(Tri-anion)

\*Note: The carboxyl pKa is influenced by the inductive effect of the

-thiol group. While specific literature values vary slightly based on ionic strength, the range 3.3–3.6 is consistent with

-mercapto acid derivatives (e.g., thiolactic acid pKa = 3.67).

## Macroscopic vs. Microscopic Constants

For the thiol groups ( $pK_{a2}$  and  $pK_{a3}$ ), the values 8.62 and 10.57 are macroscopic constants.

- Micro-speciation: At pH values between 8.6 and 10.6, the negative charge is not localized solely on one sulfur atom. It is distributed between the C2 and C3 thiols.
- Interaction: The deprotonation of the first thiol creates a negative charge that destabilizes the remaining proton on the second thiol (raising its  $pK_a$ ) due to electrostatic repulsion. This is why  $pK_{a3}$  (10.57) is significantly higher than the  $pK_a$  of a typical isolated thiol (~8.5–9.0).

## Part 3: Speciation & Signaling Pathways[3]

Understanding the dominant species at physiological pH (7.4) is critical for drug development.

- pH < 3.0: Predominantly  
  
(Neutral). Poor metal binding.
- pH 4.0 – 7.0: Predominantly  
  
(Carboxylate anion). The thiols remain protonated. This species is water-soluble but requires deprotonation of sulfur for strong metal coordination.
- pH 7.4 (Physiological): Mixture of  
  
and  
  
. The onset of thiol deprotonation begins here, facilitating metal exchange with biological ligands (e.g., albumin, cysteine).
- pH > 11.0: Predominantly  
  
. Fully active chelator.

## Visualization: Ionization Pathway

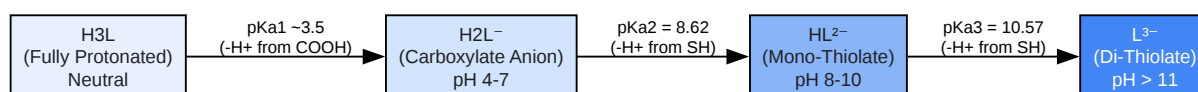

[Click to download full resolution via product page](#)

Caption: Stepwise deprotonation of **2,3-dimercaptopropionic acid**. The transition from  $\text{H}_2\text{L}^-$  to  $\text{HL}^{2-}$  is the critical step for biological metal chelation.

## Part 4: Experimental Methodologies

Determining the pKa of polyprotic thiols is technically demanding due to the rapid oxidation of thiols to disulfides in air. The following protocol ensures data integrity.

### Protocol: Inert Atmosphere Potentiometric Titration

Objective: Determine precise pKa values by measuring pH changes during titration with a strong base, strictly excluding oxygen.

Reagents & Equipment:

- Ligand: High-purity DMPA (>98%).
- Titrant: Carbonate-free NaOH (0.1 M), standardized against potassium hydrogen phthalate (KHP).
- Ionic Strength Adjuster: KCl or  $\text{NaClO}_4$  (0.1 M) to maintain constant activity coefficients.
- Inert Gas: High-purity Nitrogen ( ) or Argon ( ), pre-saturated with water vapor.
- Apparatus: Jacketed titration vessel (25°C), precision pH electrode (calibrated at pH 4.0, 7.0, 10.0).

Step-by-Step Workflow:

- System Preparation:
  - Fill the jacketed vessel with water from a thermostat set to  $25.0 \pm 0.1^\circ\text{C}$ .

- Purge the empty vessel and all reagent lines with  
  
for 15 minutes.
- Solution Preparation (In Situ):
  - Dissolve ~0.1 mmol of DMPA in 40 mL of degassed 0.1 M KCl solution inside the vessel under continuous  
  
flow.
  - Critical Control: Add a slight excess of HCl (0.01 M) initially to fully protonate the ligand (start pH < 2.5).
- Titration:
  - Titrate with 0.1 M NaOH using a micro-burette (increments of 0.01–0.05 mL).
  - Wait for electrode stability (<0.1 mV drift/min) before recording each point.
  - Continue titration until pH reaches ~12.0 (fully deprotonated).
- Data Analysis:
  - Plot pH vs. Volume of NaOH.[\[2\]](#)
  - Use the Bjerrum method (function) or non-linear least squares software (e.g., HYPERQUAD) to refine constants.
  - Self-Validation: The titration curve must show three inflection points (or two distinct regions if pKa2 and pKa3 overlap). If drift occurs, oxidation is likely; discard run.

## Visualization: Experimental Setup

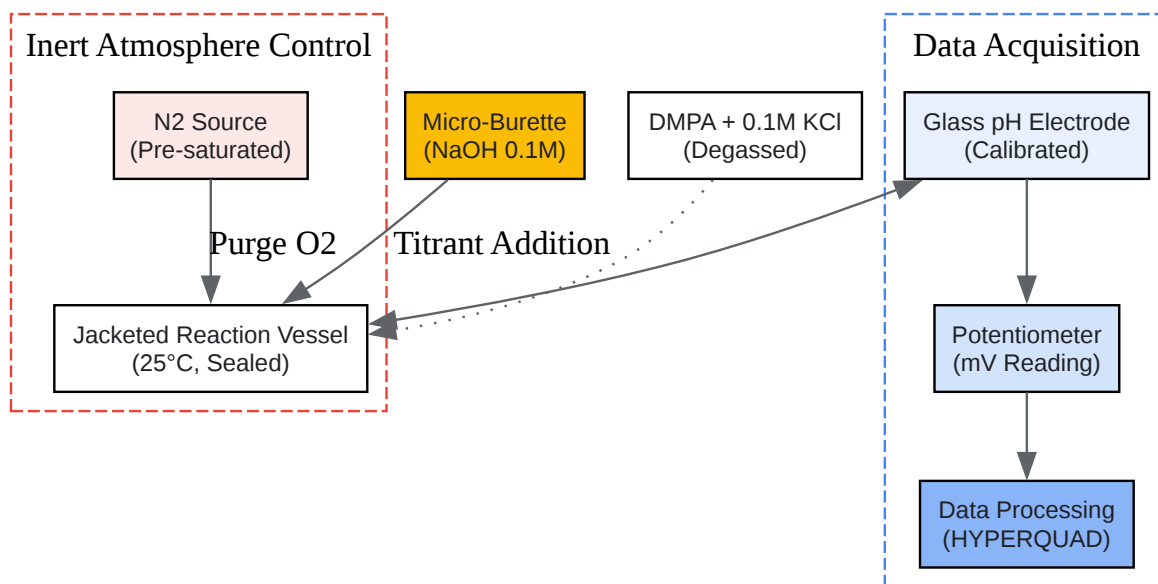

[Click to download full resolution via product page](#)

Caption: Schematic of the potentiometric titration setup required to prevent thiol oxidation during pKa determination.

## Part 5: Implications for Drug Development

- Chelation Stability: The stability constant ( $K_{st}$ ) of DMPA-Metal complexes is directly linked to the pKa.
  - Logic: A higher thiol pKa implies a stronger conjugate base (thiolate), which typically forms stronger bonds with soft metals ( $K_{st}$ ). However, it also means the ligand competes less effectively with protons at neutral pH.
  - Optimization: For physiological applications (pH 7.4), DMPA is effective because  $K_{st}$  (8.62) is close enough to neutral that a significant fraction of the mono-thiolate exists or is easily accessible.
- Formulation Stability:

- DMPA is susceptible to auto-oxidation to form disulfides (polymers or cyclic species).
- Requirement: Formulations must be maintained at pH < 4 (where the thiol is protonated and stable) or stored under inert gas.

## References

- IUPAC. (2023). Digitized pKa Dataset: 2,3-dimercaptopropanoic acid. IUPAC/Dissociation-Constants. Retrieved from [\[Link\]](#)
- PubChem. (2023). **2,3-Dimercaptopropionic acid** (CID 110807). National Library of Medicine. Retrieved from [\[Link\]](#)
- Canty, A. J., & Kishimoto, R. (1993). Influence of 2,3-dimercaptopropane-1-sulfonate (DMPS) and meso-2,3-dimercaptosuccinic acid (DMSA) on the renal disposition of mercury. Journal of Pharmacology and Experimental Therapeutics. Retrieved from [\[Link\]](#)
- Creative Bioarray. (2024). Protocol for Determining pKa Using Potentiometric Titration. Retrieved from [\[Link\]](#)

### Need Custom Synthesis?

BenchChem offers custom synthesis for rare earth carbides and specific isotopic labeling.

Email: [info@benchchem.com](mailto:info@benchchem.com) or [Request Quote Online](#).

## Sources

- [1. fileserver-az.core.ac.uk](https://fileserver-az.core.ac.uk) [[fileserver-az.core.ac.uk](https://fileserver-az.core.ac.uk)]
- [2. cdn2.f-cdn.com](https://cdn2.f-cdn.com) [[cdn2.f-cdn.com](https://cdn2.f-cdn.com)]
- To cite this document: BenchChem. [2,3-dimercaptopropionic acid pKa values and ionization states]. BenchChem, [2026]. [Online PDF]. Available at: [\[https://www.benchchem.com/product/b1209159/docs#2-3-dimercaptopropionic-acid-pka-values-and-ionization-states\]](https://www.benchchem.com/product/b1209159/docs#2-3-dimercaptopropionic-acid-pka-values-and-ionization-states)

### Disclaimer & Data Validity:

The information provided in this document is for Research Use Only (RUO) and is strictly not intended for diagnostic or therapeutic procedures. While BenchChem strives to provide accurate protocols, we make no warranties, express or implied, regarding the fitness of this product for every specific experimental setup.

**Technical Support:** The protocols provided are for reference purposes. Unsure if this reagent suits your experiment?

**Need Industrial/Bulk Grade?** [Request Custom Synthesis Quote](#)

## BenchChem

Our mission is to be the trusted global source of essential and advanced chemicals, empowering scientists and researchers to drive progress in science and industry.

### Contact

Address: 3281 E Guasti Rd  
Ontario, CA 91761, United States  
Phone: (601) 213-4426  
Email: [info@benchchem.com](mailto:info@benchchem.com)

[Contact our Ph.D. Support Team for a compatibility check](#)