

# Technical Support Center: YM-08 Experiments

**Author:** BenchChem Technical Support Team. **Date:** April 2026

## Compound of Interest

Compound Name: YM-08  
Cat. No.: B12086332

[Get Quote](#)

This technical support center provides troubleshooting guidance and frequently asked questions (FAQs) for researchers, scientists, and drug development professionals working with **YM-08**. The information is designed to address common problems encountered during experimental procedures.

## Frequently Asked Questions (FAQs)

Q1: What is the primary mechanism of action for **YM-08**?

A1: **YM-08** is an immunomodulatory drug (IMiD) that functions as a molecular glue. Its primary target is the Cereblon (CRBN) protein, which is a component of the CUL4-RBX1-DDB1-CRBN E3 ubiquitin ligase complex. By binding to CRBN, **YM-08** induces the ubiquitination and subsequent proteasomal degradation of specific neo-substrates, including the lymphoid transcription factors Ikaros (IKZF1) and Aiolos (IKZF3). The degradation of these transcription factors leads to both direct anti-myeloma effects and immunomodulatory activities, such as T-cell co-stimulation and enhancement of anti-tumor immune responses.

Q2: Which cell lines are recommended for initial **YM-08** screening?

A2: For initial screening of **YM-08**, it is recommended to use a panel of multiple myeloma cell lines with varying genetic backgrounds and sensitivities to other IMiDs. Commonly used cell

lines include RPMI-8226, U266, and MM.1S. It is advisable to test a range of concentrations to determine the half-maximal inhibitory concentration (IC50) for each cell line.

Q3: What are the expected immunomodulatory effects of **YM-08** in vitro?

A3: **YM-08** is expected to exhibit several immunomodulatory effects, including the stimulation of T-cell proliferation and the increased production of Th1-type cytokines such as Interleukin-2 (IL-2) and Interferon-gamma (IFN- $\gamma$ ).<sup>[1][2]</sup> Conversely, **YM-08** is anticipated to decrease the secretion of pro-inflammatory and immunosuppressive cytokines like Tumor Necrosis Factor-alpha (TNF- $\alpha$ ) and Interleukin-6 (IL-6).<sup>[1][2]</sup>

Q4: Can **YM-08** be used in combination with other therapeutic agents?

A4: Yes, based on its mechanism of action, **YM-08** has the potential for synergistic effects when combined with other anti-myeloma agents. For instance, its immunomodulatory properties may enhance the efficacy of monoclonal antibodies through antibody-dependent cellular cytotoxicity (ADCC). Combination with proteasome inhibitors or corticosteroids is also a potential therapeutic strategy, though dose optimization is crucial to avoid antagonistic effects on immune stimulation.

## Troubleshooting Guides

This section provides solutions to common problems encountered during key experiments with **YM-08**.

### Cell Viability (MTT/XTT) Assay

Problem	Potential Cause(s)	Recommended Solution(s)
High Background Absorbance	<ol style="list-style-type: none"> <li>1. Contamination of media or reagents.</li> <li>2. Phenol red in the medium interfering with absorbance readings.</li> <li>3. YM-08 directly reducing the MTT reagent.</li> </ol>	<ol style="list-style-type: none"> <li>1. Use sterile technique and fresh reagents.</li> <li>2. Use phenol red-free medium for the assay.</li> <li>3. Perform a cell-free control with YM-08 and MTT reagent to check for direct reduction. If positive, consider an alternative viability assay (e.g., CellTiter-Glo®).</li> </ol>
Low Signal or Poor Dynamic Range	<ol style="list-style-type: none"> <li>1. Suboptimal cell seeding density.</li> <li>2. Insufficient incubation time with MTT reagent.</li> <li>3. Cell metabolic activity is too low.</li> </ol>	<ol style="list-style-type: none"> <li>1. Optimize cell seeding density to ensure cells are in the logarithmic growth phase during the assay.</li> <li>2. Increase incubation time with MTT, monitoring for formazan crystal formation.</li> <li>3. Ensure cells are healthy and metabolically active before starting the experiment.</li> </ol>
Inconsistent Results Between Replicates	<ol style="list-style-type: none"> <li>1. Uneven cell seeding.</li> <li>2. Incomplete solubilization of formazan crystals.</li> <li>3. "Edge effect" in the microplate.</li> </ol>	<ol style="list-style-type: none"> <li>1. Ensure a homogenous cell suspension before and during seeding.</li> <li>2. After adding the solubilization buffer, mix thoroughly by pipetting or using a plate shaker.</li> <li>3. Avoid using the outer wells of the plate or fill them with sterile PBS to maintain humidity.</li> </ol>

## Apoptosis (Annexin V) Assay

Problem	Potential Cause(s)	Recommended Solution(s)
High Percentage of Apoptotic Cells in Negative Control	<ol style="list-style-type: none"> <li>1. Harsh cell handling during harvesting (e.g., over-trypsinization).</li> <li>2. Cells are overgrown or unhealthy.</li> <li>3. Spontaneous apoptosis in the cell line.</li> </ol>	<ol style="list-style-type: none"> <li>1. Use a gentle cell detachment method. Allow cells to recover for 30 minutes in culture medium after trypsinization before staining.</li> <li>2. Use cells from a culture in the logarithmic growth phase.</li> <li>3. Check the baseline apoptosis rate for your cell line and ensure it is within an acceptable range.</li> </ol>
Weak or No Annexin V Signal in Positive Control	<ol style="list-style-type: none"> <li>1. Ineffective apoptosis-inducing agent or insufficient treatment time.</li> <li>2. Loss of apoptotic cells during washing steps.</li> <li>3. Incorrect staining buffer (lacking calcium).</li> </ol>	<ol style="list-style-type: none"> <li>1. Confirm the efficacy of your positive control for apoptosis induction.</li> <li>2. Be gentle during washing and centrifugation steps.</li> <li>3. Ensure the binding buffer contains calcium, as Annexin V binding to phosphatidylserine is calcium-dependent.</li> </ol>
High PI/7-AAD Staining in All Samples	<ol style="list-style-type: none"> <li>1. Delayed analysis after staining, leading to secondary necrosis.</li> <li>2. Cell membrane damage from harsh handling.</li> <li>3. Freeze-thaw cycles of cells.</li> </ol>	<ol style="list-style-type: none"> <li>1. Analyze samples on the flow cytometer as soon as possible after staining.</li> <li>2. Handle cells gently throughout the protocol.</li> <li>3. Use freshly harvested cells for the assay.</li> </ol>

## Cytokine Release (Luminex/ELISA) Assay

Problem	Potential Cause(s)	Recommended Solution(s)
High Background Signal	1. Insufficient washing.2. Non-specific binding of antibodies.3. Contaminated reagents or samples.	1. Ensure all washing steps are performed thoroughly according to the protocol.2. Use a blocking buffer and ensure it is appropriate for your sample type.3. Use fresh, sterile reagents and handle samples appropriately to avoid contamination.
Low or No Signal Detected	1. Cytokine concentrations are below the limit of detection.2. Incorrect antibody pair or expired reagents.3. Suboptimal incubation times or temperatures.	1. Concentrate the cell culture supernatant or use a more sensitive assay kit.2. Verify the specificity and expiration date of all reagents.3. Adhere strictly to the recommended incubation parameters in the protocol.
High Variability Between Replicates	1. Pipetting errors.2. Inconsistent sample handling.3. Bubbles in the wells of the microplate.	1. Ensure accurate and consistent pipetting; calibrate pipettes regularly.2. Treat all samples and standards identically.3. Be careful to avoid introducing bubbles when adding reagents to the wells.

## Quantitative Data Summary

The following tables provide representative data from experiments with **YM-08** and other immunomodulatory drugs. This data is for illustrative purposes and may vary depending on the specific experimental conditions and cell lines used.

Table 1: **YM-08** IC50 Values in Multiple Myeloma Cell Lines (72h Treatment)

Cell Line	YM-08 IC50 ( $\mu\text{M}$ )	Lenalidomide IC50 ( $\mu\text{M}$ )[4]	Pomalidomide IC50 ( $\mu\text{M}$ )
RPMI-8226	1.5	~5.0 - 10.0[5]	~0.8
U266	8.2	>10.0	~2.5
MM.1S	0.9	~3.0[5]	~0.5
NCI-H929	0.5	~0.15 - 1.0[4]	~0.1

Table 2: Cytokine Secretion Profile in Co-culture of PBMCs and MM.1S Cells (48h Treatment)

Cytokine	Control (pg/mL)	YM-08 (1 $\mu\text{M}$ ) (pg/mL)	Fold Change
IFN- $\gamma$	150 $\pm$ 25	3300 $\pm$ 450	~22-fold increase
IL-2	80 $\pm$ 15	360 $\pm$ 50	~4.5-fold increase[2]
TNF- $\alpha$	1200 $\pm$ 200	480 $\pm$ 70	~0.4-fold change
IL-6	2500 $\pm$ 350	1750 $\pm$ 250	~0.7-fold change[2]

## Experimental Protocols

### Cell Viability MTT Assay Protocol

- Cell Seeding:** Seed multiple myeloma cells in a 96-well plate at a density of  $2 \times 10^4$  cells/well in 100  $\mu\text{L}$  of complete culture medium. Incubate for 24 hours at 37°C in a 5% CO<sub>2</sub> incubator.
- Compound Treatment:** Prepare serial dilutions of **YM-08** in culture medium. Add 100  $\mu\text{L}$  of the diluted compound to the respective wells. Include a vehicle control (e.g., 0.1% DMSO). Incubate for 72 hours.
- MTT Addition:** Add 20  $\mu\text{L}$  of MTT solution (5 mg/mL in PBS) to each well. Incubate for 4 hours at 37°C.

- **Formazan Solubilization:** Carefully remove 150  $\mu\text{L}$  of the medium from each well. Add 150  $\mu\text{L}$  of DMSO to each well to dissolve the formazan crystals.
- **Absorbance Measurement:** Shake the plate for 15 minutes on an orbital shaker to ensure complete dissolution. Measure the absorbance at 570 nm using a microplate reader.
- **Data Analysis:** Calculate the percentage of cell viability relative to the vehicle control and determine the IC50 value.

## Apoptosis Annexin V Staining Protocol

- **Cell Treatment:** Seed  $1 \times 10^6$  cells in a 6-well plate and treat with **YM-08** at the desired concentration for 48 hours. Include positive and negative controls.
- **Cell Harvesting:** Collect both adherent and suspension cells. Wash the cells twice with cold PBS.
- **Resuspension:** Resuspend the cell pellet in 1X Annexin V Binding Buffer at a concentration of  $1 \times 10^6$  cells/mL.
- **Staining:** Transfer 100  $\mu\text{L}$  of the cell suspension to a flow cytometry tube. Add 5  $\mu\text{L}$  of FITC-conjugated Annexin V and 5  $\mu\text{L}$  of Propidium Iodide (PI) solution.
- **Incubation:** Gently vortex the cells and incubate for 15 minutes at room temperature in the dark.
- **Analysis:** Add 400  $\mu\text{L}$  of 1X Binding Buffer to each tube and analyze by flow cytometry within one hour.

## Cytokine Release Luminex Assay Protocol

- **Sample Collection:** Co-culture peripheral blood mononuclear cells (PBMCs) with multiple myeloma cells in the presence of **YM-08** for 48 hours. Collect the culture supernatant and centrifuge to remove cellular debris.
- **Assay Preparation:** Prepare standards and samples according to the Luminex kit manufacturer's instructions.

- **Bead Incubation:** Add the antibody-coupled magnetic beads to each well of the 96-well plate, followed by the standards and samples. Incubate on a plate shaker for 2 hours at room temperature.
- **Washing:** Wash the plate twice with the provided wash buffer using a magnetic plate washer.
- **Detection Antibody Incubation:** Add the biotinylated detection antibody cocktail to each well and incubate for 1 hour at room temperature on a plate shaker.
- **Streptavidin-PE Incubation:** Wash the plate twice. Add Streptavidin-PE conjugate to each well and incubate for 30 minutes at room temperature on a plate shaker.
- **Data Acquisition:** Wash the plate three times. Resuspend the beads in sheath fluid and acquire data on a Luminex instrument.
- **Data Analysis:** Analyze the median fluorescence intensity (MFI) to determine the concentration of each cytokine based on the standard curve.

## Visualizations

### YM-08 Mechanism of Action

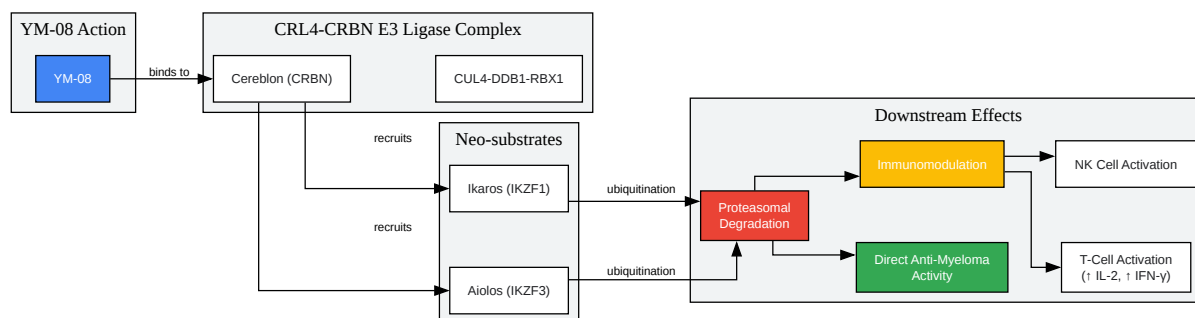

[Click to download full resolution via product page](#)

Caption: Signaling pathway of **YM-08**'s mechanism of action.

## Experimental Workflow for **YM-08** Evaluation

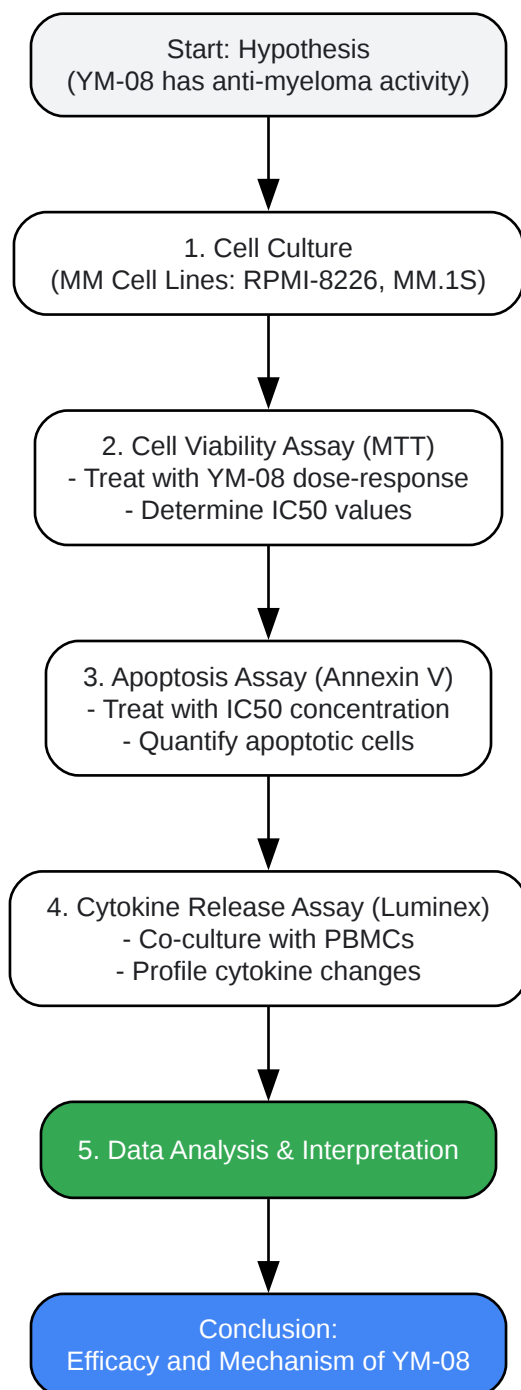

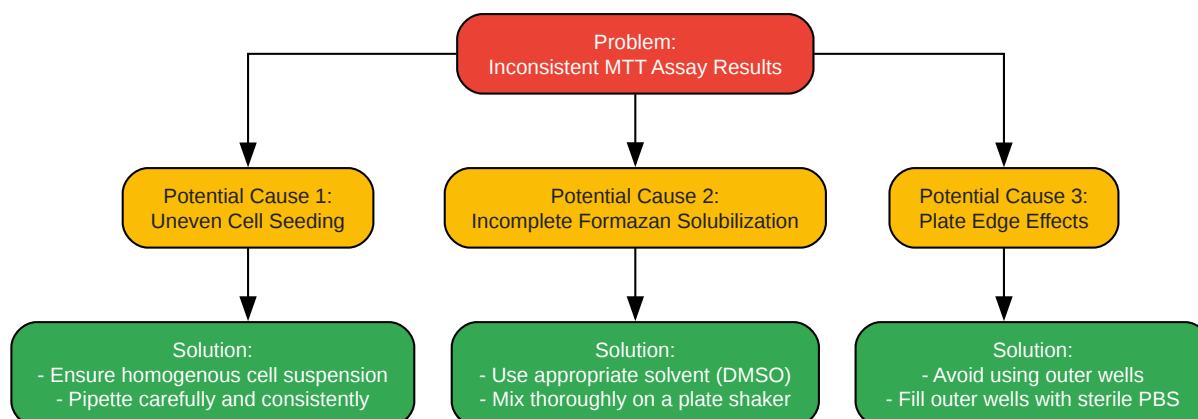

[Click to download full resolution via product page](#)

### Need Custom Synthesis?

BenchChem offers custom synthesis for rare earth carbides and specific isotopic labeling.

Email: [info@benchchem.com](mailto:info@benchchem.com) or [Request Quote Online](#).

## References

- 1. Immunomodulatory effects of lenalidomide and pomalidomide on interaction of tumor and bone marrow accessory cells in multiple myeloma - PMC [[pmc.ncbi.nlm.nih.gov](https://pubmed.ncbi.nlm.nih.gov/)]
- 2. [ashpublications.org](https://ashpublications.org) [[ashpublications.org](https://ashpublications.org)]
- 3. Tumor necrosis factor is a survival and proliferation factor for human myeloma cells - PMC [[pmc.ncbi.nlm.nih.gov](https://pubmed.ncbi.nlm.nih.gov/)]
- 4. Paradoxical effect of lenalidomide on cytokine/growth factor profiles in multiple myeloma - PMC [[pmc.ncbi.nlm.nih.gov](https://pubmed.ncbi.nlm.nih.gov/)]
- 5. [researchgate.net](https://www.researchgate.net) [[researchgate.net](https://www.researchgate.net)]
- To cite this document: BenchChem. [Technical Support Center: YM-08 Experiments]. BenchChem, [2026]. [Online PDF]. Available at: [<https://www.benchchem.com/product/b12086332/docs#technical-support-center-ym-08-experiments>]

**Disclaimer & Data Validity:**

The information provided in this document is for Research Use Only (RUO) and is strictly not intended for diagnostic or therapeutic procedures. While BenchChem strives to provide accurate protocols, we make no warranties, express or implied, regarding the fitness of this product for every specific experimental setup.

**Technical Support:** The protocols provided are for reference purposes. Unsure if this reagent suits your experiment?

**Need Industrial/Bulk Grade?** [Request Custom Synthesis Quote](#)

## BenchChem

Our mission is to be the trusted global source of essential and advanced chemicals, empowering scientists and researchers to drive progress in science and industry.

### Contact

Address: 3281 E Guasti Rd  
Ontario, CA 91761, United States  
Phone: (601) 213-4426  
Email: [info@benchchem.com](mailto:info@benchchem.com)

[Contact our Ph.D. Support Team for a compatibility check](#)