

Technical Support Center: Improving the Bioavailability of YM-08

Author: BenchChem Technical Support Team. **Date:** April 2026

Compound of Interest

Compound Name: YM-08
Cat. No.: B12086332

[Get Quote](#)

This technical support center provides researchers, scientists, and drug development professionals with a comprehensive guide to understanding and improving the bioavailability of **YM-08**, a blood-brain barrier permeable inhibitor of Heat Shock Protein 70 (Hsp70) and SIRT2. This guide offers troubleshooting advice, frequently asked questions, detailed experimental protocols, and data-driven insights to facilitate your research and development efforts.

Frequently Asked Questions (FAQs)

Q1: What is **YM-08** and what are its key properties?

YM-08 is a neutral analog of the Hsp70 inhibitor MKT-077, specifically designed for improved blood-brain barrier (BBB) penetration.[1] It functions as an inhibitor of Hsp70 and SIRT2.[2] Key physicochemical properties are summarized in the table below.

Q2: What is the primary bioavailability challenge with **YM-08**?

The primary challenge is not necessarily poor aqueous solubility, but rather its rapid metabolism. **YM-08** has a very short half-life of less than three minutes in mouse liver microsome assays, indicating extensive first-pass metabolism. This rapid breakdown is a significant hurdle for achieving sustained therapeutic concentrations, particularly via oral

administration. While designed for brain penetration, strategies to protect the molecule from metabolic degradation are crucial for improving its overall bioavailability.

Q3: Has the oral bioavailability of **YM-08** been determined?

Currently, there is no publicly available data on the oral bioavailability of **YM-08**. Preclinical studies have primarily utilized intravenous (i.v.) or intraperitoneal (i.p.) administration to characterize its pharmacokinetic profile and efficacy.[1]

Q4: What are the known pharmacokinetic parameters of **YM-08** in preclinical models?

Pharmacokinetic studies in CD1 mice following a single intravenous injection have shown that **YM-08** successfully crosses the blood-brain barrier and maintains a brain-to-plasma (B/P) ratio of approximately 0.25 for at least 18 hours.[1] Further details are provided in the data tables below.

Troubleshooting Guide

This guide addresses common issues that may be encountered during experiments with **YM-08**.

Problem	Possible Cause	Suggested Solution
Low or no detectable YM-08 in brain tissue after i.v. administration.	1. Incorrect formulation: YM-08 has limited solubility in simple aqueous solutions.	1. Use the recommended formulation: 30% water, 5% Cremophor, 5% ethanol, and 60% phosphate-buffered saline (PBS) for intravenous injection. [1] YM-08 is reported to be insoluble in saline or 10% DMSO/saline at 20 mg/kg.[1]
2. Rapid metabolism: YM-08 is quickly metabolized by liver microsomes.	2. Ensure rapid tissue harvesting and processing after administration to minimize ex vivo degradation. Consider co-administration with a metabolic inhibitor in exploratory studies, though this will alter the intrinsic pharmacokinetic profile.	
3. Inaccurate bioanalytical method: The method for quantifying YM-08 may lack sensitivity or be prone to interference.	3. Develop and validate a sensitive LC-MS/MS method for the quantification of YM-08 in plasma and brain homogenates.[3][4][5][6]	
High variability in pharmacokinetic data between animals.	1. Inconsistent administration: Variability in injection speed or volume can affect initial drug distribution.	1. Standardize the administration protocol, ensuring consistent injection volumes and rates for all animals.
2. Differences in animal physiology: Age, sex, and health status of the animals can influence drug metabolism and distribution.	2. Use a homogenous group of animals for your studies and report their specific characteristics.	

<p>YM-08 appears inactive in cell-based or in vivo models.</p>	<p>1. Insufficient concentration at the target site: This could be due to poor bioavailability, rapid metabolism, or inefficient transport into the target cells or tissue.</p>	<p>1. For in vivo studies, confirm brain and plasma concentrations of YM-08. For cell-based assays, ensure the compound is soluble in the culture medium and used at an appropriate concentration.</p>
<p>2. Degradation of the compound: YM-08 may be unstable under certain experimental conditions.</p>	<p>2. YM-08 is reported to be relatively stable in water for at least 8 hours at room temperature.[1] However, stability in other buffers or media should be confirmed.</p>	
<p>Difficulty in achieving desired oral bioavailability.</p>	<p>1. Extensive first-pass metabolism: As indicated by microsomal stability assays, this is a major barrier.</p>	<p>1. Explore formulation strategies designed to bypass or reduce first-pass metabolism, such as lymphatic targeting formulations or co-administration with metabolic inhibitors.[7][8]</p>
<p>2. Poor aqueous solubility: While not the primary issue, solubility can still impact dissolution and absorption.</p>	<p>2. Consider nanoparticle formulations (e.g., solid lipid nanoparticles, polymeric nanoparticles) to enhance solubility and dissolution rate. [9][10]</p>	

Quantitative Data Presentation

Table 1: Physicochemical Properties of YM-08

Property	Value	Reference
Molecular Formula	C ₁₉ H ₁₇ N ₃ OS ₂	[11]
Molecular Weight	367.49 g/mol	[11]
Solubility	Soluble in DMSO	[11]
Stability in Water	Stable for at least 8 hours at room temperature (100 µM)	[1]
Microsomal Stability (Mouse Liver)	t _{1/2} < 3 minutes	

Table 2: Pharmacokinetic Parameters of YM-08 in CD1 Mice (Single i.v. Injection)

Parameter	Value	Reference
Brain Tissue		
C _{max}	~4 µg/g	
t _{1/2}	6.8 hours	
AUC _{in∞}	260 ng·h/g	
Plasma		
Brain/Plasma Ratio (at 18 hours)	~0.25	[1]

Note: The detailed plasma pharmacokinetic parameters were not explicitly provided in the primary reference.

Experimental Protocols

In Vivo Administration of YM-08 in Mice (Intravenous)

Objective: To assess the pharmacokinetic profile and central nervous system penetration of YM-08.

Materials:

- **YM-08**
- Vehicle solution: 30% sterile water for injection, 5% Cremophor EL, 5% ethanol, 60% sterile phosphate-buffered saline (PBS)
- CD1 mice (age and sex-matched)
- Syringes and needles for intravenous injection

Procedure:

- Prepare the **YM-08** formulation by first dissolving the compound in ethanol and Cremophor EL, then adding the water and PBS. Ensure the final solution is clear and free of precipitates.
- Administer the **YM-08** formulation to the mice via a single tail vein injection. A typical dose used in studies is 6.6 mg/kg.[1]
- At predetermined time points (e.g., 0.25, 1, 4, 8, 18, and 24 hours) post-injection, collect blood samples via cardiac puncture into tubes containing an anticoagulant (e.g., EDTA).
- Immediately following blood collection, perfuse the mice with saline to remove blood from the tissues.
- Harvest the brain and other tissues of interest.
- Process the blood to separate plasma and store all samples at -80°C until analysis.

Analysis of YM-08 in Plasma and Brain Tissue by LC-MS/MS

Objective: To quantify the concentration of **YM-08** in biological matrices.

Materials:

- Plasma and brain tissue samples from the in vivo study

- Acetonitrile
- Internal standard (a structurally similar compound not present in the samples)
- Formic acid or acetic acid
- High-performance liquid chromatography (HPLC) system coupled with a tandem mass spectrometer (MS/MS)
- C18 reverse-phase HPLC column

Procedure:

- Sample Preparation (Plasma):
 - Thaw plasma samples on ice.
 - Perform a protein precipitation by adding a known volume of cold acetonitrile containing the internal standard to a specific volume of plasma.
 - Vortex the mixture and centrifuge to pellet the precipitated proteins.
 - Transfer the supernatant to a clean tube and evaporate to dryness under a stream of nitrogen.
 - Reconstitute the residue in the mobile phase for LC-MS/MS analysis.
- Sample Preparation (Brain Tissue):
 - Thaw brain tissue on ice and weigh it.
 - Homogenize the tissue in a suitable buffer (e.g., PBS) to create a brain homogenate.
 - Perform protein precipitation on a known volume of the homogenate as described for plasma.
- LC-MS/MS Analysis:
 - Inject the reconstituted samples onto the LC-MS/MS system.

- Separate **YM-08** and the internal standard using a gradient elution on the C18 column. A typical mobile phase could consist of water with 0.1% formic acid (Solvent A) and acetonitrile with 0.1% formic acid (Solvent B).[1]
- Detect and quantify the analytes using multiple reaction monitoring (MRM) mode on the mass spectrometer. Specific precursor-to-product ion transitions for **YM-08** will need to be optimized.
- Data Analysis:
 - Construct a calibration curve using standard solutions of **YM-08** of known concentrations.
 - Determine the concentration of **YM-08** in the samples by comparing the peak area ratio of the analyte to the internal standard against the calibration curve.

Visualizations

Signaling Pathway

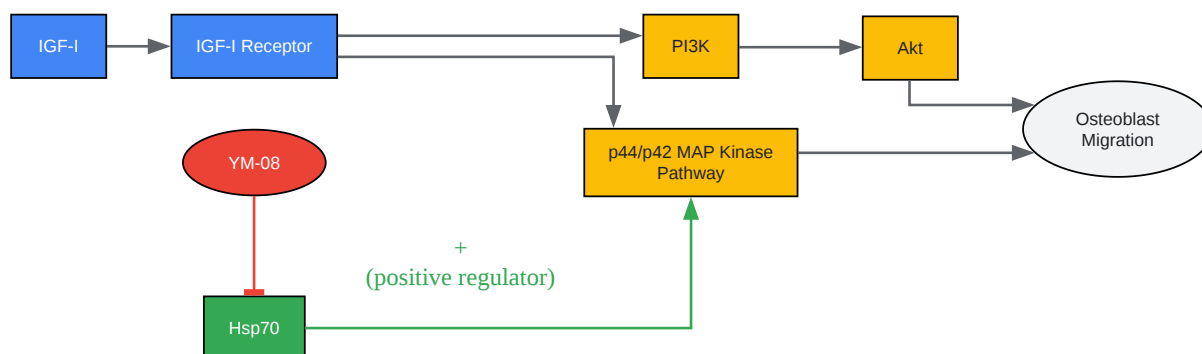

[Click to download full resolution via product page](#)

Caption: IGF-I signaling pathway in osteoblasts and the inhibitory action of **YM-08** on Hsp70.

Experimental Workflow

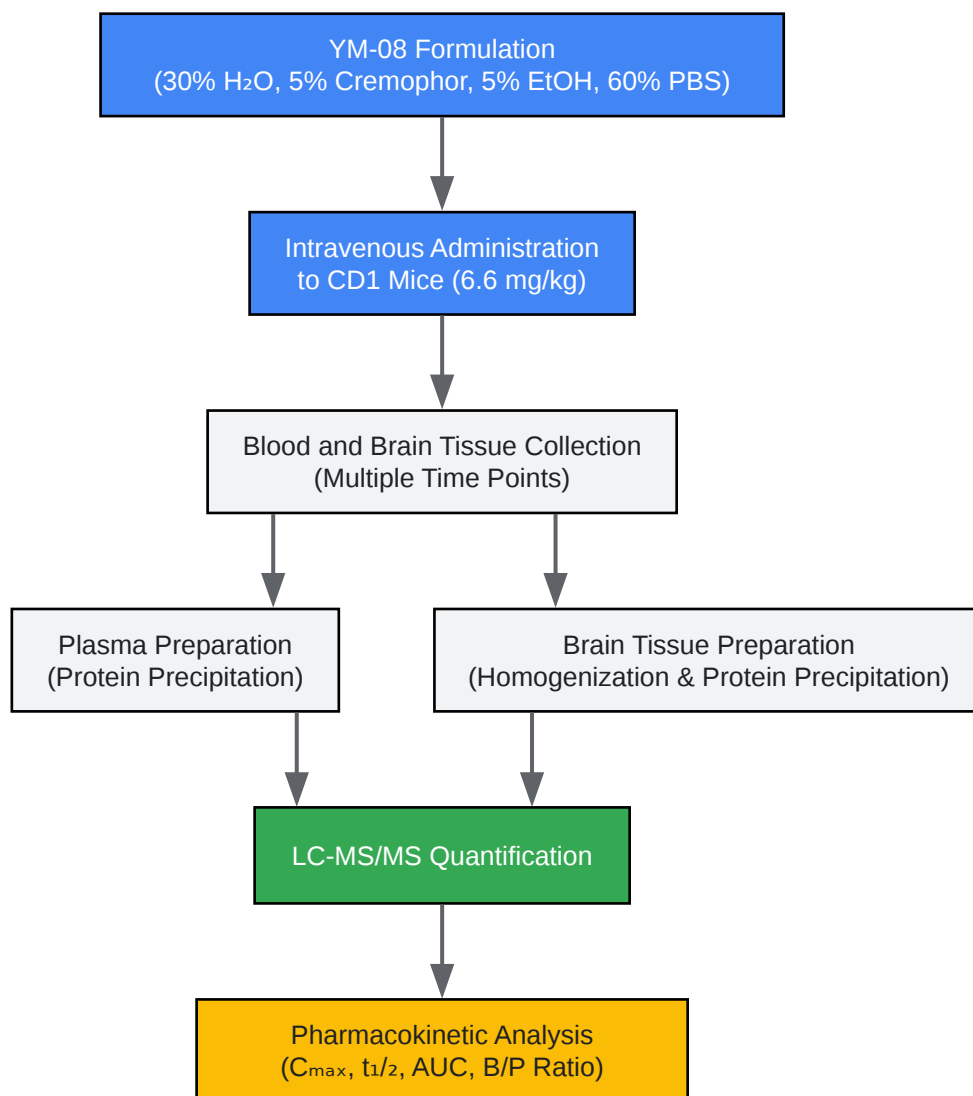

[Click to download full resolution via product page](#)

Caption: Workflow for pharmacokinetic analysis of **YM-08** in mice.

Logical Relationship: Strategies to Improve Oral Bioavailability

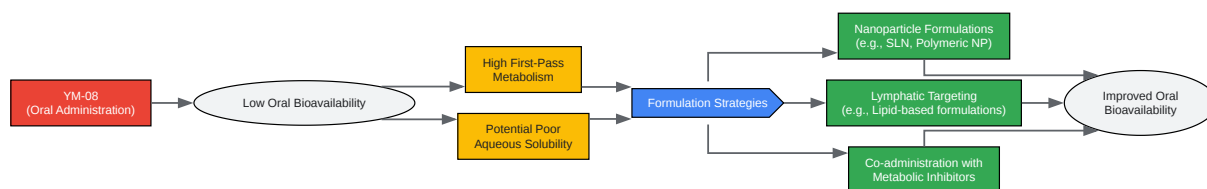

[Click to download full resolution via product page](#)

Caption: Potential strategies to overcome challenges in the oral bioavailability of **YM-08**.

Need Custom Synthesis?

BenchChem offers custom synthesis for rare earth carbides and specific isotopic labeling.

Email: info@benchchem.com or [Request Quote Online](#).

References

- 1. Synthesis and Initial Evaluation of YM-08, a Blood-Brain Barrier Permeable Derivative of the Heat Shock Protein 70 (Hsp70) Inhibitor MKT-077, Which Reduces Tau Levels - PMC [pmc.ncbi.nlm.nih.gov]
- 2. medchemexpress.com [medchemexpress.com]
- 3. A review of sample preparation methods for quantitation of small-molecule analytes in brain tissue by liquid chromatography tandem mass spectrometry (LC-MS/MS) - Analytical Methods (RSC Publishing) [pubs.rsc.org]
- 4. A review of sample preparation methods for quantitation of small-molecule analytes in brain tissue by liquid chromatography tandem mass spectrometry (LC-MS/MS) | Semantic Scholar [semanticscholar.org]
- 5. researchgate.net [researchgate.net]
- 6. A quantitative LC-MS/MS method for determination of a small molecule agonist of EphA2 in mouse plasma and brain tissue - PubMed [pubmed.ncbi.nlm.nih.gov]
- 7. firstwordpharma.com [firstwordpharma.com]

- 8. Novel formulation strategies for improving oral bioavailability of drugs with poor membrane permeation or presystemic metabolism - PubMed [pubmed.ncbi.nlm.nih.gov]
- 9. researchgate.net [researchgate.net]
- 10. pharmaexcipients.com [pharmaexcipients.com]
- 11. YM-08 | CAS 812647-88-4 | Hsp70 Inhibitor | StressMarq Biosciences Inc. [stressmarq.com]
- To cite this document: BenchChem. [Technical Support Center: Improving the Bioavailability of YM-08]. BenchChem, [2026]. [Online PDF]. Available at: [https://www.benchchem.com/product/b12086332/docs#technical-support-center-improving-the-bioavailability-of-ym-08]

Disclaimer & Data Validity:

The information provided in this document is for Research Use Only (RUO) and is strictly not intended for diagnostic or therapeutic procedures. While BenchChem strives to provide accurate protocols, we make no warranties, express or implied, regarding the fitness of this product for every specific experimental setup.

Technical Support: The protocols provided are for reference purposes. Unsure if this reagent suits your experiment?

Need Industrial/Bulk Grade? [Request Custom Synthesis Quote](#)

BenchChem

Our mission is to be the trusted global source of essential and advanced chemicals, empowering scientists and researchers to drive progress in science and industry.

Contact

Address: 3281 E Guasti Rd
Ontario, CA 91761, United States
Phone: (601) 213-4426
Email: info@benchchem.com

Contact our Ph.D. Support Team for a compatibility check