

Introduction to 2'-Modified Ribonucleoside 5'-Triphosphates: A Technical Guide

Author: BenchChem Technical Support Team. **Date:** May 2026

Compound of Interest

Compound Name: 2'-Amino-2'-deoxycytidine-5'-triphosphate

Cat. No.: B12082923

[Get Quote](#)

Executive Summary

The transition from unmodified RNA to "programmable" chemical RNA is the cornerstone of modern therapeutic development. At the center of this shift are 2'-modified ribonucleoside 5'-triphosphates (2'-modified NTPs). These analogs are not merely structural variants; they are functional tools designed to overcome the three primary limitations of native RNA: thermodynamic instability, susceptibility to nuclease degradation, and innate immunogenicity.

This guide provides a mechanistic deep-dive into the behavior, enzymatic incorporation, and quality control of 2'-modified NTPs, specifically focusing on 2'-Fluoro (2'-F) and 2'-O-Methyl (2'-OMe) modifications.

Part 1: Structural Mechanistics & Thermodynamics[1][2]

The ribose 2'-hydroxyl group (-OH) is the "Achilles' heel" of RNA, acting as the nucleophile in phosphodiester bond hydrolysis. Modifying this position alters the sugar pucker, which dictates

the helical geometry (A-form vs. B-form) and thermodynamic stability of the resulting oligonucleotide.

Sugar Pucker and Helical Geometry

The conformation of the ribose ring (sugar pucker) is defined by the electronegativity and steric bulk of the 2'-substituent.

- **2'-Fluoro (2'-F):** Fluorine is highly electronegative. It induces a strong C3'-endo (North) pucker via the gauche effect, locking the RNA into a rigid A-form helix. This pre-organization increases the melting temperature () of duplexes by approximately 1.8°C per modification, driven by favorable enthalpy (enhanced base stacking).
- **2'-O-Methyl (2'-OMe):** This modification adds steric bulk. While it generally favors the C3'-endo conformation, its primary contribution is steric protection against nucleases rather than thermodynamic hyper-stabilization.

The Immune Interface (Self vs. Non-Self)

In mRNA therapeutics, the 2'-OMe modification at the first nucleotide of the 5' cap (Cap 1 structure:

) is a critical molecular signature.

- **Mechanism:** Cytosolic sensors like RIG-I and MDA5 detect viral RNA.[1][2]
- **Evasion:** Host 2'-O-methyltransferases mark mRNA as "self." [3] Absence of this mark triggers the Interferon (IFN) response, suppressing translation and causing inflammation.

Part 2: Enzymatic Incorporation (The Critical Interaction)

Standard T7 RNA Polymerase (WT T7 RNAP) evolved to recognize the 2'-OH of natural NTPs. Modifying this position creates a steric or electrostatic clash within the enzyme's nucleotide-binding pocket, specifically at residue Tyrosine 639 (Y639).

The Gatekeeper Residues

To incorporate 2'-modified NTPs efficiently, engineered polymerases are required.

Enzyme Variant	Key Mutation(s)	Mechanism of Action	Substrate Compatibility
Wild-Type T7	None	Steric gate (Y639) blocks bulky 2'-groups.[4]	Native NTPs, partial 2'-F (inefficient).
Y639F (Single Mutant)	Tyr639 Phe	Removal of the hydroxyl group on Y639 reduces steric clash.	2'-F, 2'-NH , 2'-H (dNTPs).[5][6]
Y639F / H784A (Double Mutant)	Tyr639 PheHis784 Ala	H784A opens the active site further to accommodate bulky adducts.	2'-OMe, 2'-Azido, large modifications.

“

Critical Insight: For 100% replacement of native NTPs with 2'-OMe NTPs, the double mutant (Y639F/H784A) is mandatory. The single mutant (Y639F) will stall or terminate prematurely with bulky modifications.

Visualization: The Incorporation Workflow

The following diagram illustrates the decision matrix for selecting the correct polymerase based on the desired modification.

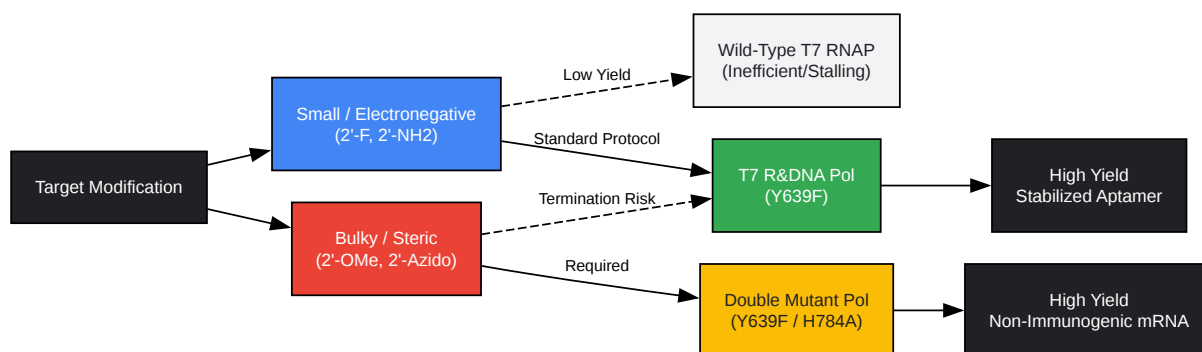

[Click to download full resolution via product page](#)

Caption: Selection logic for T7 RNA Polymerase variants based on 2'-modification sterics.

Part 3: Experimental Protocols

Protocol: Optimized IVT with 2'-Modified NTPs

Objective: Synthesize nuclease-resistant RNA using 2'-F-CTP and 2'-F-UTP. Enzyme: T7 R&DNA Polymerase (Y639F).^{[4][5][6][7][8]}

Reagents:

- DNA Template (Linearized plasmid or PCR product with T7 promoter).
- T7 R&DNA Polymerase Mix.
- 10X Reaction Buffer (400 mM Tris-HCl pH 8.0, Optimized MgCl₂).
- NTP Mix:
 - ATP / GTP (Natural): 5 mM each.
 - 2'-F-CTP / 2'-F-UTP: 5 mM each.

- DTT (10 mM final).

Step-by-Step Methodology:

- Magnesium Titration (Crucial): Modified NTPs chelate Mg differently than OH-NTPs. Furthermore, the fluoride leaving group kinetics differ.
 - Standard: Start at 20 mM MgCl
 - Optimization: Set up 3 parallel reactions at 15 mM, 20 mM, and 30 mM MgCl
- Assembly: Thaw reagents on ice. Add in order: Water
 - Buffer
 - DTT
 - NTPs
 - Template
 - Enzyme.
 - Why? Adding enzyme last prevents premature initiation before all substrates are available, reducing abortive cycling.
- Incubation: Incubate at 37°C for 4-6 hours.
 - Note: Modified NTP incorporation is slower (is lower). Standard 1-2 hour reactions often result in truncated products.
- DNase Treatment: Add DNase I (2 U) and incubate for 15 mins at 37°C to remove template.
- Purification: Silica column or LiCl precipitation. Avoid Ethanol precipitation alone as it often fails to remove unincorporated modified NTPs efficiently.

Protocol: Quality Control via Ion-Pair RP-HPLC

Objective: Quantify purity and verify triphosphate integrity (prevent hydrolysis to NDP/NMP).

System: Agilent 1200 or Waters H-Class with UV detection (254 nm).

Method Parameters:

- Column: C18 Reverse Phase (e.g., Waters XBridge, 3.5 μ m, 4.6 x 100 mm).

- Mobile Phase A: 100 mM KH

PO

, 8 mM TBAHS (Tetrabutylammonium hydrogen sulfate), pH 6.0.

- Mechanism:[2][7][8][9] TBAHS acts as the ion-pairing agent, masking the negative charge of the triphosphate and allowing retention on the hydrophobic C18 resin.
- Mobile Phase B: Methanol (or Acetonitrile).[10]
- Gradient: 0% B to 40% B over 20 minutes.

Acceptance Criteria:

- Purity: > 95% Area Under Curve (AUC).
- Impurity Flag: Any peak eluting before the main peak suggests hydrolysis (NDP/NMP). Any peak eluting after suggests higher phosphorylation (Tetraphosphate) or dimers.

Part 4: Therapeutic Applications & SELEX Aptamer Selection (SELEX)

Aptamers require extreme nuclease stability to survive in serum.

- Strategy: Use 2'-F-Pyrimidines (C/U) and 2'-OH-Purines (A/G).
- Workflow: The Y639F mutant allows the "evolution" of libraries containing 2'-F. The resulting aptamers (e.g., Pegaptanib) have half-lives extended from seconds to hours/days.

mRNA Therapeutics (Cap 1)

For mRNA vaccines, internal 2'-modification (e.g., pseudouridine) suppresses TLR7/8. However, 2'-O-methylation of the Cap is distinct.

- Role: It prevents binding by IFIT1 (Interferon-induced protein with tetratricopeptide repeats 1). IFIT1 sequesters Cap 0 () mRNA, blocking translation.[2] Cap 1 () is invisible to IFIT1.

Visualization: The SELEX Cycle with Modified NTPs

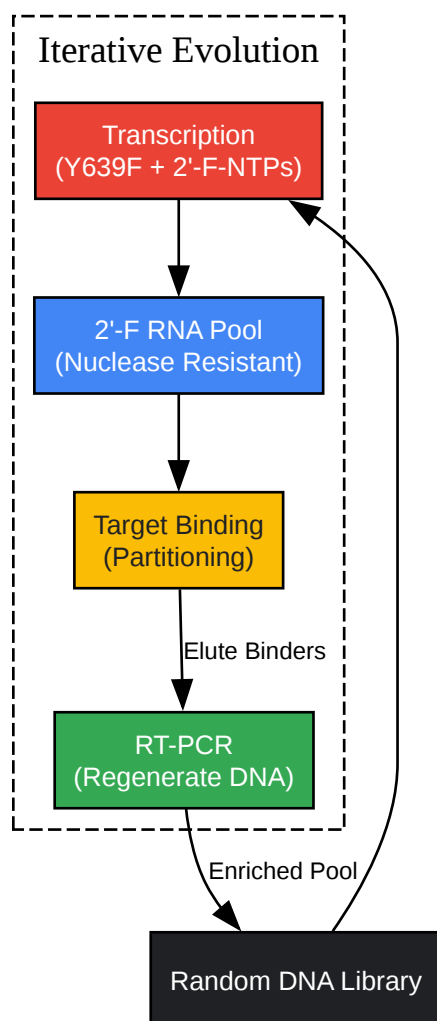

[Click to download full resolution via product page](#)

Caption: SELEX workflow utilizing Y639F polymerase to generate nuclease-resistant aptamers.

References

- Padilla, R., & Sousa, R. (2002).[6] A Y639F/H784A T7 RNA polymerase double mutant displays superior properties for synthesizing RNAs with non-canonical NTPs.[4][6][7] *Nucleic Acids Research*. [11][6][12][13] [Link](#)
- Burmeister, P. E., et al. (2005). Direct in vitro selection of a 2'-O-methyl aptamer to VEGF. *Chemistry & Biology*. [Link](#)
- Daffis, S., et al. (2010).[2] 2'-O-methylation of the viral mRNA cap evades host restriction by IFIT family members.[1] *Nature*. [Link](#)
- Pallan, P. S., et al. (2011). Unexpected origins of the enhanced pairing affinity of 2'-fluoro-modified RNA. *Nucleic Acids Research*. [11][6][12][13] [Link](#)
- Waters Corporation. (2023). Best Practices for Oligonucleotide Analysis Using Ion-Pair Reversed-Phase (IP-RP) Liquid Chromatography. [Link](#)

Need Custom Synthesis?

BenchChem offers custom synthesis for rare earth carbides and specific isotopic labeling.

Email: info@benchchem.com or [Request Quote Online](#).

Sources

- 1. pnas.org [pnas.org]
- 2. Innate immune restriction and antagonism of viral RNA lacking 2'-O methylation - PMC [pmc.ncbi.nlm.nih.gov]
- 3. researchgate.net [researchgate.net]
- 4. A Y639F/H784A T7 RNA polymerase double mutant displays superior properties for synthesizing RNAs with non-canonical NTPs - PMC [pmc.ncbi.nlm.nih.gov]
- 5. T7 R&DNA Polymerase | LGC, Biosearch Technologies [biosearchtech.com]

- [6. A Y639F/H784A T7 RNA polymerase double mutant displays superior properties for synthesizing RNAs with non-canonical NTPs - PubMed \[pubmed.ncbi.nlm.nih.gov\]](#)
- [7. researchgate.net \[researchgate.net\]](#)
- [8. Cambio - Excellence in Molecular Biology \[cambio.co.uk\]](#)
- [9. 2'-Fluoro RNA Shows Increased Watson-Crick H-Bonding Strength and Stacking relative to RNA: Evidence from NMR and Thermodynamic Data - PMC \[pmc.ncbi.nlm.nih.gov\]](#)
- [10. longdom.org \[longdom.org\]](#)
- [11. The Effect of 2'-F-RNA on I-Motif Structure and Stability \[mdpi.com\]](#)
- [12. waters.com \[waters.com\]](#)
- [13. bitesizebio.com \[bitesizebio.com\]](#)
- To cite this document: BenchChem. [Introduction to 2'-Modified Ribonucleoside 5'-Triphosphates: A Technical Guide]. BenchChem, [2026]. [Online PDF]. Available at: [\[https://www.benchchem.com/product/b12082923/docs#introduction-to-2-modified-ribonucleoside-5-triphosphates-a-technical-guide\]](https://www.benchchem.com/product/b12082923/docs#introduction-to-2-modified-ribonucleoside-5-triphosphates-a-technical-guide)

Disclaimer & Data Validity:

The information provided in this document is for Research Use Only (RUO) and is strictly not intended for diagnostic or therapeutic procedures. While BenchChem strives to provide accurate protocols, we make no warranties, express or implied, regarding the fitness of this product for every specific experimental setup.

Technical Support: The protocols provided are for reference purposes. Unsure if this reagent suits your experiment?

Need Industrial/Bulk Grade? [Request Custom Synthesis Quote](#)

BenchChem

Our mission is to be the trusted global source of essential and advanced chemicals, empowering scientists and researchers to drive progress in science and industry.

Contact

Address: 3281 E Guasti Rd
Ontario, CA 91761, United States
Phone: (601) 213-4426
Email: info@benchchem.com

Contact our Ph.D. Support Team for a compatibility check