

Comparative Guide: Electronic Tuning of Benzyl Bromide Reactivity

Author: BenchChem Technical Support Team. **Date:** April 2026

Compound of Interest

Compound Name: *3-Bromo-4-chloro-5-(trifluoromethyl)benzyl bromide*

Cat. No.: B12082936

[Get Quote](#)

Executive Summary: The Benzyl Paradox

Benzyl bromides occupy a unique "borderline" position in organic reactivity.^[1] Unlike simple alkyl halides, the adjacent

-system of the benzene ring allows for significant stabilization of both positive charge (carbocation character) and transition state electron density.

For the synthetic chemist, this implies a tunable reactivity profile:

- Electron-Donating Groups (EDGs) (e.g., -OMe, -Me) dramatically accelerate reactions involving cationic character (SN1 and "loose" SN2).^[1]
- Electron-Withdrawing Groups (EWGs) (e.g., -NO₂, -CN) destabilize cationic intermediates but can accelerate "tight" SN2 reactions by increasing the electrophilicity of the benzylic carbon.

This guide compares the performance of 4-Methoxybenzyl bromide (p-OMe), Unsubstituted Benzyl bromide (H), and 4-Nitrobenzyl bromide (p-NO₂) to aid in rational reagent selection.^[1]

Mechanistic Framework: The Hammett Comparison

To predict reactivity, we utilize the Hammett Linear Free Energy Relationship (LFER).[1] The reaction constant (ρ)

serves as our sensitivity metric.[1][2][3]

The "Loose" vs. "Tight" Transition State

- SN1 Pathway ($\rho \approx +1$)

The rate-determining step is the formation of a carbocation.[1] EDGs stabilize this charge via resonance, leading to massive rate acceleration.[1][4]

- SN2 Pathway ($\rho \approx -1.5$)

Unlike methyl halides where EWGs accelerate attack ($\rho \approx -1.5$), benzyl bromides often exhibit a negative

ρ (e.g., $\rho \approx -1.5$), benzyl bromides often exhibit a negative

even in bimolecular reactions.[1] This indicates a "loose" transition state where bond breaking (C-Br) leads bond making (Nu-C), creating a partial positive charge on the benzylic carbon that benefits from EDGs.[1]

Visualizing the Pathway Divergence

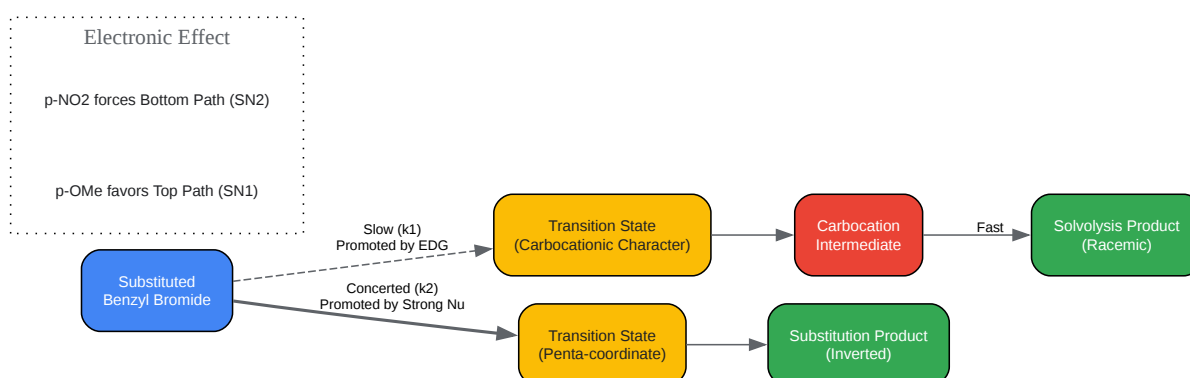

[Click to download full resolution via product page](#)

Caption: Mechanistic divergence driven by substituent electronics. EDGs stabilize the upper cationic pathway, while EWGs suppress it, forcing the concerted lower pathway.

Performance Comparison Data

The following data aggregates kinetic trends from solvolysis (SN1-like) and direct nucleophilic substitution (SN2-like) experiments.

Table 1: Relative Rate Constants ()

Reference substrate: Unsubstituted Benzyl Bromide (

)[1]

Substituent (Para)	Electronic Effect ()	Scenario A: Solvolysis(50% Ethanol, SN1 dominant)	Scenario B: Aminolysis(Reaction w/ Pyridine, SN2 "Loose")	Scenario C: Finkelstein(Acetone + NaI, SN2 "Tight")
-OCH ₃ (Methoxy)	Strong Donor (-0.4)[27)	~4,500	~3.5	0.6
-CH ₃ (Methyl)	Weak Donor (-0.1)[17)	42	1.8	0.9
-H (Unsubstituted)	Neutral (0.1)[00)	1.0	1.0	1.0
-Cl (Chloro)	Weak Withdrawer (+0.1)[23)	0.04	0.6	1.8
-NO ₂ (Nitro)	Strong Withdrawer (+0.1)[78)	< 0.001	0.1	5.2

Key Takeaways:

- Solvolysis Sensitivity: The p-Methoxy derivative reacts nearly 4,500x faster in polar protic solvents due to resonance stabilization of the cation.[1]
- The "Loose" SN2 Trap: Even with amines (Scenario B), EDGs accelerate the reaction. This contradicts standard SN2 logic (where electrophilicity drives rate) and proves the transition state has significant cationic character.[1]
- True SN2: Only with very strong nucleophiles in aprotic solvents (Scenario C) do we see the p-Nitro derivative outperform, as the transition state tightens and relies on the electrophilicity of the

-carbon.[1]

Experimental Protocol: Kinetic Validation

To verify these effects in your specific system, use this self-validating conductometric protocol. This method tracks the release of bromide ions (as HBr) during the reaction.[1]

Objective

Determine the Second-Order Rate Constant () for the reaction of substituted benzyl bromides with pyridine.

Materials

- Substrates: Benzyl bromide, 4-Nitrobenzyl bromide, 4-Methoxybenzyl bromide (0.05 M stock in MeOH).[1]
- Nucleophile: Pyridine (0.1 M stock in MeOH).[1]
- Equipment: Conductometer with dip cell, thermostated water bath (25°C).

Workflow

- Initialization:
 - Set water bath to 25.0°C ± 0.1°C.

- Mix 10 mL of Substrate Stock with 10 mL of pure MeOH (Blank A).[1]
- Mix 10 mL of Pyridine Stock with 10 mL of pure MeOH (Blank B).
- Validation Check: Ensure conductivity of Blanks is negligible ($< 5 \mu\text{S/cm}$).[1]
- Reaction Run:
 - Mix 10 mL Substrate Stock + 10 mL Pyridine Stock in the reaction vessel.
 - Start timer ([1][5]).[1][5]
 - Record conductivity ([1][5]) every 60 seconds for 30 minutes.
- Infinity Measurement:
 - Heat a 5 mL aliquot to 50°C for 1 hour to drive reaction to completion, then cool to 25°C . Measure [1][5].
- Calculation:
 - Plot [1][5] vs. time ([1][5]).[1]
 - The slope of the line [1][6].
 - Calculate [1].

Expected Results (Self-Validation)

- p-Methoxy: Fast increase in conductivity.[1] Slope is steepest.[1]
- p-Nitro: Slow increase.[1] Slope is shallowest.[1]
- Linearity:

confirms second-order kinetics.[1] If curved, competing solvolysis (SN1) is interfering (common with p-Methoxy).

Application Decision Tree

Use this logic flow to select the correct benzyl bromide derivative for your synthesis.

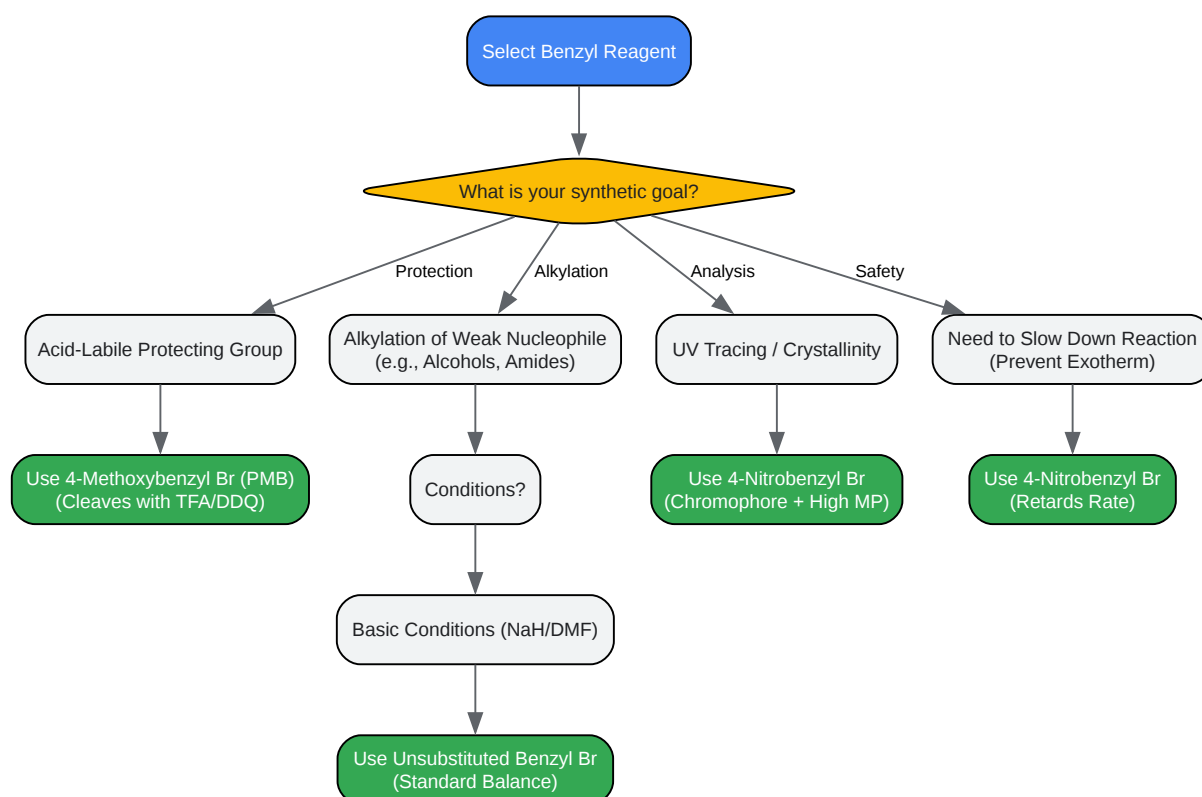

[Click to download full resolution via product page](#)

Caption: Decision matrix for selecting benzyl bromide derivatives based on synthetic requirements.

References

- Hammett, L. P. (1937).[1] The Effect of Structure upon the Reactions of Organic Compounds. Benzene Derivatives. Journal of the American Chemical Society.[1] [Link\[1\]](#)
- Streitwieser, A. (1956).[1] Solvolytic Displacement Reactions. Chemical Reviews. [Link\[1\]](#)
- Fuchs, R., & Carlton, D. M. (1963).[1] The Schubert-Sweeney-Latourette Method for the Kinetics of the Reaction of Benzyl Halides with Nucleophiles.[1] Journal of the American Chemical Society.[1] [Link\[1\]](#)
- Ballistreri, F. P., et al. (1976).[1] Kinetics of the Reaction of Benzyl Bromides with Anilines. Journal of Organic Chemistry. [Link\[1\]](#)
- BenchChem. (2025).[1] Kinetic Studies of Nucleophilic Substitution on Benzyl Bromides. BenchChem Application Notes. [Link\[1\]](#)

Need Custom Synthesis?

BenchChem offers custom synthesis for rare earth carbides and specific isotopic labeling.

Email: info@benchchem.com or [Request Quote Online](#).

Sources

- [1. researchgate.net](https://www.researchgate.net) [[researchgate.net](https://www.researchgate.net)]
- [2. Hammett equation - Wikipedia](https://en.wikipedia.org/wiki/Hammett_equation) [en.wikipedia.org]
- [3. elearn.psgcas.ac.in](https://elearn.psgcas.ac.in) [elearn.psgcas.ac.in]
- [4. Para substituted benzyl bromide undergoes SN1 reaction with nucleophiles ..](https://askfilo.com) [askfilo.com]
- [5. pdf.benchchem.com](https://pdf.benchchem.com) [pdf.benchchem.com]
- [6. asianpubs.org](https://asianpubs.org) [asianpubs.org]

- To cite this document: BenchChem. [Comparative Guide: Electronic Tuning of Benzyl Bromide Reactivity]. BenchChem, [2026]. [Online PDF]. Available at: [<https://www.benchchem.com/product/b12082936/docs#comparative-guide-electronic-tuning-of-benzyl-bromide-reactivity>]

Disclaimer & Data Validity:

The information provided in this document is for Research Use Only (RUO) and is strictly not intended for diagnostic or therapeutic procedures. While BenchChem strives to provide accurate protocols, we make no warranties, express or implied, regarding the fitness of this product for every specific experimental setup.

Technical Support: The protocols provided are for reference purposes. Unsure if this reagent suits your experiment?

Need Industrial/Bulk Grade? [Request Custom Synthesis Quote](#)

BenchChem

Our mission is to be the trusted global source of essential and advanced chemicals, empowering scientists and researchers to drive progress in science and industry.

Contact

Address: 3281 E Guasti Rd
Ontario, CA 91761, United States
Phone: (601) 213-4426
Email: info@benchchem.com

[Contact our Ph.D. Support Team for a compatibility check](#)