

Replicating and validating published research findings on Suprofen

Author: BenchChem Technical Support Team. **Date:** April 2026

Compound of Interest

Compound Name: *Suprofen*
CAS No.: *52671-39-3*
Cat. No.: *B1208504*

[Get Quote](#)

A Comparative Guide to Suprofen for Researchers

This guide provides a detailed comparison of Suprofen with other common non-steroidal anti-inflammatory drugs (NSAIDs), focusing on its mechanism of action, in vitro potency, and in vivo anti-inflammatory effects. The information is intended for researchers, scientists, and professionals in drug development to support efforts in replicating and validating published findings.

Mechanism of Action: Cyclooxygenase Inhibition

Suprofen, a derivative of 2-acetylthiophene, is a non-steroidal anti-inflammatory drug with analgesic and antipyretic properties.[1] Like other traditional NSAIDs, its primary mechanism of action is the inhibition of the cyclooxygenase (COX) enzymes, COX-1 and COX-2.[2][3] These enzymes are responsible for converting arachidonic acid into prostaglandins, which are key signaling molecules in the inflammation cascade.[2] By binding to and inhibiting these enzymes, Suprofen effectively reduces the synthesis of prostaglandins, thereby mitigating pain and inflammation.[4]

The inhibition of COX-1 is also associated with common NSAID-related side effects, such as gastrointestinal issues, because this isoform is involved in maintaining the protective lining of the stomach.[2] COX-2, on the other hand, is primarily induced during inflammatory responses. [2]

Prostaglandin Synthesis Pathway and NSAID Inhibition

The following diagram illustrates the role of COX enzymes in the prostaglandin synthesis pathway and the point of inhibition by NSAIDs like Suprofen.

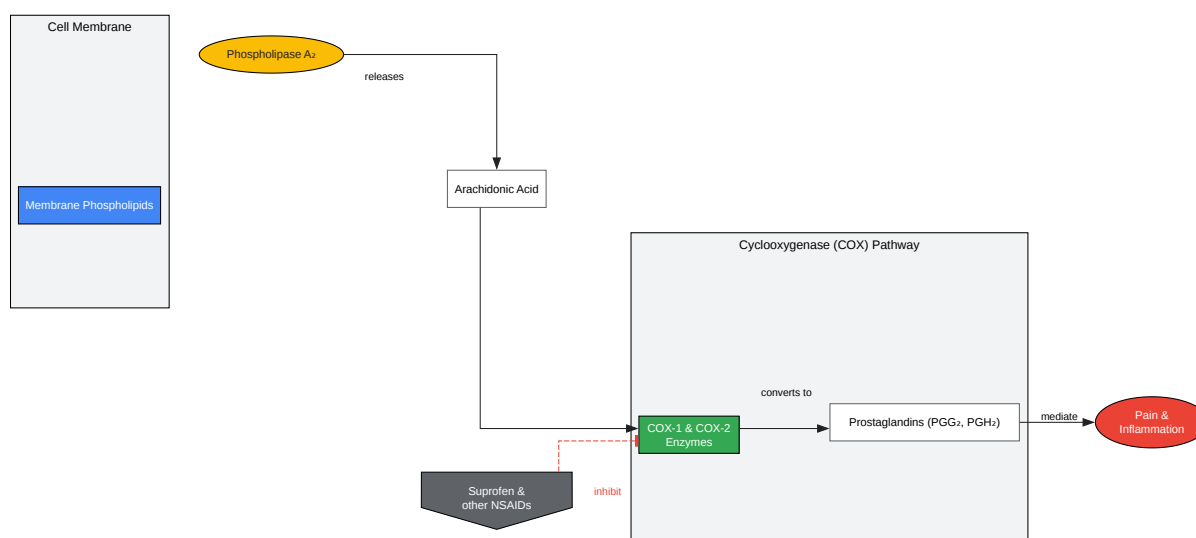

[Click to download full resolution via product page](#)

Caption: Mechanism of Suprofen via COX enzyme inhibition. (Within 100 characters)

Comparative In Vitro Potency (IC₅₀ Values)

The potency of NSAIDs is often measured by their half-maximal inhibitory concentration (IC₅₀) against COX-1 and COX-2. While specific, directly comparable IC₅₀ values for Suprofen are not readily available in recent literature, data for common comparators like Ibuprofen and Ketoprofen have been published. The S-enantiomers of these chiral drugs are the more pharmacologically active forms.[5][6]

The table below summarizes the IC₅₀ values for several NSAIDs from an in vitro assay using human peripheral monocytes. This provides a benchmark for the expected potency of non-selective and selective inhibitors.

Drug	COX-1 IC ₅₀ (μM)	COX-2 IC ₅₀ (μM)	Selectivity Ratio (COX-1/COX-2)
Ibuprofen	12	80	0.15
Ketoprofen	Data not available in this specific study	Data not available in this specific study	N/A
Diclofenac	0.076	0.026	2.9
Indomethacin	0.0090	0.31	0.029
Celecoxib	82	6.8	12

(Data sourced from a study on human peripheral monocytes)

Note: Lower IC₅₀ values indicate greater potency. A higher selectivity ratio indicates greater selectivity for COX-2 over COX-1. Suprofen is structurally related to Ibuprofen and Ketoprofen. [4]

Comparative In Vivo Anti-Inflammatory Efficacy

The carrageenan-induced paw edema model in rats is a standard in vivo assay to evaluate the anti-inflammatory activity of NSAIDs. The effectiveness is often reported as the dose required to produce a 50% reduction in edema (ED₅₀) or the percentage of edema inhibition at a specific dose.

While a direct head-to-head study with quantitative data for Suprofen, Ibuprofen, and Ketoprofen in this specific model is not available in the cited literature, clinical studies in humans provide some comparative insights. In a 14-day study on patients with osteoarthritis, Suprofen (800 mg/day) was found to have a slightly faster onset of pain relief compared to Ibuprofen (1600 mg/day), with both drugs being rated as having "good to very good" efficacy by over 75% of patients and investigators.[1][7]

Treatment Group	Daily Dose	Mean Onset of Pain Relief	Patient-Reported Efficacy (Good to Very Good)
Suprofen	800 mg	3.3 days	>75%
Ibuprofen	1600 mg	3.9 days	>75%

(Data from a 14-day clinical study in osteoarthritis patients)

[\[1\]](#)

Experimental Protocols for Validation

To facilitate the replication of findings, detailed methodologies for key assays are provided below.

In Vitro COX Inhibition Assay (Human Whole Blood Model)

This assay provides a physiologically relevant environment to assess the COX-inhibitory activity of a compound.

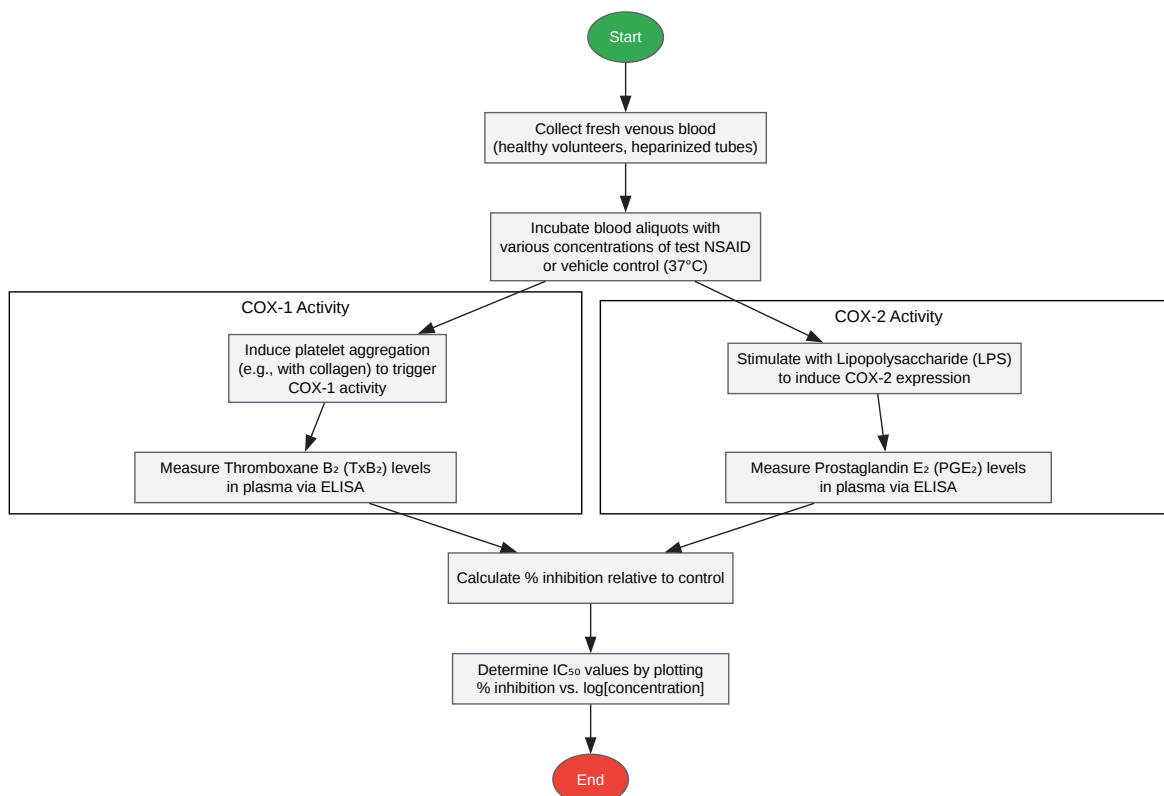

[Click to download full resolution via product page](#)

Caption: Workflow for a human whole blood COX inhibition assay. (Within 100 characters)

Methodology:

- Blood Collection: Fresh venous blood is drawn from healthy, drug-free volunteers into heparinized tubes.
- Incubation: Aliquots of blood are incubated with various concentrations of the test compound (e.g., Suprofen) or a vehicle control for a specified time (e.g., 60 minutes) at 37°C.[8]
- COX-1 Activity Assessment: To measure COX-1 activity, blood coagulation is allowed to occur, which stimulates platelets to produce Thromboxane B₂ (TxB₂), a stable metabolite of the COX-1 product TxA₂. The reaction is stopped, and plasma is collected for analysis.[8]

- **COX-2 Activity Assessment:** To measure COX-2 activity, blood aliquots are first incubated with an inflammatory stimulus like Lipopolysaccharide (LPS) to induce COX-2 expression in monocytes. After this induction period, the test compound is added. The primary product of COX-2 in this system, Prostaglandin E₂ (PGE₂), is then measured in the plasma.[8]
- **Quantification:** TxB₂ and PGE₂ levels are quantified using a validated Enzyme-Linked Immunosorbent Assay (ELISA).
- **Data Analysis:** The percentage of inhibition for both TxB₂ and PGE₂ production is calculated for each concentration of the test drug relative to the vehicle control. IC₅₀ values are determined by fitting the concentration-response data to a suitable pharmacological model. [8]

In Vivo Carrageenan-Induced Paw Edema in Rats

This is a widely used model for evaluating acute anti-inflammatory activity.[9][10][11]

Methodology:

- **Animal Acclimatization:** Male Wistar rats (or a similar strain) weighing 180-200g are acclimatized to laboratory conditions for at least one week.
- **Grouping and Dosing:** Animals are divided into several groups: a control group (vehicle), a positive control group (e.g., Indomethacin, 10 mg/kg), and test groups receiving various doses of Suprofen.[10] The drugs are typically administered orally or intraperitoneally 30-60 minutes before the carrageenan injection.
- **Induction of Edema:** A sub-plantar injection of 0.1 mL of a 1% carrageenan suspension is administered into the right hind paw of each rat.[9]
- **Measurement of Paw Volume:** The paw volume is measured immediately before the carrageenan injection and at regular intervals afterward (e.g., 1, 2, 3, 4, and 5 hours) using a plethysmometer.[10][11]
- **Data Analysis:** The degree of swelling is calculated by subtracting the initial paw volume from the post-injection volume. The percentage inhibition of edema for the drug-treated groups is

calculated using the formula: % Inhibition = ((Mean Edema of Control - Mean Edema of Test) / Mean Edema of Control) x 100[9]

- ED₅₀ Calculation: If multiple doses are tested, the ED₅₀ value (the dose causing 50% inhibition of edema) can be calculated from the dose-response curve.

Need Custom Synthesis?

BenchChem offers custom synthesis for rare earth carbides and specific isotopic labeling.

Email: info@benchchem.com or [Request Quote Online](#).

References

- 1. [benchchem.com](https://www.benchchem.com) [[benchchem.com](https://www.benchchem.com)]
- 2. What is the mechanism of Suprofen? [synapse.patsnap.com]
- 3. [taylorandfrancis.com](https://www.taylorandfrancis.com) [[taylorandfrancis.com](https://www.taylorandfrancis.com)]
- 4. Suprofen. A review of its pharmacodynamic and pharmacokinetic properties, and analgesic efficacy - PubMed [pubmed.ncbi.nlm.nih.gov]
- 5. Inhibition of cyclooxygenase-1 and -2 by R(-)- and S(+)-ibuprofen - PubMed [pubmed.ncbi.nlm.nih.gov]
- 6. Inhibition of Cyclooxygenase-1 and -2 by R(-)- and S(+)-Ibuprofen | Semantic Scholar [[semanticscholar.org](https://www.semanticscholar.org)]
- 7. Comparison of suprofen and ibuprofen in the treatment of pain secondary to osteoarthritis - PubMed [pubmed.ncbi.nlm.nih.gov]
- 8. [benchchem.com](https://www.benchchem.com) [[benchchem.com](https://www.benchchem.com)]
- 9. [mdpi.com](https://www.mdpi.com) [[mdpi.com](https://www.mdpi.com)]
- 10. Rat paw oedema modeling and NSAIDs: Timing of effects - PubMed [pubmed.ncbi.nlm.nih.gov]
- 11. A study of the mechanisms underlying the anti-inflammatory effect of ellagic acid in carrageenan-induced paw edema in rats - PMC [[pmc.ncbi.nlm.nih.gov](https://pubmed.ncbi.nlm.nih.gov)]
- To cite this document: BenchChem. [Replicating and validating published research findings on Suprofen]. BenchChem, [2026]. [Online PDF]. Available at: [<https://www.benchchem.com/product/b1208504/docs#replicating-and-validating-published-research-findings-on-suprofen>]

Disclaimer & Data Validity:

The information provided in this document is for Research Use Only (RUO) and is strictly not intended for diagnostic or therapeutic procedures. While BenchChem strives to provide accurate protocols, we make no warranties, express or implied, regarding the fitness of this product for every specific experimental setup.

Technical Support: The protocols provided are for reference purposes. Unsure if this reagent suits your experiment?

Need Industrial/Bulk Grade? [Request Custom Synthesis Quote](#)

BenchChem

Our mission is to be the trusted global source of essential and advanced chemicals, empowering scientists and researchers to drive progress in science and industry.

Contact

Address: 3281 E Guasti Rd
Ontario, CA 91761, United States
Phone: (601) 213-4426
Email: info@benchchem.com

[Contact our Ph.D. Support Team for a compatibility check](#)