

Addressing inconsistent results in Broussin bioactivity assays

Author: BenchChem Technical Support Team. **Date:** April 2026

Compound of Interest

Compound Name: *Broussin*
CAS No.: 76045-50-6
Cat. No.: B1208535

[Get Quote](#)

Technical Support Center: Broussin Bioactivity Assays

Welcome to the technical support center for **Broussin** bioactivity assays. This resource is designed for researchers, scientists, and drug development professionals to address common challenges and ensure the generation of consistent and reliable data in their experiments.

Frequently Asked Questions (FAQs)

Q1: What is **Broussin** and what are its reported bioactivities?

Broussin is a flavan-class flavonoid compound found in plants of the Broussonetia genus. Flavonoids, as a group, are known for a wide range of pharmacological effects. Active compounds isolated from Broussonetia have been shown to possess antitumor, antioxidant, anti-inflammatory, antidiabetic, antibacterial, and antiviral properties, among others.

Q2: I am observing high variability between replicate wells in my cell-based assay with **Broussin**. What are the common causes?

High variability in cell-based assays can stem from several factors. One of the most common issues with flavonoids like **Broussin** is poor aqueous solubility.[1][2] This can lead to inconsistent concentrations in your assay wells. Other potential causes include inconsistent cell seeding density, "edge effects" in microplates where outer wells evaporate more quickly, and pipetting errors.

Q3: My **Broussin** stock solution is difficult to dissolve. What is the recommended procedure?

Broussin, like many flavonoids, has low solubility in water. It is typically recommended to dissolve **Broussin** in an organic solvent such as dimethyl sulfoxide (DMSO) to create a concentrated stock solution. For your experiments, this stock can then be diluted in the appropriate aqueous assay buffer. It is critical to ensure the final concentration of DMSO in your assay is low (typically under 0.5%) to avoid solvent-induced artifacts that could affect your results.

Q4: The bioactivity I'm measuring is lower than expected based on the literature for similar flavonoids. What could be the reason?

Underestimated bioactivity can be a direct consequence of the low solubility of flavonoids.[2][3] If **Broussin** precipitates out of solution in your aqueous assay medium, the effective concentration will be lower than intended. Additionally, ensure that your assay conditions (e.g., pH, temperature) are optimal and that the reagents have not degraded. It is also worth noting that aglycone flavonoids (like **Broussin**) are often more potent antioxidants than their glycoside counterparts.[4]

Q5: Are there any known signaling pathways that **Broussin** is likely to modulate?

While specific research on **Broussin**'s signaling pathways is emerging, related flavonoid compounds have been shown to modulate key inflammatory and cancer-related pathways. For example, Broussonin C has been observed to suppress pro-inflammatory mediators through the MAPK and JAK-STAT signaling pathways in macrophages.[5] Other flavonoids, such as morusin, have been found to exert anticancer effects through the PI3K-Akt signaling pathway.[6]

Troubleshooting Guides

This section provides structured guidance to resolve specific issues you may encounter during your **Broussin** bioactivity assays.

Issue 1: Inconsistent Results and High Standard Deviations

This is a common problem when working with flavonoids and can often be traced back to issues with compound solubility and dispensing.

Troubleshooting Workflow:

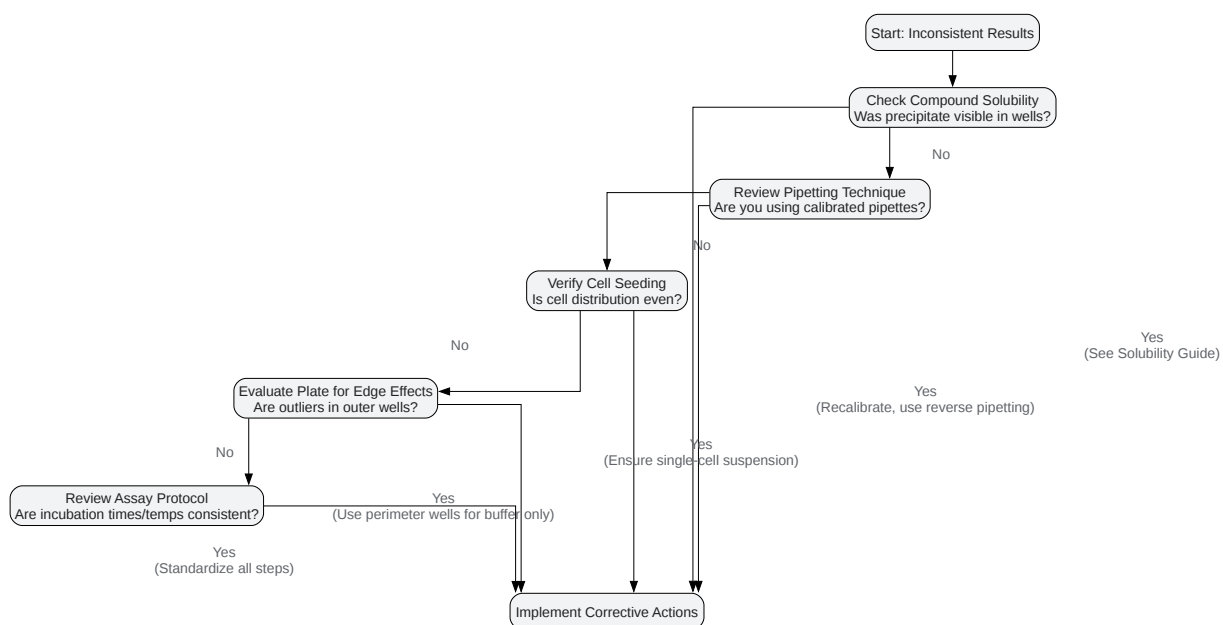

[Click to download full resolution via product page](#)

Caption: Troubleshooting workflow for inconsistent assay results.

Corrective Actions:

- **Improve Solubility:** Prepare a higher concentration stock in 100% DMSO and perform serial dilutions. Ensure the final DMSO concentration in the assay is minimal and consistent across all wells. Consider using a solubility enhancer if compatible with your assay.
- **Pipetting:** Ensure pipettes are calibrated. For viscous solutions or small volumes, use reverse pipetting techniques. Use a multi-channel pipette for adding reagents to reduce timing variability between wells.
- **Cell Seeding:** Before seeding, ensure cells are in a single-cell suspension and evenly distributed in the flask.
- **Edge Effects:** To minimize evaporation, do not use the outermost wells for experimental data. Instead, fill them with sterile media or PBS.

Issue 2: Low or No Bioactivity Detected

If **Broussin** appears inactive in your assay, it may be due to compound-related issues or problems with the assay itself.

Troubleshooting Steps:

- **Confirm Compound Integrity:**
 - Has the compound been stored correctly (protected from light, at the appropriate temperature)?
 - Prepare fresh dilutions from your stock solution for each experiment.
- **Address Solubility Issues:**
 - As mentioned previously, poor solubility is a primary reason for lack of activity.^{[2][3]} Ensure **Broussin** is fully dissolved in your assay medium. You can visually inspect for precipitation under a microscope.
- **Validate Assay Performance:**

- Include a positive control for your assay to confirm that the assay is working correctly. For example, in a tyrosinase inhibition assay, kojic acid can be used as a positive control.[7]
- Check that all reagents are within their expiration dates and have been stored properly.
- Verify that the plate reader is set to the correct wavelength for your assay's endpoint measurement.

Quantitative Data Summary

The following tables provide examples of quantitative data that can be generated from common bioactivity assays for flavonoids. Note that the specific values for **Broussonin** will need to be determined experimentally.

Table 1: Antioxidant Activity of a Flavonoid (Example Data)

| Assay Type | Parameter | Value | Positive Control |
|---|------------------|---------|---|
| DPPH Radical Scavenging | IC ₅₀ | 15.2 μM | Ascorbic Acid (IC ₅₀ = 8.5 μM) |
| Oxygen Radical Absorbance Capacity (ORAC) | μmol TE/μmol | 6.8 | Quercetin (μmol TE/μmol = 12.1) |
| Cellular Antioxidant Activity (CAA) | EC ₅₀ | 25.7 μM | Quercetin (EC ₅₀ = 10.3 μM) |

Table 2: Anti-inflammatory Effects of Broussonin C in LPS-Stimulated Macrophages[5]

| Mediator | Parameter | Value |
|---|------------------|---------|
| Nitric Oxide (NO) Production | IC ₅₀ | 12.5 μM |
| Prostaglandin E ₂ (PGE ₂) Production | IC ₅₀ | 9.8 μM |
| Tumor Necrosis Factor-α (TNF-α) | IC ₅₀ | 15.2 μM |
| Interleukin-6 (IL-6) | IC ₅₀ | 18.1 μM |

Experimental Protocols

Protocol 1: DPPH Radical Scavenging Assay

This assay measures the ability of an antioxidant to scavenge the stable 2,2-diphenyl-1-picrylhydrazyl (DPPH) radical.

Materials:

- **Broussin**
- DPPH solution (0.1 mM in methanol)
- Methanol
- 96-well microplate
- Microplate reader

Procedure:

- Prepare serial dilutions of **Broussin** in methanol.
- In a 96-well plate, add 100 μL of each **Broussin** dilution.
- Add 100 μL of the DPPH solution to each well.
- For the control, add 100 μL of methanol and 100 μL of the DPPH solution.

- Incubate the plate in the dark at room temperature for 30 minutes.
- Measure the absorbance at 517 nm.
- Calculate the percentage of DPPH scavenging activity for each concentration and determine the IC₅₀ value.

Protocol 2: Tyrosinase Inhibition Assay

This assay is used to screen for inhibitors of tyrosinase, an enzyme involved in melanin production.^[8]

Materials:

- **Broussin** dissolved in DMSO
- Mushroom tyrosinase solution
- L-DOPA solution (substrate)
- Phosphate buffer (pH 6.8)
- 96-well microplate
- Microplate reader

Procedure:

- Prepare serial dilutions of **Broussin** in phosphate buffer (ensure final DMSO concentration is low).
- Add 80 µL of each **Broussin** dilution to the wells of a 96-well plate.
- Add 40 µL of the tyrosinase solution to each well and pre-incubate at 25°C for 10 minutes.
- Initiate the reaction by adding 80 µL of the L-DOPA solution to each well.
- Measure the absorbance at 475 nm at regular intervals to determine the reaction rate.

- Calculate the percentage of tyrosinase inhibition for each concentration and determine the IC_{50} value. Kojic acid can be used as a positive control inhibitor.[7]

Signaling Pathways and Workflows

Broussin Anti-Inflammatory Signaling Pathway (Hypothesized)

Based on data from related flavonoids, **Broussin** may exert anti-inflammatory effects by inhibiting key signaling pathways such as MAPK and JAK-STAT in immune cells like macrophages.[5]

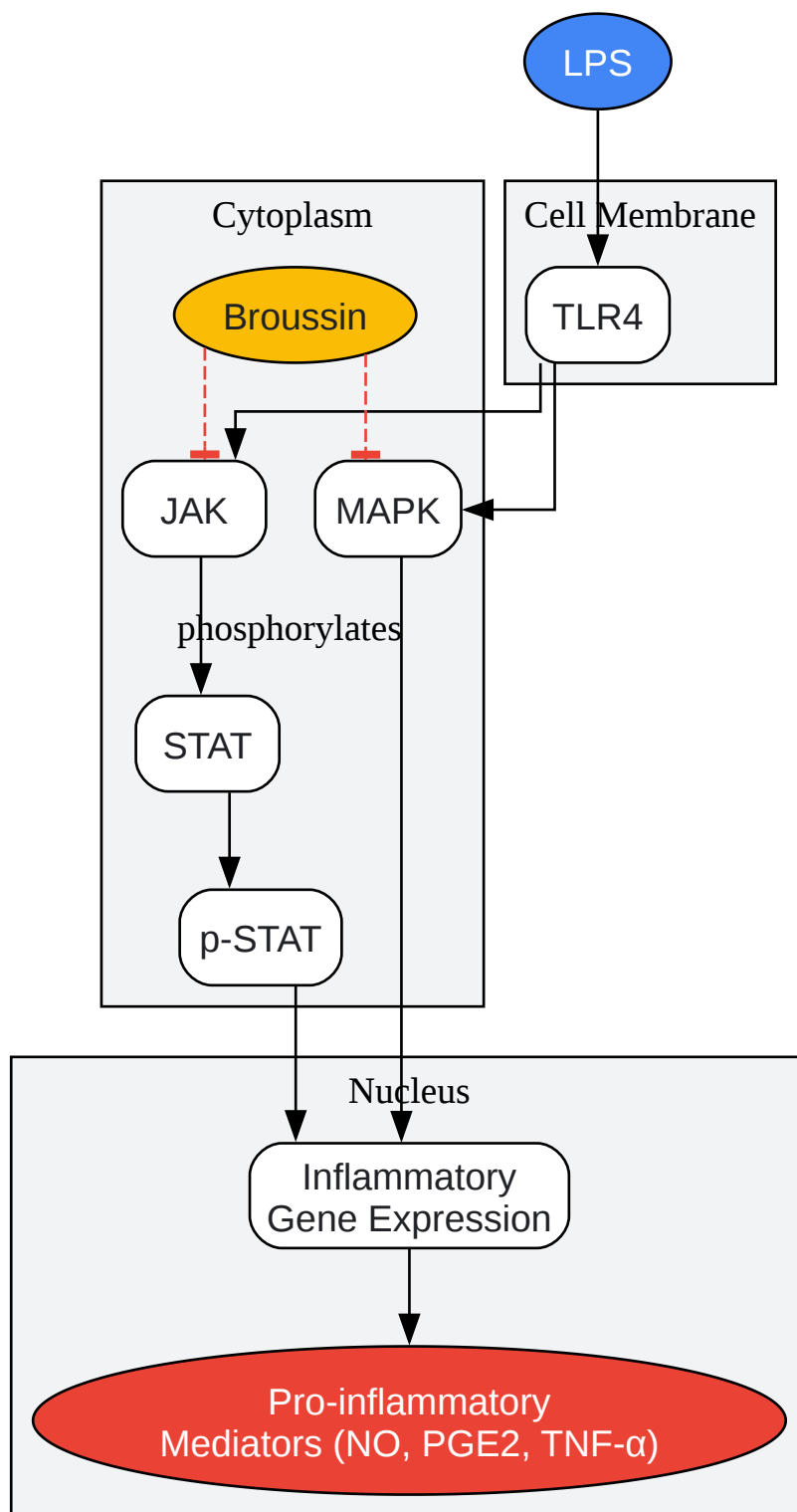

[Click to download full resolution via product page](#)

Caption: Hypothesized anti-inflammatory mechanism of **Broussin**.

PI3K-Akt Signaling Pathway Inhibition (Hypothesized)

In the context of cancer cell proliferation, flavonoids like morusin have been shown to inhibit the PI3K-Akt pathway.[6] **Broussin** may act similarly.

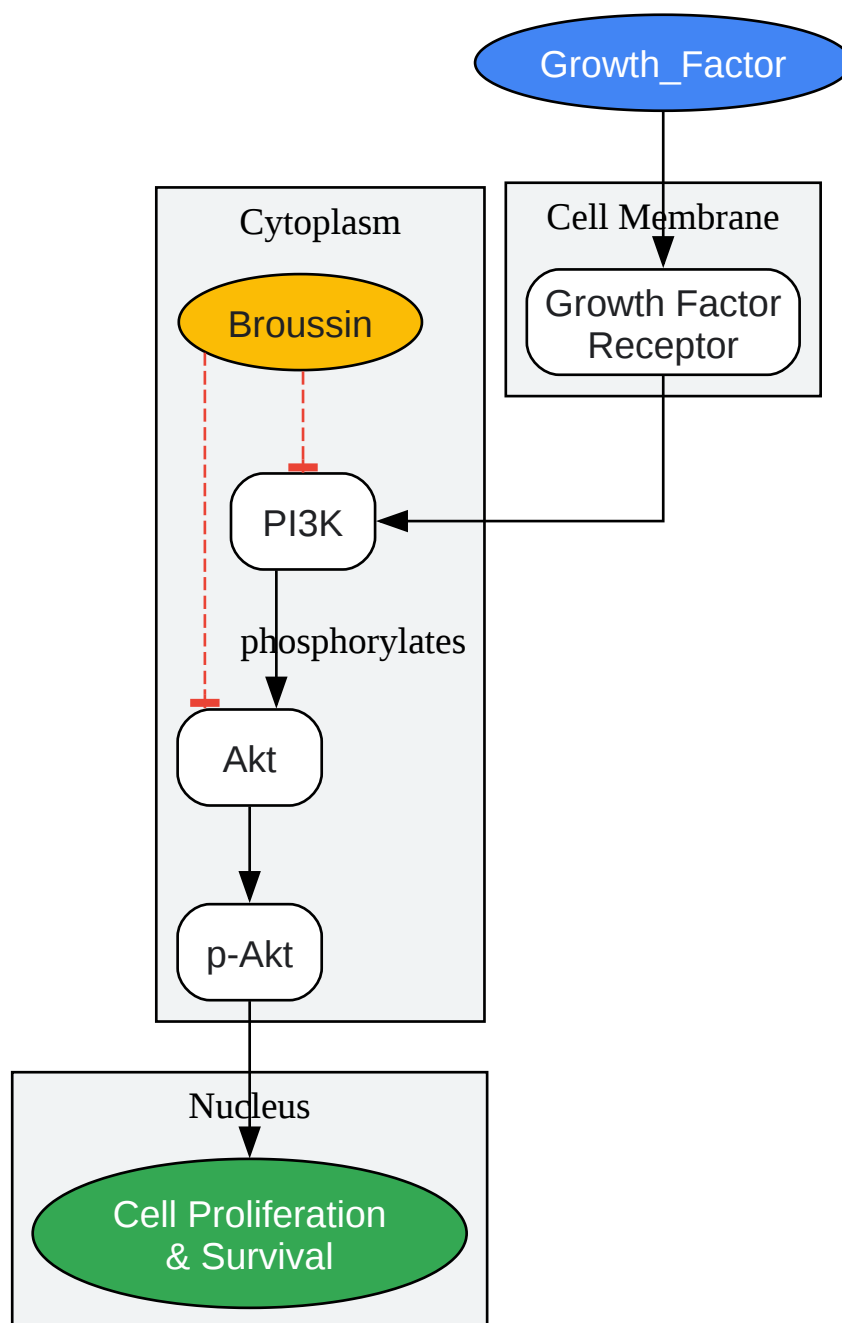

[Click to download full resolution via product page](#)

Caption: Hypothesized PI3K-Akt inhibition by **Broussin**.

Need Custom Synthesis?

BenchChem offers custom synthesis for rare earth carbides and specific isotopic labeling.

Email: info@benchchem.com or [Request Quote Online](#).

References

- 1. [mdpi.com](https://www.mdpi.com) [[mdpi.com](https://www.mdpi.com)]
- 2. Improvement strategies for the oral bioavailability of poorly water-soluble flavonoids: An overview - PubMed [pubmed.ncbi.nlm.nih.gov]
- 3. Topical anti-inflammatory activity of extracts and compounds from *Thymus broussonetii* - PubMed [pubmed.ncbi.nlm.nih.gov]
- 4. Chemistry and Biological Activities of Flavonoids: An Overview - PMC [pubmed.ncbi.nlm.nih.gov]
- 5. [benchchem.com](https://www.benchchem.com) [[benchchem.com](https://www.benchchem.com)]
- 6. Mechanism of morusin on breast cancer via network pharmacology and in vitro experiments - PMC [pubmed.ncbi.nlm.nih.gov]
- 7. Flavonoids as tyrosinase inhibitors in in silico and in vitro models: basic framework of SAR using a statistical modelling approach - PMC [pubmed.ncbi.nlm.nih.gov]
- 8. [activeconceptsllc.com](https://www.activeconceptsllc.com) [[activeconceptsllc.com](https://www.activeconceptsllc.com)]
- To cite this document: BenchChem. [Addressing inconsistent results in Broussin bioactivity assays]. BenchChem, [2026]. [Online PDF]. Available at: [<https://www.benchchem.com/product/b1208535/docs#addressing-inconsistent-results-in-broussin-bioactivity-assays>]

Disclaimer & Data Validity:

The information provided in this document is for Research Use Only (RUO) and is strictly not intended for diagnostic or therapeutic procedures. While BenchChem strives to provide accurate protocols, we make no warranties, express or implied, regarding the fitness of this product for every specific experimental setup.

Technical Support: The protocols provided are for reference purposes. Unsure if this reagent suits your experiment?

Need Industrial/Bulk Grade? [Request Custom Synthesis Quote](#)

BenchChem

Our mission is to be the trusted global source of essential and advanced chemicals, empowering scientists and researchers to drive progress in science and industry.

Contact

Address: 3281 E Guasti Rd
Ontario, CA 91761, United States
Phone: (601) 213-4426
Email: info@benchchem.com

[Contact our Ph.D. Support Team for a compatibility check](#)