

# A Comparative Performance Analysis: Thiophene-Based Polymers vs. Terephthalic Acid-Based Polymers

**Author:** BenchChem Technical Support Team. **Date:** March 2026

## Compound of Interest

Compound Name: *5-Aminothiophene-2,4-dicarboxylic acid*

Cat. No.: *B12067722*

[Get Quote](#)

## A Senior Application Scientist's Guide to Monomer Selection and Polymer Performance

In the quest for high-performance materials, the choice of monomeric building blocks is paramount. The geometry, aromaticity, and heteroatomic composition of a monomer dictate the final properties of the resulting polymer, influencing everything from thermal stability and mechanical strength to processability and specialized functionalities. This guide provides an in-depth comparison of polymers derived from two distinct dicarboxylic acid monomers: the heteroaromatic 2,5-thiophenedicarboxylic acid (TDCA) and the ubiquitous aromatic terephthalic acid (TPA).

A note on the selected monomer: Initial exploration for polymers derived from **5-Aminothiophene-2,4-dicarboxylic acid** revealed a scarcity of available research data. Therefore, to provide a meaningful and data-supported comparison, this guide focuses on the well-characterized and structurally relevant 2,5-thiophenedicarboxylic acid as a representative of thiophene-based monomers.

This analysis is designed for researchers, scientists, and drug development professionals seeking to understand the nuanced performance trade-offs when substituting a traditional benzene-based monomer with a thiophene-based analogue. We will delve into the synthesis, thermal and mechanical properties, and other key performance metrics, supported by experimental data and protocols.

# Monomer Structure and its Influence on Polymer Architecture

The fundamental difference between TDCA and TPA lies in the aromatic core: a five-membered sulfur-containing thiophene ring versus a six-membered benzene ring. This seemingly subtle change has profound implications for the polymer backbone.

- **Bond Angles and Chain Linearity:** Terephthalic acid's 1,4-substitution pattern on the benzene ring results in a highly linear and rigid polymer chain, as seen in Poly(ethylene terephthalate) (PET) and aramids like Kevlar. This linearity facilitates efficient chain packing and high crystallinity. The bond angles within the thiophene ring of TDCA lead to a slightly less linear geometry compared to the benzene ring.[1]
- **Polarity and Intermolecular Interactions:** The presence of the sulfur heteroatom in the thiophene ring introduces a dipole moment and increases the polarity of the monomer unit compared to the nonpolar benzene ring.[1] This can influence inter-chain interactions, solubility, and gas barrier properties.
- **Electronic Properties:** The thiophene ring is more electron-rich than the benzene ring, a property that is foundational to the use of polythiophenes in organic electronics.[2][3] While not the focus of this guide, this electronic difference can influence the polymer's stability and interactions.[3]

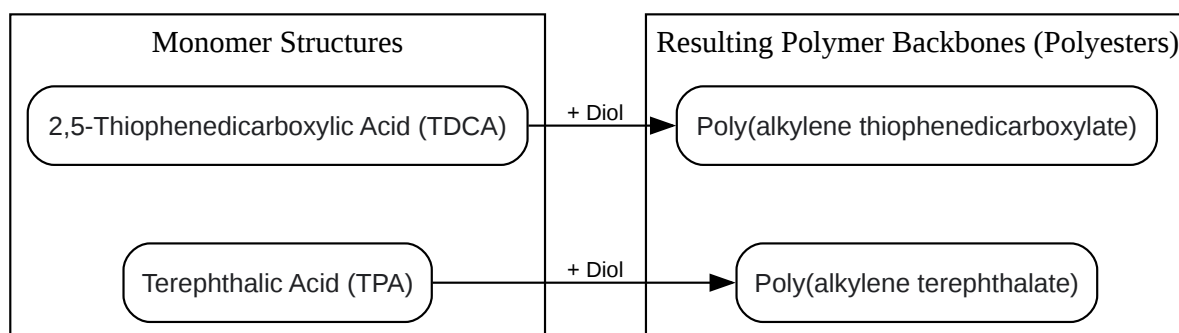

[Click to download full resolution via product page](#)

Caption: Monomer structures and their corresponding polyester backbones.

## Comparative Performance Data

The structural differences outlined above manifest in tangible performance variations. The following tables summarize key thermal and mechanical properties compiled from various studies.

### Table 1: Thermal Properties Comparison

Property	Thiophene-Based Polymers	Terephthalic Acid-Based Polymers	Key Insights & Causality
Decomposition Temp. (Td, 5% loss)	350 - 460 °C (Polyesters/Polyamides)[4][5]	380 - 500 °C (Polyamides/Polyesters)[5]	Thiophene-based polymers exhibit high thermal stability, often comparable to their benzene-ring counterparts.[5] The inherent stability of the aromatic and heteroaromatic rings contributes to high decomposition temperatures.
Glass Transition Temp. (Tg)	47 - 100 °C (Polyesters)[1]	70 - 275 °C (PET ~70°C, Aramids >270°C)[6]	The less linear structure of the thiophene unit can disrupt chain packing, leading to a lower Tg in some cases compared to highly rigid aramids. However, values are comparable to amorphous polyesters like PET.

### Table 2: Mechanical Properties Comparison

Property	Thiophene-Based Polymers	Terephthalic Acid-Based Polymers	Key Insights & Causality
Tensile Strength	6 - 80 MPa (Polyesters/Polyamides)[5][7]	50 - 3600 MPa (PET ~50 MPa, Kevlar ~3600 MPa)	While thiophene-based polymers can achieve high tensile strength, the exceptional strength of para-aramids like Kevlar is due to their perfectly linear chains and extensive hydrogen bonding, a benchmark that is difficult to match.
Young's Modulus	100 - 2500 MPa[5][7]	2000 - 131,000 MPa (PET ~2-4 GPa, Kevlar ~131 GPa)	The modulus is highly dependent on crystallinity and chain orientation. The rigidity of the thiophene ring provides good stiffness, but the ultra-high modulus of para-aramids is a direct result of their unique morphology.
Elongation at Break	>110% (for ductile polyesters)[8]	50-150% (PET), ~2.4% (Kevlar)	Thiophene-based polyesters can be engineered to be highly ductile, a desirable property for applications like packaging films.[7]

## Specialized Performance: Gas Barrier Properties

A notable advantage of incorporating thiophene units is the significant improvement in gas barrier properties. TDCA-based copolyesters demonstrate gas barrier attributes that can exceed those of commodity poly(butylene adipate-co-terephthalate) (PBAT) by over threefold and can be more than 500 times better in some formulations.<sup>[7][9]</sup> This enhanced performance is attributed to the polarity of the thiophene ring and potentially altered free volume and chain mobility, making these polymers highly attractive for advanced packaging applications.<sup>[7][9]</sup>

## Experimental Protocols

To ensure the trustworthiness and reproducibility of these findings, this section details the standardized methodologies for the synthesis and characterization of these polymers.

### A. Polymer Synthesis: Two-Stage Melt Polycondensation

This common, solvent-free method is used for producing high molecular weight polyesters from dicarboxylic acids (or their dimethyl esters) and diols.

Rationale: Melt polycondensation avoids the use of hazardous solvents and is scalable for industrial production. A two-stage process allows for initial esterification/transesterification at lower temperatures followed by a high-temperature, high-vacuum polycondensation step to effectively remove the condensation byproduct (e.g., water or methanol) and drive the reaction to completion, thereby achieving high molecular weight.<sup>[10][11]</sup>

Step-by-Step Protocol:

- **Charging the Reactor:** A glass reactor equipped with a mechanical stirrer, nitrogen inlet, and a distillation outlet is charged with the dicarboxylic acid (or its dimethyl ester, e.g., dimethyl 2,5-thiophenedicarboxylate) and a diol (e.g., 1,3-propanediol) in a specified molar ratio (typically 1:1.2 to 1:2 diol excess).<sup>[11]</sup>
- **Catalyst Addition:** A catalyst, such as antimony trioxide or a titanium-based catalyst (e.g., titanium(IV) isopropoxide), is added (typically in ppm concentrations).<sup>[10][11]</sup>
- **First Stage (Esterification/Transesterification):** The mixture is heated under a nitrogen atmosphere to a temperature of 180-220°C. The reaction is allowed to proceed for 2-4 hours while the byproduct (water or methanol) is distilled off.<sup>[10]</sup>



## B. Polymer Characterization

A suite of analytical techniques is required to create a comprehensive performance profile of the synthesized polymers.

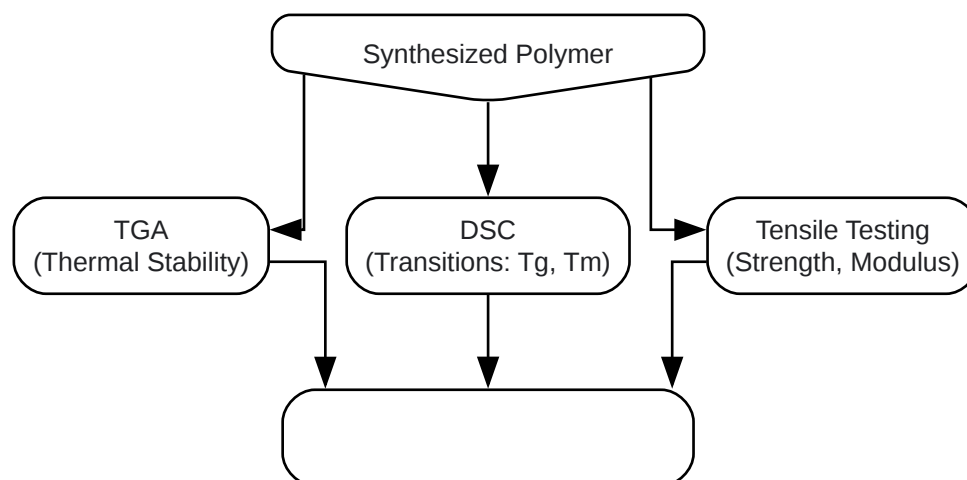

[Click to download full resolution via product page](#)

Caption: Experimental workflow for polymer characterization.

### 1. Thermogravimetric Analysis (TGA)

- Objective: To determine the thermal stability and decomposition temperature (Td) of the polymer.[1][12]
- Protocol:
  - Place a small, precisely weighed sample (5-10 mg) into a TGA sample pan.
  - Place the pan into the TGA furnace.
  - Heat the sample from ambient temperature to 600-800°C at a constant rate (e.g., 10°C/min) under a controlled atmosphere (typically nitrogen to prevent oxidative degradation).[13]
  - Record the sample weight as a function of temperature. The Td is often reported as the temperature at which 5% weight loss occurs.[13]

## 2. Differential Scanning Calorimetry (DSC)

- Objective: To identify thermal transitions such as the glass transition temperature ( $T_g$ ), melting temperature ( $T_m$ ), and crystallization temperature ( $T_c$ ).[\[1\]](#)[\[12\]](#)
- Protocol:
  - Seal a small, weighed sample (5-10 mg) in an aluminum DSC pan.
  - Place the sample pan and an empty reference pan into the DSC cell.
  - Perform a heat-cool-heat cycle. For example: heat from 25°C to 300°C at 10°C/min, hold for 2 minutes to erase thermal history, cool to 25°C at 10°C/min, and then reheat to 300°C at 10°C/min.
  - The  $T_g$  is identified as a step change in the heat flow curve from the second heating scan.  $T_m$  and  $T_c$  are identified as the peaks of endothermic and exothermic events, respectively. [\[13\]](#)

## 3. Tensile Testing

- Objective: To measure the mechanical properties of the polymer, including tensile strength, Young's modulus, and elongation at break, typically following ASTM D638 standards.[\[14\]](#)[\[15\]](#)
- Protocol:
  - Prepare test specimens by compression molding or solution casting the polymer into a standard shape (e.g., a "dogbone" shape).[\[14\]](#)
  - Condition the specimens under controlled temperature and humidity as required by the standard.
  - Mount the specimen into the grips of a universal testing machine.[\[16\]](#)
  - Apply a tensile load at a constant rate of crosshead movement until the specimen fractures.[\[15\]](#)

- Record the load and extension data throughout the test. Stress is calculated by dividing the load by the initial cross-sectional area, and strain is calculated by dividing the extension by the initial gauge length.[16]

## Conclusion and Future Outlook

The substitution of a traditional terephthalic acid monomer with a thiophene-based analogue like 2,5-thiophenedicarboxylic acid presents a compelling strategy for tuning polymer properties. While fully aromatic polyamides based on TPA remain the gold standard for ultimate thermal stability and mechanical strength, TDCA-based polymers offer a competitive profile with distinct advantages.

Key Takeaways:

- **Comparable Thermal Stability:** Thiophene-based polymers demonstrate high thermal stability, making them suitable for many high-performance applications.[5]
- **Tunable Mechanical Properties:** The mechanical properties of TDCA-polymers can be tailored, achieving both high strength and high ductility, depending on the choice of comonomers.[7][8]
- **Superior Gas Barrier:** The most significant advantage observed is the enhanced gas barrier performance, positioning these materials as strong candidates for advanced packaging and film applications.[7][9]
- **Bio-Based Potential:** TDCA is an emerging bio-based monomer, which aligns with the growing demand for sustainable materials.[4]

For researchers and developers, the choice between these monomers is not a matter of direct replacement but of strategic selection. If the goal is to achieve a balance of thermal and mechanical performance with the added benefit of superior barrier properties and a potential bio-based origin, polymers from 2,5-thiophenedicarboxylic acid offer a promising and innovative alternative to their terephthalic acid-based counterparts.

## References

- Patsnap Eureka. (2026, February 24). Benzene Ring vs Thiophene: Stability in Conductive Materials. [\[Link\]](#)
- University of Nottingham Ningbo China. (2024, October 15). An investigation into the synthesis, properties, and biodegradation characteristics of copolyesters derived from 2,5-thiophenedicarboxylic acid. [\[Link\]](#)
- ACS Publications. (2023, June 5). Synthesis and Structure–Property Relationships of Novel High Molecular Weight Fully Biobased 2,5-Thiophenedicarboxylic Acid-Based Polyesters | Biomacromolecules. [\[Link\]](#)
- National Center for Biotechnology Information (PMC). (2020, August 27). Effects of Thiophene and Benzene Ring Accumulation on the Photocatalytic Performance of Polymers. [\[Link\]](#)
- ACS Publications. (2020, August 27). Effects of Thiophene and Benzene Ring Accumulation on the Photocatalytic Performance of Polymers | ACS Omega. [\[Link\]](#)
- Terrific Science. (n.d.). 6 Simple Tensile Testing of Polymeric Films and Sheeting. [\[Link\]](#)
- MDPI. (n.d.). Synthesis of Biobased Soft-Packaging Polyesters from 2,5 Thiophenedicarboxylic Acid. [\[Link\]](#)
- ACS Publications. (2024, August 1). Biodegradable Copolyesters Derived from 2,5-Thiophenedicarboxylic Acid for High Gas Barrier Packaging Applications: Synthesis, Crystallization Properties, and Biodegradation Mechanisms | ACS Sustainable Chemistry & Engineering. [\[Link\]](#)
- Matmatch. (2026, January 5). Tensile Testing of Polymers: Understanding ASTM D638 for Plastic Material Testing. [\[Link\]](#)
- PubMed. (2023, December 11). Biobased Biodegradable Copolyesters from 2,5-Thiophenedicarboxylic Acid: Effect of Aliphatic Diols on Barrier Properties and Degradation. [\[Link\]](#)
- PubMed. (2020, August 27). Effects of Thiophene and Benzene Ring Accumulation on the Photocatalytic Performance of Polymers. [\[Link\]](#)

- MDPI. (2023, June 1). Effect of Controlling Thiophene Rings on D-A Polymer Photocatalysts Accessed via Direct Arylation for Hydrogen Production. [\[Link\]](#)
- SciSpace. (n.d.). Evaluation of tensile test for specific polymer. [\[Link\]](#)
- Michigan Technological University. (n.d.). Tensile Test Experiment. [\[Link\]](#)
- Shimadzu. (n.d.). Tensile Tests of Films. [\[Link\]](#)
- Google Patents. (n.d.). US2752328A - Polyamides of terephthalic acid and diamines having methyl substituted hydrocarbon chain.
- NPTEL Archive. (n.d.). The synthesis of PET requires two steps.... [\[Link\]](#)
- MDPI. (2021, July 27). Poly(Alkylene 2,5-Thiophenedicarboxylate) Polyesters: A New Class of Bio-Based High-Performance Polymers for Sustainable Packaging. [\[Link\]](#)
- Google Patents. (n.d.). US5118785A - Preparation of polyether amide from tetraethylene glycol diamine and terephthalic acid.
- ResearchGate. (n.d.). Synthesis and properties of polyamides from 2,5-furandicarboxylic acid: Research Article | Request PDF. [\[Link\]](#)
- Scribd. (n.d.). DSC and TGA: Thermal Analysis Methods | PDF. [\[Link\]](#)
- Advanced EMC Technologies. (2017, April 13). Thermal Analysis Techniques for Polymers, Part 2: DSC, TGA, EGA. [\[Link\]](#)
- ResearchGate. (n.d.). DSC and TGA curves of polyimide1-3. DSC: differential scanning calorimetry; TGA: thermogravimetric analysis. [\[Link\]](#)
- ResearchGate. (2025, December 4). Synthesis and characterization of bio-based polyesters from 2,5-thiophenedicarboxylic acid | Request PDF. [\[Link\]](#)
- ResearchGate. (2026, January 7). Synthesis of Thiophene-Based Polyamides. [\[Link\]](#)
- Polimery. (n.d.). Solid-state polycondensation (SSP) as a method to obtain high molecular weight polymers. [\[Link\]](#)

- EAG Laboratories. (n.d.). DSC Analysis of Polymers | Thermal. [[Link](#)]
- ResearchGate. (n.d.). The effect of diamine length on the direct solid state polycondensation of semi-aromatic nylon salts | Request PDF. [[Link](#)]
- ResearchGate. (n.d.). Thermal properties of polyamides 3a-3f and 3h | Download Table. [[Link](#)]
- ResolveMass Laboratories Inc. (2026, January 6). DSC vs TGA: A Simple Comparison Guide. [[Link](#)]
- Google Patents. (n.d.). CN1876645A - Thiophene-2,5-dicarboxylic acid synthesis method.

#### **Need Custom Synthesis?**

*BenchChem offers custom synthesis for rare earth carbides and specific isotopic labeling.*

*Email: [info@benchchem.com](mailto:info@benchchem.com) or [Request Quote Online](#).*

## Sources

- 1. [advanced-emc.com](https://advanced-emc.com) [[advanced-emc.com](https://advanced-emc.com)]
- 2. Benzene Ring vs Thiophene: Stability in Conductive Materials [[eureka.patsnap.com](https://eureka.patsnap.com)]
- 3. Effects of Thiophene and Benzene Ring Accumulation on the Photocatalytic Performance of Polymers - PMC [[pmc.ncbi.nlm.nih.gov](https://pubmed.ncbi.nlm.nih.gov)]
- 4. [pubs.acs.org](https://pubs.acs.org) [[pubs.acs.org](https://pubs.acs.org)]
- 5. [researchgate.net](https://researchgate.net) [[researchgate.net](https://researchgate.net)]
- 6. [eag.com](https://eag.com) [[eag.com](https://eag.com)]
- 7. An investigation into the synthesis, properties, and biodegradation characteristics of copolyesters derived from 2,5-thiophenedicarboxylic acid - University of Nottingham Ningbo China [[research.nottingham.edu.cn](https://research.nottingham.edu.cn)]
- 8. [researchgate.net](https://researchgate.net) [[researchgate.net](https://researchgate.net)]
- 9. [pubs.acs.org](https://pubs.acs.org) [[pubs.acs.org](https://pubs.acs.org)]
- 10. Silver formation [[archive.nptel.ac.in](https://archive.nptel.ac.in)]

- [11. Poly\(Alkylene 2,5-Thiophenedicarboxylate\) Polyesters: A New Class of Bio-Based High-Performance Polymers for Sustainable Packaging \[mdpi.com\]](#)
- [12. scribd.com \[scribd.com\]](#)
- [13. pdf.benchchem.com \[pdf.benchchem.com\]](#)
- [14. terrificscience.org \[terrificscience.org\]](#)
- [15. wrapfilmtest.com \[wrapfilmtest.com\]](#)
- [16. mtu.edu \[mtu.edu\]](#)
- To cite this document: BenchChem. [A Comparative Performance Analysis: Thiophene-Based Polymers vs. Terephthalic Acid-Based Polymers]. BenchChem, [2026]. [Online PDF]. Available at: [<https://www.benchchem.com/product/b12067722#performance-of-polymers-from-5-aminothiophene-2-4-dicarboxylic-acid-vs-terephthalic-acid>]

---

#### Disclaimer & Data Validity:

The information provided in this document is for Research Use Only (RUO) and is strictly not intended for diagnostic or therapeutic procedures. While BenchChem strives to provide accurate protocols, we make no warranties, express or implied, regarding the fitness of this product for every specific experimental setup.

**Technical Support:** The protocols provided are for reference purposes. Unsure if this reagent suits your experiment? [[Contact our Ph.D. Support Team for a compatibility check](#)]

**Need Industrial/Bulk Grade?** [Request Custom Synthesis Quote](#)

## BenchChem

Our mission is to be the trusted global source of essential and advanced chemicals, empowering scientists and researchers to drive progress in science and industry.

#### Contact

Address: 3281 E Guasti Rd

Ontario, CA 91761, United States

Phone: (601) 213-4426

Email: [info@benchchem.com](mailto:info@benchchem.com)