

Technical Support Center: Controlling for Off-Target Effects of EPAC Agonists

Author: BenchChem Technical Support Team. **Date:** April 2026

Compound of Interest

Compound Name: 8-MA-cAMP

Cat. No.: B12062424

[Get Quote](#)

This technical support center provides researchers, scientists, and drug development professionals with comprehensive guidance on controlling for the off-target effects of 8-methoxy-2'-O-methyladenosine-3',5'-cyclic monophosphate (**8-MA-cAMP**) and its widely used analog, 8-(4-chlorophenylthio)-2'-O-methyladenosine-3',5'-cyclic monophosphate (8-pCPT-2'-O-Me-cAMP). The information is presented in a question-and-answer format through FAQs and troubleshooting guides to address specific experimental issues.

Frequently Asked Questions (FAQs)

Q1: What is 8-pCPT-2'-O-Me-cAMP and what is its primary target?

A1: 8-pCPT-2'-O-Me-cAMP is a cell-permeable analog of cyclic adenosine monophosphate (cAMP). Its primary molecular target is the Exchange Protein directly Activated by cAMP (EPAC), a guanine nucleotide exchange factor for the small G proteins Rap1 and Rap2. It is designed to be a selective activator of EPAC, allowing researchers to study EPAC-specific signaling pathways independently of the other major cAMP sensor, Protein Kinase A (PKA).^[1]
^[2]

Q2: What are the known off-target effects of 8-pCPT-2'-O-Me-cAMP?

A2: The primary off-target effect of 8-pCPT-2'-O-Me-cAMP is the activation of Protein Kinase A (PKA), especially at higher concentrations.[3][4] While it is significantly more potent for EPAC, its selectivity is not absolute.[5] Additionally, some cAMP analogs, particularly their prodrug forms (e.g., those with an acetoxymethyl (AM) ester), have been reported to act as phosphodiesterase (PDE) inhibitors. PDE inhibition would lead to an accumulation of endogenous cAMP, which can activate both PKA and EPAC, complicating the interpretation of results.

Q3: How selective is 8-pCPT-2'-O-Me-cAMP for EPAC over PKA?

A3: 8-pCPT-2'-O-Me-cAMP displays strong selectivity for EPAC over PKA. However, this selectivity is concentration-dependent. At concentrations sufficient to maximally activate EPAC, there may be minimal PKA activation. It is crucial to perform a dose-response curve in your specific experimental system to determine the optimal concentration that activates EPAC without significantly engaging PKA.

Q4: My experimental results are inconsistent. Could off-target effects be the cause?

A4: Yes, inconsistent or unexpected results are often a sign of off-target effects. If the observed phenotype resembles known PKA-mediated effects or if the magnitude of the response is larger than expected, it is prudent to investigate potential PKA activation or PDE inhibition.

Troubleshooting Guides

Problem 1: Observed cellular response is not consistent with known EPAC signaling and may involve PKA.

- Possible Cause: The concentration of 8-pCPT-2'-O-Me-cAMP used is high enough to activate PKA.
- Solution:
 - Pharmacological Inhibition: Pre-incubate your cells with a PKA inhibitor before adding 8-pCPT-2'-O-Me-cAMP. If the effect is abolished or significantly reduced, it indicates PKA involvement.

- Direct PKA Activity Assay: Measure PKA activity in cell lysates treated with 8-pCPT-2'-O-Me-cAMP to directly assess its effect on PKA.
- Dose-Response Analysis: Perform a detailed dose-response curve for 8-pCPT-2'-O-Me-cAMP in your system and use the lowest effective concentration.
- Use a Negative Control: If available, use a structurally related but inactive analog of 8-pCPT-2'-O-Me-cAMP.

Problem 2: The observed effect of 8-pCPT-2'-O-Me-cAMP is unexpectedly potent or widespread, suggesting an increase in total intracellular cAMP.

- Possible Cause: 8-pCPT-2'-O-Me-cAMP or its metabolites may be inhibiting phosphodiesterases (PDEs), leading to an accumulation of endogenous cAMP.
- Solution:
 - Measure Intracellular cAMP: Directly measure intracellular cAMP levels in response to 8-pCPT-2'-O-Me-cAMP treatment using a sensitive method like an ELISA. A significant increase in total cAMP would suggest PDE inhibition.
 - Use a General PDE Inhibitor: As a positive control, treat cells with a broad-spectrum PDE inhibitor like IBMX. If the effect of 8-pCPT-2'-O-Me-cAMP mimics that of IBMX, it may indicate a similar mechanism of action.

Quantitative Data Summary

Table 1: Activator Potency on EPAC vs. PKA

Compound	Target	EC50 / AC50	Reference
8-pCPT-2'-O-Me-cAMP	EPAC1	~1.8-2.2 μ M	
8-pCPT-2'-O-Me-cAMP	PKA	> 10 μ M (weak activator)	
cAMP	EPAC1	~30 μ M	

Table 2: Commonly Used Pharmacological Controls

Inhibitor	Primary Target(s)	Typical Working Concentration	Key Considerations	Reference
H-89	PKA	5-20 μ M	Can have off-target effects on other kinases at higher concentrations.	
Rp-cAMPS	PKA	10-100 μ M	Competitive antagonist at cAMP binding sites on PKA regulatory subunits.	
ESI-09	EPAC1 / EPAC2	5-25 μ M	A non-cAMP analog inhibitor of EPAC activity.	

Experimental Protocols

Protocol 1: Control for PKA-Mediated Off-Target Effects Using a PKA Inhibitor (H-89)

- **Cell Preparation:** Plate cells at the desired density and allow them to adhere and reach the appropriate confluency.
- **Inhibitor Preparation:** Prepare a stock solution of H-89 in DMSO. The final DMSO concentration in the culture medium should be kept below 0.1%.
- **Pre-incubation:** Pre-treat the cells with 10 μ M H-89 for 1-2 hours in serum-free or appropriate culture medium. Include a vehicle control (DMSO only) group.
- **Stimulation:** Add 8-pCPT-2'-O-Me-cAMP to the desired final concentration to both the H-89-treated and vehicle-treated wells.
- **Incubation:** Incubate for the time period determined to be optimal for your experimental endpoint.
- **Assay:** Perform your downstream assay (e.g., western blot for a phosphorylation target, gene expression analysis, etc.).
- **Analysis:** Compare the results from the 8-pCPT-2'-O-Me-cAMP + vehicle group with the 8-pCPT-2'-O-Me-cAMP + H-89 group. A significant reduction in the response in the presence of H-89 indicates a PKA-dependent off-target effect.

Protocol 2: Direct Measurement of Intracellular cAMP Levels via ELISA

This protocol is a general guideline; refer to the manufacturer's instructions for your specific ELISA kit.

- **Cell Culture and Treatment:** Plate cells in multi-well plates. Once ready, replace the medium with serum-free medium and incubate with various concentrations of 8-pCPT-2'-O-Me-cAMP for the desired time. Include positive (e.g., Forskolin + IBMX) and negative (vehicle) controls.
- **Cell Lysis:** Aspirate the medium and lyse the cells using the lysis buffer provided in the kit (often 0.1 M HCl) to stop PDE activity.
- **Sample Preparation:** If your kit requires it, acetylate the samples and standards to increase the sensitivity of the assay.

- ELISA Procedure:
 - Add standards and samples to the wells of the goat anti-rabbit IgG-coated plate.
 - Add the cAMP-alkaline phosphatase conjugate and the rabbit anti-cAMP antibody.
 - Incubate at room temperature, typically for 2 hours.
 - Wash the plate multiple times to remove unbound reagents.
 - Add the pNpp substrate and incubate until a yellow color develops.
 - Stop the reaction with the provided stop solution.
- Data Acquisition: Read the absorbance at 405 nm using a microplate reader.
- Analysis: Calculate the cAMP concentration in your samples based on the standard curve. The amount of color is inversely proportional to the cAMP concentration.

Protocol 3: PKA Activity Assay in Cell Lysates

This is a generalized protocol; always follow the specific instructions of your chosen kinase activity assay kit.

- Cell Lysis: After treating cells with 8-pCPT-2'-O-Me-cAMP, wash them with ice-cold PBS and lyse them in a non-denaturing lysis buffer containing protease and phosphatase inhibitors.
- Protein Quantification: Determine the total protein concentration of each lysate to ensure equal loading in the assay.
- Kinase Reaction:
 - Add a defined amount of cell lysate to wells of a microtiter plate pre-coated with a specific PKA substrate.
 - Initiate the phosphorylation reaction by adding ATP.
 - Incubate at 30°C for 60-90 minutes.

- Detection:
 - Wash the wells to remove the cell lysate and ATP.
 - Add a phospho-specific primary antibody that recognizes the phosphorylated PKA substrate. Incubate for 1 hour at room temperature.
 - Wash, then add an HRP-conjugated secondary antibody. Incubate for 30-60 minutes.
 - Wash, then add a chromogenic substrate (like TMB).
- Data Acquisition: Stop the reaction and measure the absorbance at 450 nm.
- Analysis: The absorbance is directly proportional to the PKA activity in the sample. Compare the activity in treated versus untreated cells.

Visualizations

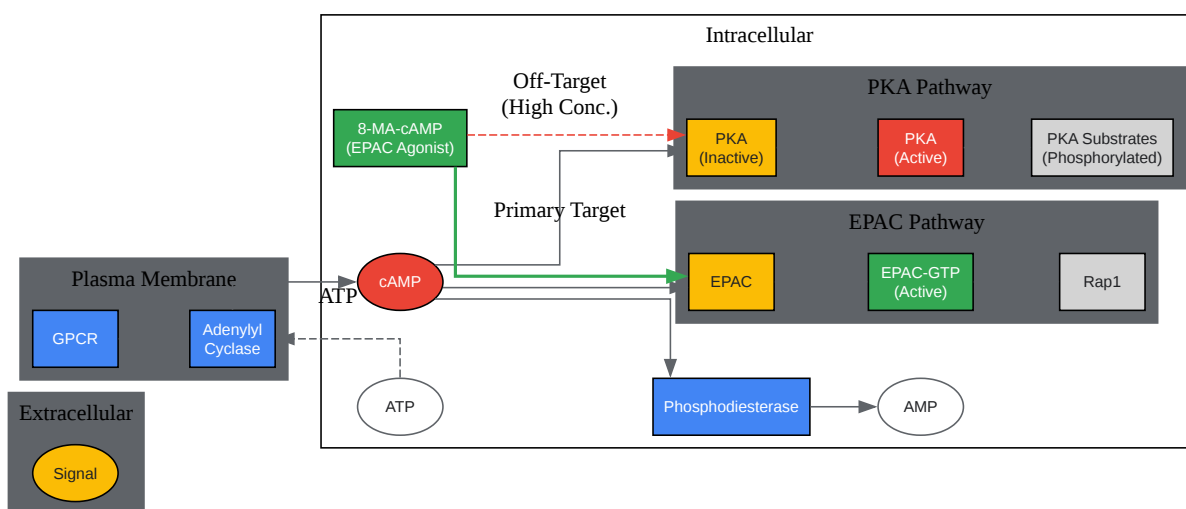

[Click to download full resolution via product page](#)

Figure 1: Simplified cAMP signaling pathways. This diagram illustrates how endogenous cAMP activates both PKA and EPAC. The EPAC agonist **8-MA-cAMP** is shown selectively activating EPAC at low concentrations, with potential off-target activation of PKA at higher concentrations.

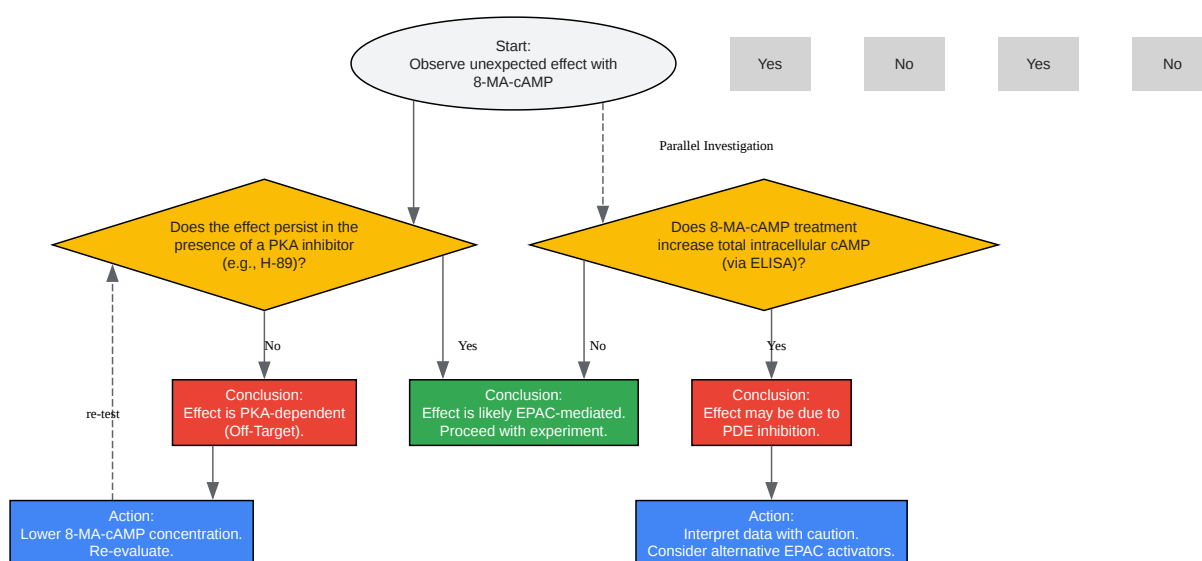

[Click to download full resolution via product page](#)

Figure 2: Experimental workflow for troubleshooting off-target effects. This decision tree guides researchers through a logical sequence of control experiments to determine if an observed effect of an EPAC agonist is on-target or due to PKA activation or PDE inhibition.

Need Custom Synthesis?

BenchChem offers custom synthesis for rare earth carbides and specific isotopic labeling.

Email: info@benchchem.com or [Request Quote Online](#).

References

- [1. Measurement of Intracellular cAMP Levels Using the Cyclic Nucleotide XP Enzymatic Immunoassay Kit in Bacteria \[en.bio-protocol.org\]](#)
- [2. Epac and PKA: a tale of two intracellular cAMP receptors - PMC \[pmc.ncbi.nlm.nih.gov\]](#)
- [3. Measurement of Intracellular cAMP Levels Using the Cyclic Nucleotide XP Enzymatic Immunoassay Kit in Bacteria \[bio-protocol.org\]](#)
- [4. abcam.com \[abcam.com\]](#)
- [5. search.cosmobio.co.jp \[search.cosmobio.co.jp\]](#)
- To cite this document: BenchChem. [Technical Support Center: Controlling for Off-Target Effects of EPAC Agonists]. BenchChem, [2026]. [Online PDF]. Available at: [\[https://www.benchchem.com/product/b12062424/docs#technical-support-center-controlling-for-off-target-effects-of-epac-agonists\]](https://www.benchchem.com/product/b12062424/docs#technical-support-center-controlling-for-off-target-effects-of-epac-agonists)

Disclaimer & Data Validity:

The information provided in this document is for Research Use Only (RUO) and is strictly not intended for diagnostic or therapeutic procedures. While BenchChem strives to provide accurate protocols, we make no warranties, express or implied, regarding the fitness of this product for every specific experimental setup.

Technical Support: The protocols provided are for reference purposes. Unsure if this reagent suits your experiment?

Need Industrial/Bulk Grade? [Request Custom Synthesis Quote](#)

BenchChem

Our mission is to be the trusted global source of essential and advanced chemicals, empowering scientists and researchers to drive progress in science and industry.

Contact

Address: 3281 E Guasti Rd
Ontario, CA 91761, United States
Phone: (601) 213-4426
Email: info@benchchem.com

Contact our Ph.D. Support Team for a compatibility check