

# Tempone-15N,D16 vs. Standard Nitroxide Labels: A Technical Comparison Guide

**Author:** BenchChem Technical Support Team. **Date:** May 2026

## Compound of Interest

Compound Name: Tempone 15N,D16

Cat. No.: B12061225

[Get Quote](#)

## Executive Summary

Tempone-15N,D16 (4-oxo-2,2,6,6-tetramethylpiperidine-1-oxyl-15N-d16) is the "high-definition" equivalent of standard spin labels. By replacing the natural

N isotope ( $I=1$ ) with

N ( $I=1/2$ ) and perdeuterating the molecule (replacing protons with deuterium), this probe eliminates the major sources of inhomogeneous line broadening.

**Primary Advantage:** It yields Electron Spin Resonance (ESR/EPR) spectra with ultra-narrow linewidths and a simplified doublet hyperfine structure. This allows for the resolution of subtle spectral shifts caused by membrane partitioning, polarity gradients, and microviscosity changes that are often obscured by the broad triplet lines of standard

N-H labels.

## Technical Deep Dive: The Physics of Resolution

To understand the superiority of Tempone-15N,D16, we must analyze the nuclear-electron interactions that dictate spectral quality.

## The Isotope Effect

- Standard Labels (

N,

H): The unpaired electron couples with the

N nucleus (Spin

), splitting the signal into 3 lines (Triplet). Furthermore, the 12 methyl protons couple weakly with the electron, creating "superhyperfine" splitting that manifests as significant inhomogeneous line broadening (~1–2 Gauss).

- Tempone-<sup>15</sup>N,<sup>2</sup>H<sub>16</sub> (

N,

H):

- N Substitution: The electron couples with

N (Spin

), splitting the signal into 2 lines (Doublet). This concentrates the total signal intensity into fewer lines, instantly boosting sensitivity.

- Perdeuteration (

H): The magnetic moment of deuterium is roughly 1/6th that of a proton. This collapses the superhyperfine broadening, resulting in extremely sharp lines (linewidths

0.1–0.2 Gauss).

## The Sensitivity Gain

Because the integrated area of an ESR absorption signal is constant for a given number of spins, \*\*narrowing the linewidth ( $\Delta H$

A

$A \propto 1/\Delta H^2$ ).

- Result: Tempone-15N,D16 offers a ~10-fold increase in signal-to-noise ratio (SNR) compared to its non-deuterated

N counterpart at the same concentration.

## Product Performance Comparison

The following table contrasts Tempone-15N,D16 with common alternatives used in membrane research.

### Table 1: Comparative Specifications of Membrane Spin Labels

Feature	Tempone-15N,D16	Tempone (Standard)	TEMPO	5-DSA / 16-DSA
Isotopes	N, Deuterium (H)	N, Hydrogen (H)	N, Hydrogen (H)	N, Hydrogen (H)
Spectral Lines	Doublet (2 lines)	Triplet (3 lines)	Triplet (3 lines)	Triplet (3 lines)
Linewidth ( )	~0.15 – 0.25 G	~1.0 – 1.5 G	~1.0 – 1.5 G	Broad / Anisotropic
Resolution	Ultra-High (Resolves water vs. lipid peaks)	Moderate (Peaks often overlap)	Moderate	Low (Immobilized)
Primary Use	Precise Partition Coefficients, Polarity Profiles, Hydration	General Partitioning, Volume Studies	Phase Transitions, Fluidity	Depth-dependent Fluidity (Anchored)
Membrane Loc.	Partitions (Water/Lipid Interface)	Partitions (Water/Lipid Interface)	Partitions (Hydrophobic core bias)	Fixed Depth (C5 or C16)

## Key Applications in Membrane Studies

## Precise Measurement of Partition Coefficients

In a membrane suspension, a soluble spin label exists in two populations: aqueous and membrane-bound. These environments have different polarities, causing a shift in the g-factor and hyperfine coupling (

).[1]

- With Standard Labels: The broad lines of the two populations overlap heavily, requiring complex computer subtraction to estimate the ratio.
- With Tempone-15N,D16: The lines are so narrow that the aqueous and lipid signals are often fully resolved on the magnetic field axis. You can directly integrate the peaks to calculate the partition coefficient ( ) with high accuracy.

## Transmembrane Polarity & Hydration Profiles

The hyperfine coupling constant (

) is linearly dependent on the dielectric constant (polarity) of the solvent.

- Mechanism: Tempone-15N,D16 allows researchers to measure minute shifts in as the probe enters the membrane. This provides a "molecular ruler" for water penetration into the lipid bilayer, critical for studying the effects of cholesterol, peptides, or drugs on membrane barrier functions.

## Experimental Protocol: Measuring Membrane Partitioning

Objective: Determine the lipid/water partition coefficient (

) of a liposomal system using Tempone-15N,D16.

### Phase 1: Sample Preparation

- Liposome Formation: Prepare Large Unilamellar Vesicles (LUVs) (e.g., POPC or DPPC) via extrusion (100 nm pore size) in PBS buffer (pH 7.4).
  - Note: Avoid buffers with high dielectric loss if using a standard cavity, or use a flat cell.
- Probe Addition: Add Tempone-15N,D16 to the liposome suspension.
  - Target Concentration: 50–100  $\mu$ M final concentration.
  - Critical: Keep concentration low to avoid Heisenberg spin exchange broadening, which would negate the high-resolution advantage.

## Phase 2: ESR Acquisition (X-Band)

- Load Sample: Transfer ~50  $\mu$ L into a gas-permeable TPX capillary (to control oxygen broadening) or a standard glass capillary if sealing is ensured.
- Instrument Parameters:
  - Microwave Power: 1–2 mW (Do not saturate; 15N/D labels saturate easier than 14N labels).
  - Modulation Amplitude: 0.05 – 0.1 Gauss.
    - Why? The modulation amplitude must be smaller than the intrinsic linewidth (<0.2 G) to avoid artificial broadening. Standard settings (1 G) will destroy the resolution.
  - Sweep Width: 40–50 Gauss.
  - Time Constant: 20–40 ms.

## Phase 3: Data Analysis

- Spectral Inspection: You will observe a "doublet of doublets" (or overlapping doublets).

- High Field Line: Look at the high-field N line. You should see two distinct components:
  - Peak A (Sharp, Higher amplitude): Free signal in bulk water (G).
  - Peak B (Shifted, Broader): Membrane-bound signal (G, depending on lipid depth).
- Calculation:

Where

is the double-integrated intensity of the respective peaks.

## Visualizing the Advantage

### Diagram 1: Spectral Resolution Mechanics

This diagram illustrates why the  $^{15}\text{N}$ , D16 isotope labeling is superior for detecting coexisting populations (Water vs. Lipid).

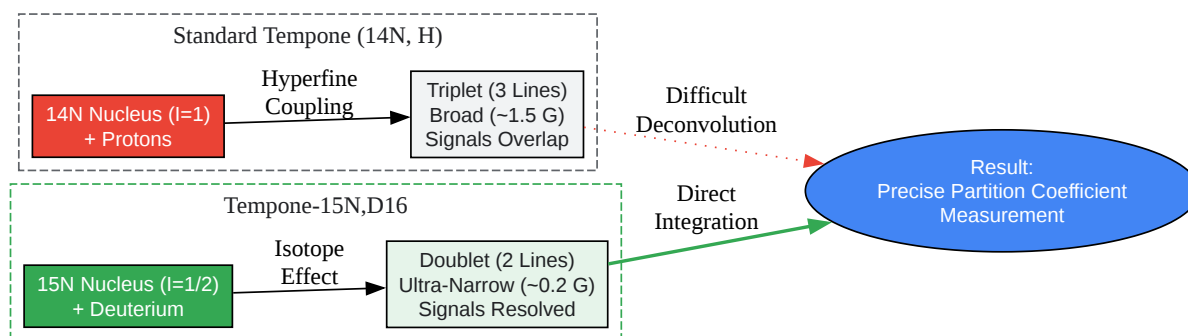

[Click to download full resolution via product page](#)

Caption: Comparison of spectral topology. The  $^{15}\text{N}$ -D16 substitution reduces line multiplicity and width, enabling direct resolution of membrane-bound vs. aqueous signals.

## Diagram 2: Experimental Workflow

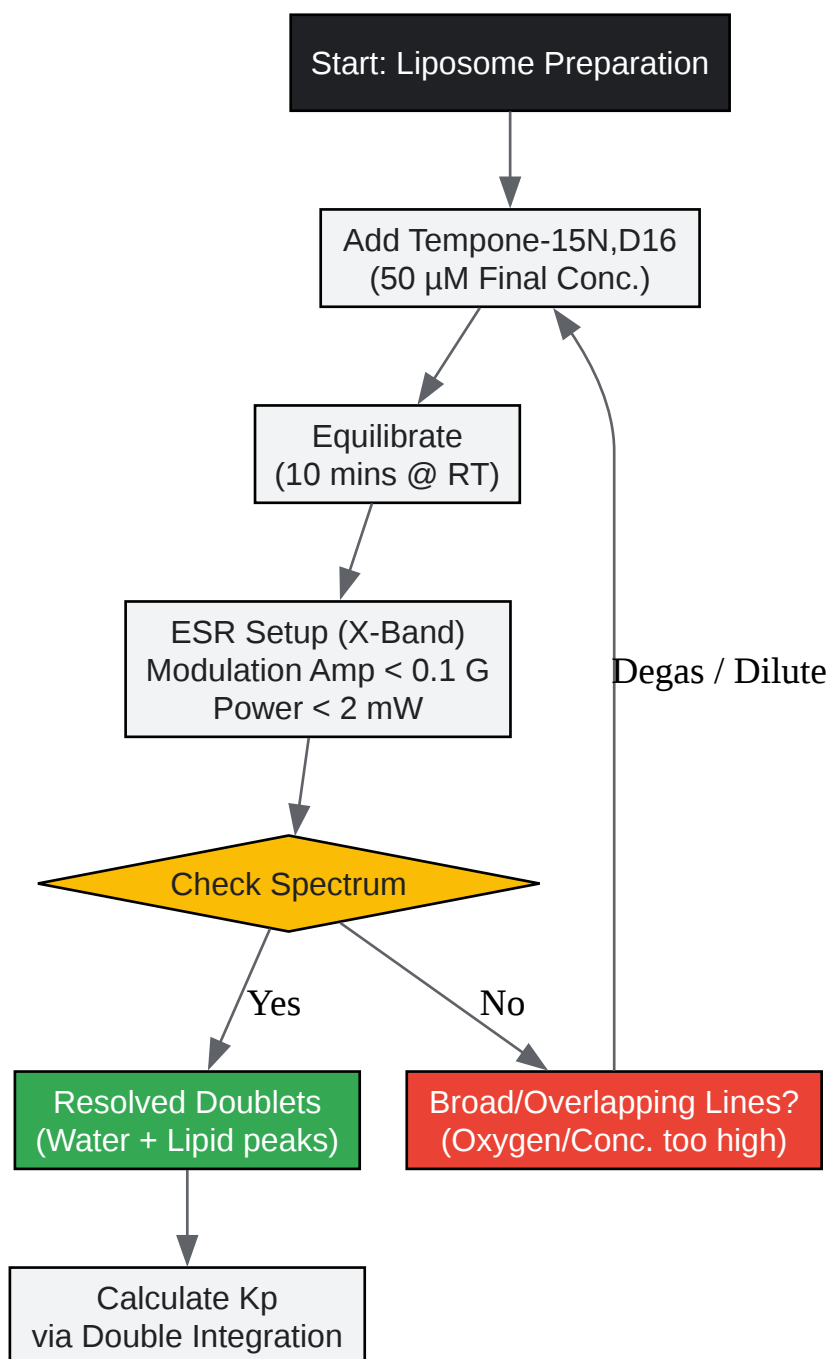

[Click to download full resolution via product page](#)

Caption: Step-by-step workflow for acquiring high-resolution partition data using Tempone-<sup>15</sup>N,<sup>2</sup>H<sub>16</sub>.

## References

- Marsh, D. (2019). Spin-Label Electron Paramagnetic Resonance Spectroscopy. CRC Press. (Authoritative text on spin label theory and linewidths).
- Hubbell, W. L., & McConnell, H. M. (1969).[2] Orientation and motion of amphiphilic spin labels in membranes. Proceedings of the National Academy of Sciences, 64(1), 20–27.[2] [Link\[2\]](#)
- Sahu, I. D., & Lorigan, G. A. (2021). <sup>15</sup>N- and <sup>2</sup>H-substituted maleimide spin labels: improved sensitivity and resolution for biological EPR studies. BioMed Research International.
- Kurad, D., et al. (2003). Determination of a transmembrane pH difference in chloroplasts with a spin label tempamine. Biochimica et Biophysica Acta (BBA). (Contextualizes the use of soluble spin labels for transmembrane gradients). [Link](#)
- Barnes, J. P., et al. (2009). Spin-Label EPR for Determining Polarity and Proticity in Biomolecular Assemblies.[1][3] Biological Magnetic Resonance. (Review of polarity profiles using Tempone).

### Need Custom Synthesis?

BenchChem offers custom synthesis for rare earth carbides and specific isotopic labeling.

Email: [info@benchchem.com](mailto:info@benchchem.com) or [Request Quote Online](#).

## Sources

- 1. Spin-Label EPR for Determining Polarity and Proticity in Biomolecular Assemblies: Transmembrane Profiles - PMC [[pmc.ncbi.nlm.nih.gov](https://pubmed.ncbi.nlm.nih.gov/)]
- 2. Electron Spin Resonance Analysis of the Nitroxide Spin Label 2,2,6,6-Tetramethylpiperidone-N-Oxyl (Tempone) in Single Crystals of the Reduced Tempone Matrix - PMC [[pmc.ncbi.nlm.nih.gov](https://pubmed.ncbi.nlm.nih.gov/)]
- 3. Lipid Membrane Polarity Profiles by High-Field EPR - PMC [[pmc.ncbi.nlm.nih.gov](https://pubmed.ncbi.nlm.nih.gov/)]

- To cite this document: BenchChem. [Tempone-15N,D16 vs. Standard Nitroxide Labels: A Technical Comparison Guide]. BenchChem, [2026]. [Online PDF]. Available at: [<https://www.benchchem.com/product/b12061225/docs#tempone-15n-d16-vs-standard-nitroxide-labels-a-technical-comparison-guide>]

---

### Disclaimer & Data Validity:

The information provided in this document is for Research Use Only (RUO) and is strictly not intended for diagnostic or therapeutic procedures. While BenchChem strives to provide accurate protocols, we make no warranties, express or implied, regarding the fitness of this product for every specific experimental setup.

**Technical Support:** The protocols provided are for reference purposes. Unsure if this reagent suits your experiment?

**Need Industrial/Bulk Grade?** [Request Custom Synthesis Quote](#)

## BenchChem

Our mission is to be the trusted global source of essential and advanced chemicals, empowering scientists and researchers to drive progress in science and industry.

### Contact

Address: 3281 E Guasti Rd  
Ontario, CA 91761, United States  
Phone: (601) 213-4426  
Email: [info@benchchem.com](mailto:info@benchchem.com)

[Contact our Ph.D. Support Team for a compatibility check](#)