

Application Notes and Protocols: Microwave-Enhanced Electrochemical Processes Using *t*-Butylferrocene

Author: BenchChem Technical Support Team. **Date:** April 2026

Compound of Interest

Compound Name: *t*-Butylferrocene

Cat. No.: B12061254

[Get Quote](#)

For Researchers, Scientists, and Drug Development Professionals

This document provides detailed application notes and protocols for utilizing ***t*-Butylferrocene** in microwave-enhanced electrochemical processes. The application of microwave irradiation to electrochemical systems can lead to significant enhancements in reaction rates and current responses, offering novel avenues for synthesis, analysis, and mechanistic studies relevant to drug development and other chemical sciences.

Introduction

Microwave-assisted chemistry has emerged as a powerful tool for accelerating chemical reactions, offering advantages such as rapid and uniform heating, which can lead to higher yields and shorter reaction times.[1][2][3] When applied to electrochemistry, microwave radiation can induce significant thermal and convection effects, enhancing mass transport of electroactive species to the electrode surface.[4] This can result in a considerable amplification of Faradaic currents, a phenomenon particularly beneficial for processes limited by mass transport.[5]

t-Butylferrocene, a derivative of ferrocene, is an organometallic compound widely used in non-aqueous electrochemistry.[6] Its stable and well-defined one-electron redox behavior makes it an excellent redox mediator, facilitating electron transfer in systems with slow kinetics.[6] The electron-donating t-butyl group modifies the electronic properties of the ferrocene core, resulting in a less positive redox potential compared to unsubstituted ferrocene.[6] In the context of microwave-enhanced electrochemistry, **t-Butylferrocene** can be employed as a robust redox probe and mediator, with its response being significantly enhanced by the application of microwave energy, especially in micellar media.[4][7]

These application notes will detail the principles, experimental setup, and protocols for leveraging the synergistic effects of microwave irradiation and the electrochemical properties of **t-Butylferrocene**.

Principles and Advantages

The enhancement of electrochemical processes by microwave radiation stems from two primary effects:

- **Thermal Effects:** Microwave energy is efficiently absorbed by polar molecules, leading to rapid and uniform heating of the bulk solution.[8] This increase in temperature enhances the kinetics of both the electrochemical reaction at the electrode surface and any coupled chemical reactions. It also increases the diffusion coefficients of electroactive species.
- **Non-Thermal Effects (Specific Microwave Effects):** While still a subject of some debate, non-thermal effects are proposed to arise from the direct interaction of the high-frequency electromagnetic field with molecules and ions in the solution.[8][9] These effects can include increased molecular rotation and ion mobility, contributing to enhanced mass transport beyond what is expected from thermal effects alone. In the context of electrochemistry, this can lead to a significant increase in current densities.[1]

Advantages of Microwave-Enhanced Electrochemistry with **t-Butylferrocene**:

- **Increased Sensitivity:** The enhancement of current responses allows for the detection of lower concentrations of analytes.[4]
- **Faster Analysis:** Accelerated reaction rates can significantly reduce the time required for electrochemical analysis and synthesis.[2]

- **Enhanced Reaction Rates:** For electro-organic synthesis, the combination of electrochemical activation and microwave heating can lead to dramatically increased reaction rates and product yields.
- **Improved Mass Transport:** Microwave-induced convection and heating effectively stir the solution at the microscale, overcoming diffusion limitations.[4]
- **Selective Heating:** In heterogeneous systems, microwaves can selectively heat specific components with higher dielectric loss tangents, potentially leading to novel reaction pathways.[8]

Experimental Setup

A specialized setup is required to perform electrochemical experiments under microwave irradiation safely and effectively. The core components include a microwave cavity, an electrochemical cell transparent to microwaves, and the standard electrochemical instrumentation (potentiostat, electrodes).

Key Components:

- **Microwave Reactor:** A single-mode microwave cavity is often preferred for laboratory-scale experiments as it allows for precise positioning of the electrochemical cell in a region of maximum electric or magnetic field.[4]
- **Electrochemical Cell:** The cell must be constructed from a microwave-transparent material, such as quartz or Teflon.[4] It should be designed to accommodate a three-electrode system (working, reference, and counter electrodes).
- **Electrodes:** Standard electrodes (e.g., glassy carbon, platinum, gold as working electrodes, Ag/AgCl or a quasi-reference electrode, and a platinum wire as the counter electrode) can be used. The leads of the electrodes should be shielded to prevent them from acting as antennas.
- **Temperature Monitoring:** A fiber-optic thermometer is essential for accurate temperature measurement, as traditional thermometers with metallic components would interfere with the microwave field.[4]

- Potentiostat: A standard potentiostat is used to control and measure the potential and current. It should be placed outside the microwave cavity and connected to the electrodes via shielded cables.

Below is a diagram illustrating the general experimental workflow for a microwave-enhanced electrochemical experiment.

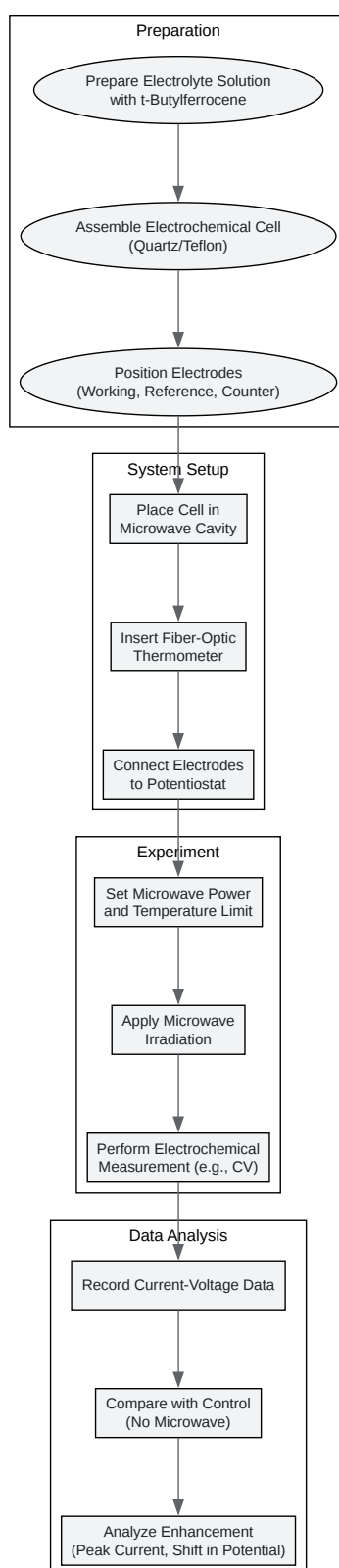

[Click to download full resolution via product page](#)

Diagram 1: Experimental workflow for microwave-enhanced electrochemistry.

Protocols

Protocol 1: Cyclic Voltammetry of **t-Butylferrocene** with Microwave Enhancement

Objective: To demonstrate the enhancement of the electrochemical response of **t-Butylferrocene** under microwave irradiation.

Materials:

- **t-Butylferrocene**
- Supporting Electrolyte (e.g., 0.1 M Tetrabutylammonium hexafluorophosphate, TBAPF₆)
- Solvent (e.g., Acetonitrile, high purity)
- Microwave-transparent electrochemical cell (e.g., quartz)
- Working Electrode (e.g., 3 mm Glassy Carbon Electrode)
- Reference Electrode (e.g., Ag/AgCl or a silver wire quasi-reference)
- Counter Electrode (e.g., Platinum wire)
- Potentiostat
- Single-mode microwave reactor
- Fiber-optic thermometer
- Polishing materials for the working electrode (e.g., alumina slurries)

Procedure:

- **Solution Preparation:** Prepare a 1 mM solution of **t-Butylferrocene** in acetonitrile containing 0.1 M TBAPF₆.
- **Electrode Preparation:** Polish the glassy carbon working electrode with alumina slurry, rinse thoroughly with deionized water and then the solvent, and dry it.

- Cell Assembly: Assemble the three-electrode system in the quartz electrochemical cell. Fill the cell with the prepared **t-Butylferrocene** solution.
- Control Experiment (No Microwave):
 - Place the cell in the microwave cavity but do not apply power.
 - Connect the electrodes to the potentiostat.
 - Record a cyclic voltammogram (CV) at a scan rate of 100 mV/s. The potential window should be set to scan through the Fe(II)/Fe(III) redox couple of **t-Butylferrocene** (e.g., from 0 V to +0.8 V vs. Ag/AgCl).
 - Record the peak currents (anodic and cathodic) and the peak separation.
- Microwave-Enhanced Experiment:
 - Position the cell in the region of maximum electric field within the microwave cavity.
 - Insert the fiber-optic thermometer into the solution, ensuring it is close to the working electrode but not touching it.
 - Apply a low level of microwave power (e.g., 5-10 W). Monitor the temperature closely.
 - Once the temperature stabilizes, record a CV at the same scan rate (100 mV/s).
 - Record the peak currents and peak separation.
 - Repeat at increasing microwave power levels, allowing the temperature to stabilize at each step before recording the CV.
- Data Analysis:
 - Compare the peak currents from the control and microwave-enhanced experiments.
 - Plot the peak current as a function of microwave power or solution temperature.

Data Presentation

The following table presents representative data illustrating the expected enhancement in peak current for the oxidation of **t-Butylferrocene** under microwave irradiation.

Microwave Power (W)	Temperature (°C)	Anodic Peak Current (μA)	Current Enhancement Factor
0 (Control)	25	5.2	1.0
5	40	12.8	2.5
10	55	25.1	4.8
15	70	41.6	8.0

Note: The data in this table is illustrative and based on qualitative descriptions of current enhancement found in the literature. Actual results will vary depending on the specific experimental setup.

Applications in Drug Development

- **High-Throughput Screening:** The accelerated reaction rates can be applied to the rapid electrochemical screening of compound libraries for redox activity.
- **Mechanistic Studies:** By observing the effect of microwave irradiation on electrochemical parameters, insights into reaction mechanisms, particularly those involving coupled chemical steps, can be gained.
- **Electrosynthesis of Metabolites and Analogs:** Microwave-enhanced electrosynthesis can provide a rapid and efficient route for the synthesis of drug metabolites or novel analog structures for structure-activity relationship (SAR) studies. Ferrocene-containing compounds, in particular, have been investigated for their medicinal properties.[2]
- **Biosensor Development:** **t-Butylferrocene** can act as a redox mediator in biosensors.[9] Microwave enhancement could potentially increase the sensitivity and response time of such sensors.

The logical relationship for the application of this technology in drug development can be visualized as follows:

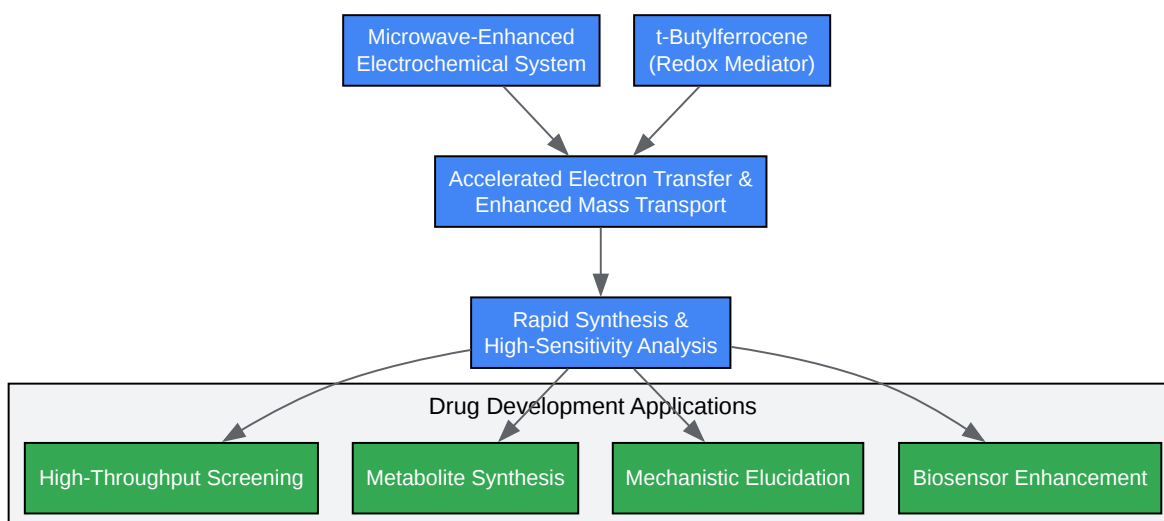

[Click to download full resolution via product page](#)

Diagram 2: Application logic in drug development.

Safety Considerations

- Never operate a microwave reactor with metallic objects inside, other than the specifically designed and shielded electrodes.
- Ensure the microwave reactor is properly shielded to prevent leakage of microwave radiation.
- When working with organic solvents, be aware of their boiling points and the potential for rapid pressure buildup in a closed system. Always use a system with reliable pressure and temperature controls.
- Use appropriate personal protective equipment (PPE), including safety glasses and lab coat.

By following these protocols and considering the safety guidelines, researchers can effectively explore the potential of microwave-enhanced electrochemical processes using **t-Butylferrocene** for a wide range of applications in chemical research and drug development.

Need Custom Synthesis?

BenchChem offers custom synthesis for rare earth carbides and specific isotopic labeling.

Email: info@benchchem.com or [Request Quote Online](#).

References

- [1. researchportal.bath.ac.uk](https://researchportal.bath.ac.uk) [researchportal.bath.ac.uk]
- [2. Contemporary Developments in Ferrocene Chemistry: Physical, Chemical, Biological and Industrial Aspects - PMC](#) [[pmc.ncbi.nlm.nih.gov](https://pubmed.ncbi.nlm.nih.gov/)]
- [3. blogs.rsc.org](https://blogs.rsc.org) [blogs.rsc.org]
- [4. researchgate.net](https://www.researchgate.net) [[researchgate.net](https://www.researchgate.net)]
- [5. rsc.org](https://www.rsc.org) [[rsc.org](https://www.rsc.org)]
- [6. benchchem.com](https://www.benchchem.com) [[benchchem.com](https://www.benchchem.com)]
- [7. mdpi.com](https://www.mdpi.com) [[mdpi.com](https://www.mdpi.com)]
- [8. researchgate.net](https://www.researchgate.net) [[researchgate.net](https://www.researchgate.net)]
- [9. An Electrochemical Evaluation of Novel Ferrocene Derivatives for Glutamate and Liver Biomarker Biosensing - PMC](#) [[pmc.ncbi.nlm.nih.gov](https://pubmed.ncbi.nlm.nih.gov/)]
- To cite this document: BenchChem. [Application Notes and Protocols: Microwave-Enhanced Electrochemical Processes Using t-Butylferrocene]. BenchChem, [2026]. [Online PDF]. Available at: [<https://www.benchchem.com/product/b12061254/docs#application-notes-and-protocols-microwave-enhanced-electrochemical-processes-using-t-butylferrocene>]

Disclaimer & Data Validity:

The information provided in this document is for Research Use Only (RUO) and is strictly not intended for diagnostic or therapeutic procedures. While BenchChem strives to provide accurate protocols, we make no warranties, express or implied, regarding the fitness of this product for every specific experimental setup.

Technical Support: The protocols provided are for reference purposes. Unsure if this reagent suits your experiment?

Need Industrial/Bulk Grade? [Request Custom Synthesis Quote](#)

BenchChem

Our mission is to be the trusted global source of essential and advanced chemicals, empowering scientists and researchers to drive progress in science and industry.

Contact

Address: 3281 E Guasti Rd
Ontario, CA 91761, United States
Phone: (601) 213-4426
Email: info@benchchem.com

[Contact our Ph.D. Support Team for a compatibility check](#)