

Using quinine sulfate hydrate as a chiral resolving agent in HPLC

Author: BenchChem Technical Support Team. **Date:** May 2026

Compound of Interest

Compound Name: Quinine sulfate hydrate

Cat. No.: B1206392

[Get Quote](#)

An Application Guide to Chiral Resolution in HPLC Using Quinine-Based Selectors

Abstract

The enantioselective separation of chiral molecules is a critical challenge in pharmaceutical development, quality control, and stereoselective synthesis. Cinchona alkaloids, particularly quinine, have long been recognized for their exceptional chiral discriminating capabilities. This document provides a detailed technical guide for researchers, scientists, and drug development professionals on the application of quinine as a chiral resolving agent in High-Performance Liquid Chromatography (HPLC). We will explore the two primary methodologies: the use of quinine-derived Chiral Stationary Phases (CSPs) and the application of **quinine sulfate hydrate** as a Chiral Mobile Phase Additive (CMPA). This guide emphasizes the underlying chemical principles, provides field-proven protocols, and offers insights into method development and troubleshooting.

The Foundation: Chiral Recognition with Quinine

Enantiomers possess identical physical and chemical properties in an achiral environment, making their separation a non-trivial task. Chiral chromatography introduces a chiral environment into the HPLC system, allowing for differential interaction with the enantiomers.

This is achieved by forming transient diastereomeric complexes between the analyte enantiomers and a single-enantiomer chiral selector. Quinine, with its rigid structure containing multiple stereogenic centers, serves as an outstanding chiral selector, particularly for acidic chiral compounds.

There are two primary strategies for incorporating quinine into an HPLC system:

- **Direct Separation with Chiral Stationary Phases (CSPs):** In this widely used approach, a quinine derivative is covalently bonded or immobilized onto a solid support (typically silica gel), creating a CSP. The separation occurs as the analyte passes through the column.^{[1][2]}
- **Indirect Separation with Chiral Mobile Phase Additives (CMPA):** Here, an achiral stationary phase is used, and the chiral selector—in this case, **quinine sulfate hydrate**—is dissolved directly into the mobile phase.^{[3][4]} Diastereomeric complexes are formed in the mobile phase, and their differential partitioning with the stationary phase leads to separation.^[4]

Application Protocol I: Quinine-Based Chiral Stationary Phases (Weak Anion-Exchangers)

Quinine-based CSPs, often featuring a carbamate derivative such as O-9-(tert-butylcarbamoyl)quinine, function as highly effective weak anion-exchangers (WAX).^[5] They are the preferred choice for the enantioseparation of ionizable acidic compounds like N-protected amino acids, carboxylic acids, and sulfonic acids.^{[5][6]}

Mechanism of Chiral Recognition on Quinine-Based WAX CSPs

The chiral recognition mechanism is a multi-point interaction model. The primary driving force is a strong electrostatic (ion-exchange) interaction between the protonated quinuclidine nitrogen of the quinine selector (a tertiary amine, acting as the anion-exchange site) and the deprotonated acidic functional group (e.g., carboxylate) of the analyte.^[5] This initial binding brings the analyte into close proximity, allowing for secondary interactions—such as hydrogen bonding, π - π stacking with the quinoline ring, and steric repulsion—to establish the chiral discrimination. The enantiomer that forms the more stable diastereomeric complex is retained longer on the column.

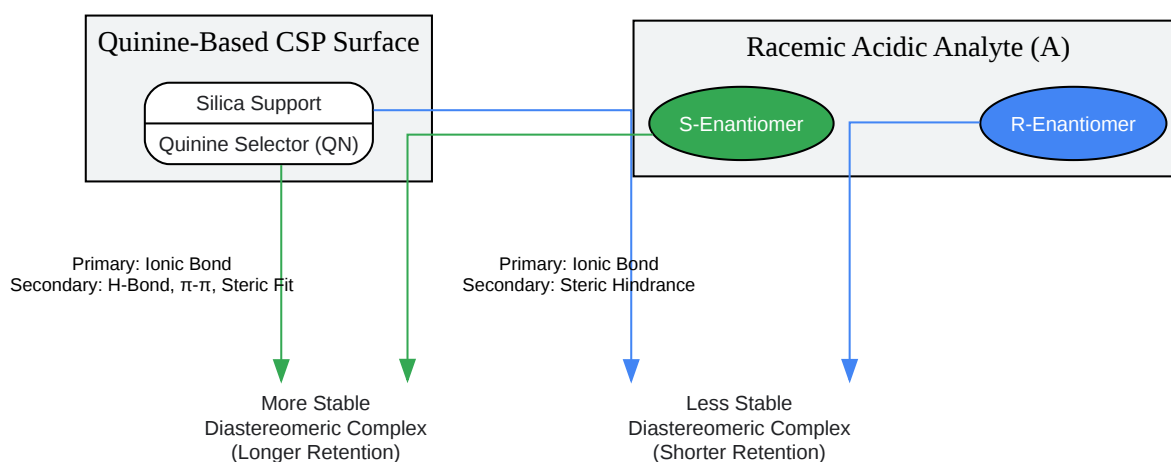

[Click to download full resolution via product page](#)

Figure 1: Chiral recognition mechanism on a quinine-based weak anion-exchange CSP.

Protocol: Method Development for N-Protected Amino Acids on a Quinine-Carbamate CSP

This protocol provides a systematic approach to developing a separation method for acidic analytes like $N\alpha$ -Fmoc protected amino acids.

1. Column Selection:

- Select a quinine-based weak anion-exchange column, such as a Chiralpak QN-AX or a generic equivalent featuring an O-9-(tert-butylcarbamoyl)quinine selector.

2. Mobile Phase Preparation (Polar Ionic Mode):

- Rationale: The mobile phase must contain an acid and a base to control the ionization states of both the selector and the analyte. An excess of acid ensures the selector's amine is protonated and the analyte's acid is in equilibrium, while the base acts as a co-ion.
- Initial Screening Mobile Phase: Prepare a solution of Methanol/Acetonitrile (75/25 v/v) containing 60 mM Formic Acid (FA) and 30 mM Triethylamine (TEA).[6]

- Preparation Steps: a. Measure 750 mL of HPLC-grade Methanol and 250 mL of HPLC-grade Acetonitrile. b. To this mixture, carefully add 2.25 mL of formic acid (~26.6 M) and 4.18 mL of triethylamine (~7.18 M). c. Mix thoroughly and degas the solution by sonication or vacuum filtration.

3. HPLC System Setup:

- Flow Rate: 1.0 mL/min (for a standard 4.6 mm ID column).
- Column Temperature: 25 °C.
- Detection: UV, set to a wavelength appropriate for the analyte (e.g., 262 nm for Fmoc-protected amino acids).[6]
- Injection Volume: 5-10 µL.

4. Sample Preparation:

- Dissolve the racemic analyte in the mobile phase at a concentration of approximately 0.5 - 1.0 mg/mL. Ensure complete dissolution.

5. Method Optimization Workflow:

- If the initial screening does not yield baseline separation (Resolution, $R_s < 1.5$), proceed with the following optimization steps.

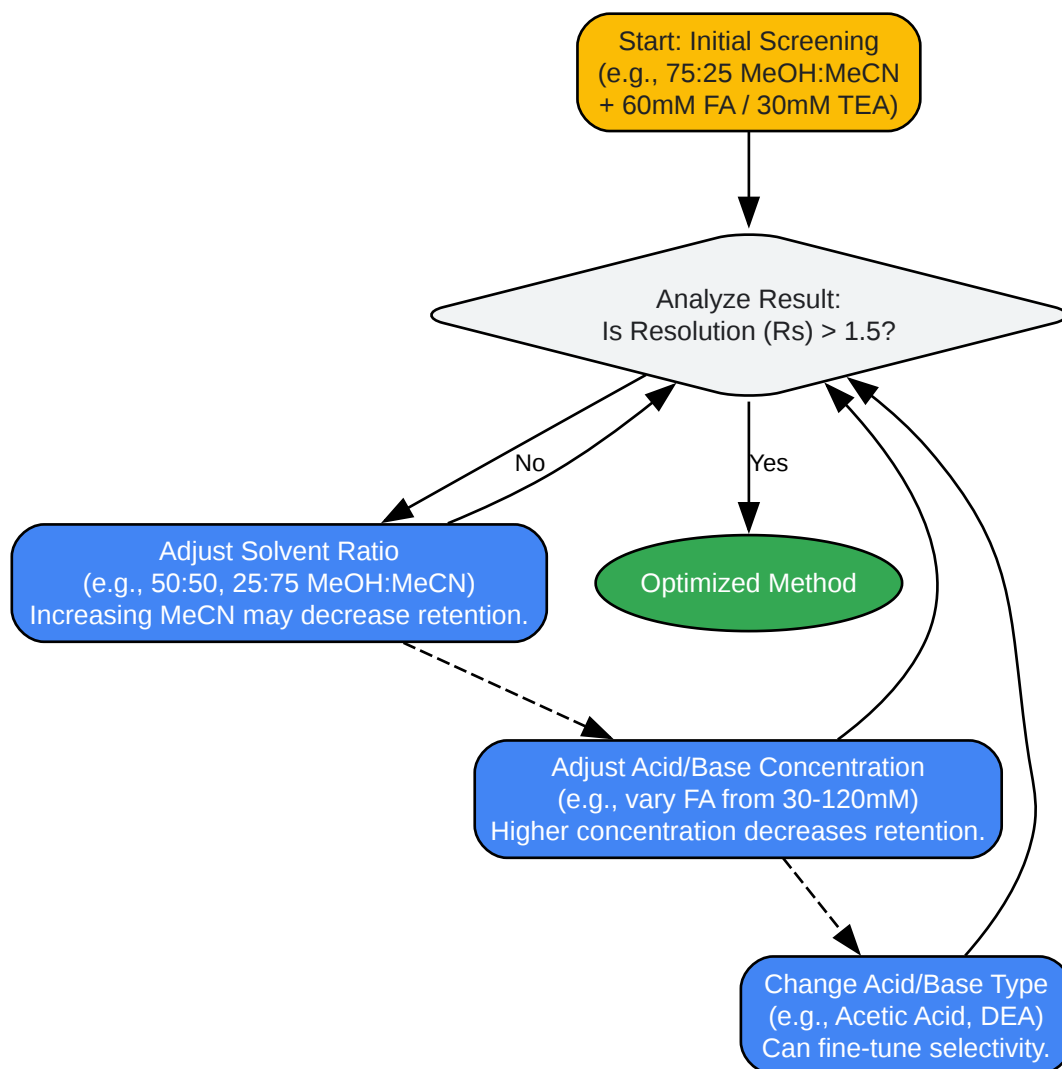

[Click to download full resolution via product page](#)

Figure 2: Workflow for optimizing chiral separations on a quinine-based CSP.

Performance Data

The following table summarizes typical performance data for the separation of various $N\alpha$ -Fmoc amino acids on a quinine-based anion-exchanger CSP (QN-AX™).[6]

Analyte (N α -Fmoc)	Retention Factor (k ₁)	Selectivity Factor (α)	Resolution (R _s)
Asp(OtBu)-OH	2.38	1.82	8.77
Glu(OtBu)-OH	1.97	1.88	9.54
Val-OH	1.88	2.06	12.66
Phe-OH	3.26	1.55	7.74
Trp-OH	4.11	1.64	8.70
Met-OH	2.84	1.67	9.83

Chromatographic conditions: Mobile phase MeOH/MeCN (75/25 v/v) containing 30 mM TEA and 60 mM FA. Data adapted from reference[6].

Application Protocol II: Quinine Sulfate Hydrate as a Chiral Mobile Phase Additive (CMPA)

The CMPA approach is a valuable alternative when a suitable CSP is not available or for specific applications where it offers superior selectivity.[7] By dissolving **quinine sulfate hydrate** in a non-polar mobile phase, it acts as a chiral ion-pairing agent for acidic analytes, which are then separated on a conventional achiral column.

Mechanism of Chiral Recognition via Ion-Pairing

In a non-polar mobile phase, the protonated quinine cation forms a diastereomeric ion-pair with each enantiomer of the deprotonated acidic analyte. These two diastereomeric ion-pairs have different formation constants and/or different affinities for the achiral stationary phase.[4] The difference in the stability and partitioning behavior of these transient complexes allows for their chromatographic separation.

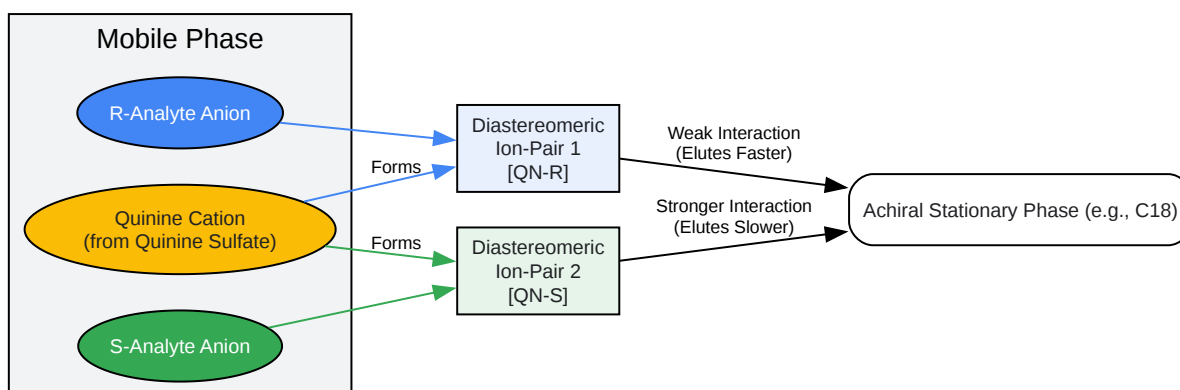

[Click to download full resolution via product page](#)

Figure 3: Chiral recognition via diastereomeric ion-pair formation using a CMPA.

Protocol: Enantioseparation of Acidic Analytes using Quinine Sulfate CMPA

This protocol is based on the successful separation of mandelic acid and 10-camphorsulfonic acid enantiomers.[4][8]

1. Column and System:

- Column: A standard achiral column. A Porous Graphitic Carbon (PGC) column (e.g., Hypercarb) has shown success, but a standard C8 or C18 column can also be screened.[4]
- System: A standard HPLC system is sufficient.

2. Mobile Phase Preparation:

- Rationale: A non-polar organic mobile phase is used to promote ion-pairing. A small amount of acid is added to ensure the analyte is in its anionic form and to improve peak shape.
- Stock Solution of Quinine: Prepare a stock solution of **quinine sulfate hydrate** in a suitable solvent (e.g., methanol) for accurate dilution. Note: The molecular weight of quinine sulfate

dihydrate is 782.9 g/mol ; each mole contains two moles of quinine.

- Final Mobile Phase (Example): Dichloromethane/Cyclohexane (50/50 v/v) containing 0.10 mM Quinine and 0.008% (v/v) Acetic Acid.[4]
- Preparation Steps: a. Prepare a 10 mM stock of quinine. Dissolve 39.15 mg of quinine sulfate dihydrate in a 10 mL volumetric flask with methanol. b. In a 1 L flask, combine 500 mL of HPLC-grade Dichloromethane and 500 mL of HPLC-grade Cyclohexane. c. Add 1.0 mL of the 10 mM quinine stock solution to the 1 L of solvent mixture. d. Add 80 μ L of glacial acetic acid. e. Mix thoroughly and degas. Caution: Work in a well-ventilated fume hood.

3. HPLC Parameters:

- Flow Rate: 1.0 - 1.5 mL/min.
- Column Temperature: Ambient or controlled at 25 °C.
- Detection: UV, set to a wavelength where the analyte absorbs (e.g., 257 nm for mandelic acid).[4]

4. Method Optimization:

- Quinine Concentration: The concentration of the CMPA is a critical parameter. Test concentrations from 0.05 mM to 0.5 mM. Higher concentrations can increase retention and resolution but may also lead to peak broadening.
- Organic Solvents: The choice and ratio of non-polar solvents (e.g., hexane, dichloromethane, ethyl acetate) will significantly impact the separation.
- Acid Modifier: The type and concentration of the acid modifier (e.g., acetic acid, TFA) affect the ionization state and can fine-tune selectivity.

Parameter	Starting Condition	Rationale & Optimization Strategy
Stationary Phase	Porous Graphitic Carbon or C18	PGC offers unique retention mechanisms. Screen standard achiral phases.
Mobile Phase	Dichloromethane/Cyclohexane (50:50)	Adjust polarity to control retention. Hexane/Ethanol is another common system.
CMPA Concentration	0.10 mM Quinine	Vary concentration to balance resolution and peak shape.
Acid Modifier	0.008% Acetic Acid	Controls ionization. Vary concentration or switch to TFA to alter selectivity.

Troubleshooting Guide

Issue	Potential Cause(s)	Recommended Solution(s)
Loss of Resolution	Column Contamination/Aging; Change in mobile phase composition.	Flush column with a strong solvent. For CSPs, check manufacturer's regeneration procedure. Always use a new column for new method development to avoid "memory effects". ^[9] ^[10]
Poor Peak Shape (Tailing)	Secondary interactions (e.g., with silica silanols); Mismatch between sample solvent and mobile phase.	Add a competing base (e.g., TEA) to the mobile phase for basic analytes (less common with quinine methods for acids). Ensure the sample is dissolved in the mobile phase.
Irreproducible Retention Times	Insufficient column equilibration; Mobile phase instability; Pump malfunction.	Equilibrate the column with at least 10-20 column volumes of the mobile phase. Prepare fresh mobile phase daily. Check pump performance and prime all lines. ^[11]
No Separation	Incorrect mobile phase pH; Inappropriate stationary phase (for CMPA); Insufficient interaction.	Ensure mobile phase pH facilitates the necessary ionic interactions. For CMPA, screen different achiral columns. For CSP, the analyte may not be suitable for an anion-exchange mechanism.

Conclusion

Quinine and its derivatives are powerful and versatile chiral selectors for HPLC. Quinine-based CSPs provide a robust and highly efficient platform for the direct separation of acidic enantiomers through a well-understood anion-exchange mechanism. For applications requiring a different selectivity profile, using **quinine sulfate hydrate** as a chiral mobile phase additive

offers a flexible and effective alternative based on chiral ion-pair formation. A systematic approach to method development, focusing on the careful optimization of mobile phase composition, is key to unlocking the full potential of these Cinchona alkaloid-based selectors for tackling complex chiral separation challenges.

References

- Chiralpedia. (2022). Chiral HPLC separation: strategy and approaches. Available at: [\[Link\]](#)
- Nagar, H., & Bhushan, R. (n.d.). Enantioresolution of dl-selenomethionine by thin silica gel plates impregnated with (-) quinine and reversed-phase TLC and HPLC separation of diastereomers... Analytical Methods (RSC Publishing). Available at: [\[Link\]](#)
- Al-Saeed, F. A., et al. (2021). Development and Validation of a Chiral Liquid Chromatographic Assay for Enantiomeric Separation and Quantification of Verapamil in Rat Plasma. National Institutes of Health. Available at: [\[Link\]](#)
- MicroSolv Technology Corporation. (n.d.). Quinine Sulfate and Impurity Analysis with HPLC - AppNote. Available at: [\[Link\]](#)
- Research Journal of Pharmacy and Technology. (n.d.). A Validated Chiral HPLC Method for the Enantiomeric separation of Mefloquine. Available at: [\[Link\]](#)
- PubMed. (n.d.). Enantiomeric separation of N-protected amino acids by non-aqueous capillary electrophoresis with dimeric forms of quinine and quinidine derivatives serving as chiral selectors. Available at: [\[Link\]](#)
- Fegas, A., et al. (n.d.). Chromatographic Separation of Enantiomers Acids Using Quinine as Chiral Counter-Ion in Mobile Phase. Asian Journal of Chemistry. Available at: [\[Link\]](#)
- RSC Publishing. (n.d.). Quinine as a highly responsive chiral sensor for the 1H and 19F NMR enantiodiscrimination of N-trifluoroacetyl amino acids with free carboxyl functions. Available at: [\[Link\]](#)
- ResearchGate. (n.d.). Chromatographic separation of enantiomers acids using quinine as chiral counter-ion in mobile phase. Available at: [\[Link\]](#)

- Chromatography Today. (2020). Trouble with chiral separations. Available at: [\[Link\]](#)
- ResearchGate. (n.d.). Quinine-Based Zwitterionic Chiral Stationary Phase as a Complementary Tool for Peptide Analysis. Available at: [\[Link\]](#)
- Galochrom s.r.o. (2024). Chiral ION-QN & Chiral ION-QD - HPLC. Available at: [\[Link\]](#)
- LCGC International. (n.d.). A Strategy for Developing HPLC Methods for Chiral Drugs. Available at: [\[Link\]](#)
- IJNRD. (n.d.). Simultaneously Estimation of Quinine Sulphate: RP HPLC Techniques. Available at: [\[Link\]](#)
- Beata, T., et al. (n.d.). A Comparative Study of Enantioseparations of N α -Fmoc Proteinogenic Amino Acids on Quinine-Based Zwitterionic and Anion Exchanger-Type Chiral Stationary Phases... National Institutes of Health. Available at: [\[Link\]](#)
- Agilent. (2023). It Isn't Always The Column: Troubleshooting Your HPLC Separation. Available at: [\[Link\]](#)
- ORBi. (n.d.). Enantiomeric separation of amino acid derivatives by non-aqueous capillary electrophoresis using quinine and related. Available at: [\[Link\]](#)
- Chiral Technologies. (n.d.). Troubleshoot Chiral Column Performance: Efficiency & Resolution. Available at: [\[Link\]](#)
- PubMed. (2009). Investigations of mobile phase contributions to enantioselective anion- and zwitterion-exchange modes on quinine-based zwitterionic chiral stationary phases. Available at: [\[Link\]](#)

Need Custom Synthesis?

BenchChem offers custom synthesis for rare earth carbides and specific isotopic labeling.

Email: info@benchchem.com or [Request Quote Online](#).

Sources

- [1. researchgate.net \[researchgate.net\]](#)
- [2. chromatographyonline.com \[chromatographyonline.com\]](#)
- [3. Chiral HPLC separation: strategy and approaches – Chiralpedia \[chiralpedia.com\]](#)
- [4. asianpubs.org \[asianpubs.org\]](#)
- [5. hplc.eu \[hplc.eu\]](#)
- [6. A Comparative Study of Enantioseparations of N \$\alpha\$ -Fmoc Proteinogenic Amino Acids on Quinine-Based Zwitterionic and Anion Exchanger-Type Chiral Stationary Phases under Hydro-Organic Liquid and Subcritical Fluid Chromatographic Conditions - PMC \[pmc.ncbi.nlm.nih.gov\]](#)
- [7. rjptonline.org \[rjptonline.org\]](#)
- [8. researchgate.net \[researchgate.net\]](#)
- [9. chromatographytoday.com \[chromatographytoday.com\]](#)
- [10. chiraltech.com \[chiraltech.com\]](#)
- [11. agilent.com \[agilent.com\]](#)
- To cite this document: BenchChem. [Using quinine sulfate hydrate as a chiral resolving agent in HPLC]. BenchChem, [2026]. [Online PDF]. Available at: [\[https://www.benchchem.com/product/b1206392/docs#using-quinine-sulfate-hydrate-as-a-chiral-resolving-agent-in-hplc\]](https://www.benchchem.com/product/b1206392/docs#using-quinine-sulfate-hydrate-as-a-chiral-resolving-agent-in-hplc)

Disclaimer & Data Validity:

The information provided in this document is for Research Use Only (RUO) and is strictly not intended for diagnostic or therapeutic procedures. While BenchChem strives to provide accurate protocols, we make no warranties, express or implied, regarding the fitness of this product for every specific experimental setup.

Technical Support: The protocols provided are for reference purposes. Unsure if this reagent suits your experiment?

Need Industrial/Bulk Grade? [Request Custom Synthesis Quote](#)

BenchChem

Our mission is to be the trusted global source of essential and advanced chemicals, empowering scientists and researchers to drive progress in science and industry.

Contact

Address: 3281 E Guasti Rd

Ontario, CA 91761, United States

Phone: (601) 213-4426

Email: info@benchchem.com

[Contact our Ph.D. Support Team for a compatibility check](#)