

Application Notes & Protocols: Catalytic Enantioselective Reactions with Chiral Zinc Complexes

Author: BenchChem Technical Support Team. **Date:** April 2026

Compound of Interest

Compound Name: (R)-(+)-3-methoxy-2-methyl-3-oxopropylzinc bromide

Cat. No.: B12059581

[Get Quote](#)

Introduction: The Strategic Advantage of Chiral Zinc Catalysis

In the landscape of asymmetric synthesis, the pursuit of catalysts that are not only efficient and selective but also sustainable and economical is paramount. Chiral zinc complexes have emerged as a formidable class of catalysts that elegantly meet these criteria. Zinc's natural abundance, low toxicity, and well-defined Lewis acidity make it an ideal metallic core for catalytic applications.^{[1][2]} When coordinated with readily accessible chiral ligands, zinc(II) ions form structurally defined complexes capable of creating a potent chiral environment. This environment meticulously orchestrates the approach of substrates to the active site, enabling a wide array of chemical transformations to proceed with remarkable levels of enantioselectivity.

These catalysts have proven their versatility in numerous key C-C and C-N bond-forming reactions, including nucleophilic additions to carbonyls and imines, aldol-type reactions, and cycloadditions. This guide provides an in-depth exploration of the principles, applications, and

detailed protocols for several cornerstone reactions mediated by chiral zinc complexes, designed for researchers and professionals in synthetic chemistry and drug development.

Enantioselective Addition of Organozinc Reagents to Aldehydes and Imines

The addition of organometallic reagents to prochiral carbonyls and imines is one of the most fundamental and powerful methods for constructing stereogenic centers. Chiral zinc complexes are exceptionally proficient at catalyzing the addition of dialkylzinc reagents, affording valuable chiral alcohols and amines with high enantiopurity.

Core Principle & Mechanistic Insight

The most widely accepted mechanism for the alkylation of aldehydes, catalyzed by chiral β -amino alcohols, involves the formation of a dinuclear zinc complex.^[3] The reaction is initiated by the interaction between the chiral ligand (L^*H) and the dialkylzinc reagent (R_2Zn) to form a monomeric zinc alkoxide intermediate. This species then dimerizes or reacts with another equivalent of R_2Zn to form a bridged, dinuclear zinc catalytic core.

Within this dinuclear complex, one zinc atom functions as a Lewis acid, activating the aldehyde by coordinating to its carbonyl oxygen. The other zinc atom, part of the chiral alkoxide, serves to deliver the alkyl group (R) from a zinc-carbon bond to one specific face of the activated aldehyde. The stereochemical outcome is dictated by the rigid, chair-like six-membered transition state, often rationalized by the Zimmerman-Traxler model, which minimizes steric interactions.^[3]

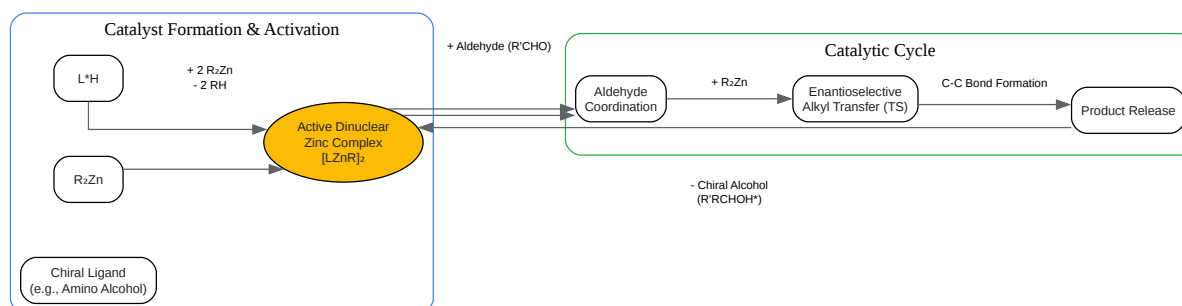

[Click to download full resolution via product page](#)

Figure 1: Generalized catalytic cycle for the enantioselective addition of diethylzinc to an aldehyde.

Application Note: Synthesis of Chiral Secondary Alcohols

The synthesis of enantiomerically pure secondary alcohols is a critical transformation in the production of active pharmaceutical ingredients (APIs) and natural products.[3] Chiral zinc catalysis provides a direct and reliable route to these valuable building blocks. A wide variety of chiral ligands, including those derived from carbohydrates, terpenes, and amino acids, have been developed, offering excellent enantioselectivity across a broad scope of aldehyde substrates.[4][5][6]

Table 1: Representative Performance in Diethylzinc Addition to Aldehydes

Entry	Aldehyde	Chiral Ligand Type	Yield (%)	ee (%)	Reference
1	Benzaldehyde	Pinane-derived Amino Alcohol	85	96	[3]
2	Benzaldehyde	Fructose-derived β -amino alcohol	100	92	[4]
3	4-Chlorobenzaldehyde	Fructose-derived β -amino alcohol	100	96	[4]
4	Cyclohexane carboxaldehyde	Pinane-derived Amino Alcohol	93	86	[3]

| 5 | Isovaleraldehyde | Phenyl-piperidinopropane-1-thiol | >95 | >99 |[5] |

Protocol 1: General Procedure for Enantioselective Diethylzinc Addition to Aldehydes

This protocol describes a general method for the catalytic enantioselective addition of diethylzinc to an aldehyde using a chiral amino alcohol ligand.[3][4]

A. Materials & Reagents:

- Chiral β -amino alcohol ligand (e.g., (+)-isopinocampheol-derived) (5 mol%)
- Aldehyde (1.0 equiv)
- Diethylzinc (1.0 M solution in hexanes, 2.4 equiv)
- Anhydrous Toluene or Hexane

- Saturated aqueous NH_4Cl solution
- Anhydrous MgSO_4 or Na_2SO_4
- Standard silica gel for chromatography

B. Equipment:

- Flame-dried, two-neck round-bottom flask with a magnetic stir bar
- Schlenk line or inert gas (Argon/Nitrogen) manifold
- Septa and needles/syringes
- Ice-water bath (0 °C)

C. Step-by-Step Methodology:

- Catalyst Preparation: To the flame-dried flask under a positive pressure of inert gas, add the chiral amino alcohol ligand (0.05 mmol, 5 mol%).
- Add anhydrous toluene (2 mL) via syringe and stir to dissolve the ligand.
- Cool the solution to 0 °C in an ice bath.
- Reaction Initiation: Slowly add the aldehyde (1.0 mmol, 1.0 equiv) to the cooled ligand solution.
- To this stirring solution, add diethylzinc (2.4 mL of a 1.0 M solution in hexanes, 2.4 mmol) dropwise via syringe over 10-15 minutes. Caution: Diethylzinc is pyrophoric and reacts violently with water and air. Handle with extreme care under an inert atmosphere.
- Reaction Monitoring: Stir the reaction mixture at 0 °C. Monitor the progress by thin-layer chromatography (TLC) until the starting aldehyde is consumed (typically 2-6 hours).
- Quenching: Once the reaction is complete, carefully quench the reaction at 0 °C by the slow, dropwise addition of saturated aqueous NH_4Cl solution (5 mL). Vigorous gas evolution will occur.

- **Workup:** Allow the mixture to warm to room temperature. Transfer the mixture to a separatory funnel and extract with ethyl acetate or diethyl ether (3 x 15 mL).
- Combine the organic layers, wash with brine (1 x 15 mL), and dry over anhydrous MgSO_4 .
- **Purification & Analysis:** Filter the drying agent and concentrate the filtrate under reduced pressure. Purify the crude product by flash column chromatography on silica gel.
- Determine the enantiomeric excess (ee) of the purified alcohol by chiral HPLC or GC analysis.

Enantioselective Aldol, Henry (Nitroaldol), and Reformatsky Reactions

These classic C-C bond-forming reactions are cornerstones of organic synthesis. Chiral zinc complexes function as potent Lewis acids, activating the electrophilic carbonyl component and controlling the facial selectivity of the incoming nucleophile (an enolate, nitronate, or zinc enolate).

Core Principle & Mechanistic Insight

In these transformations, the chiral Zn(II) center coordinates to the aldehyde or ketone, increasing its electrophilicity. For the direct aldol reaction, the zinc complex also facilitates the deprotonation of the ketone to form a chiral zinc enolate.^[7] Similarly, in the Henry reaction, the complex coordinates both the aldehyde and the nitroalkane, promoting the formation of a zinc nitronate intermediate. The subsequent C-C bond formation occurs within the well-defined chiral pocket of the catalyst, leading to high stereocontrol. Dinuclear zinc catalysts have been shown to be particularly effective, where one zinc center activates the electrophile and the other controls the nucleophile geometry.^[7]

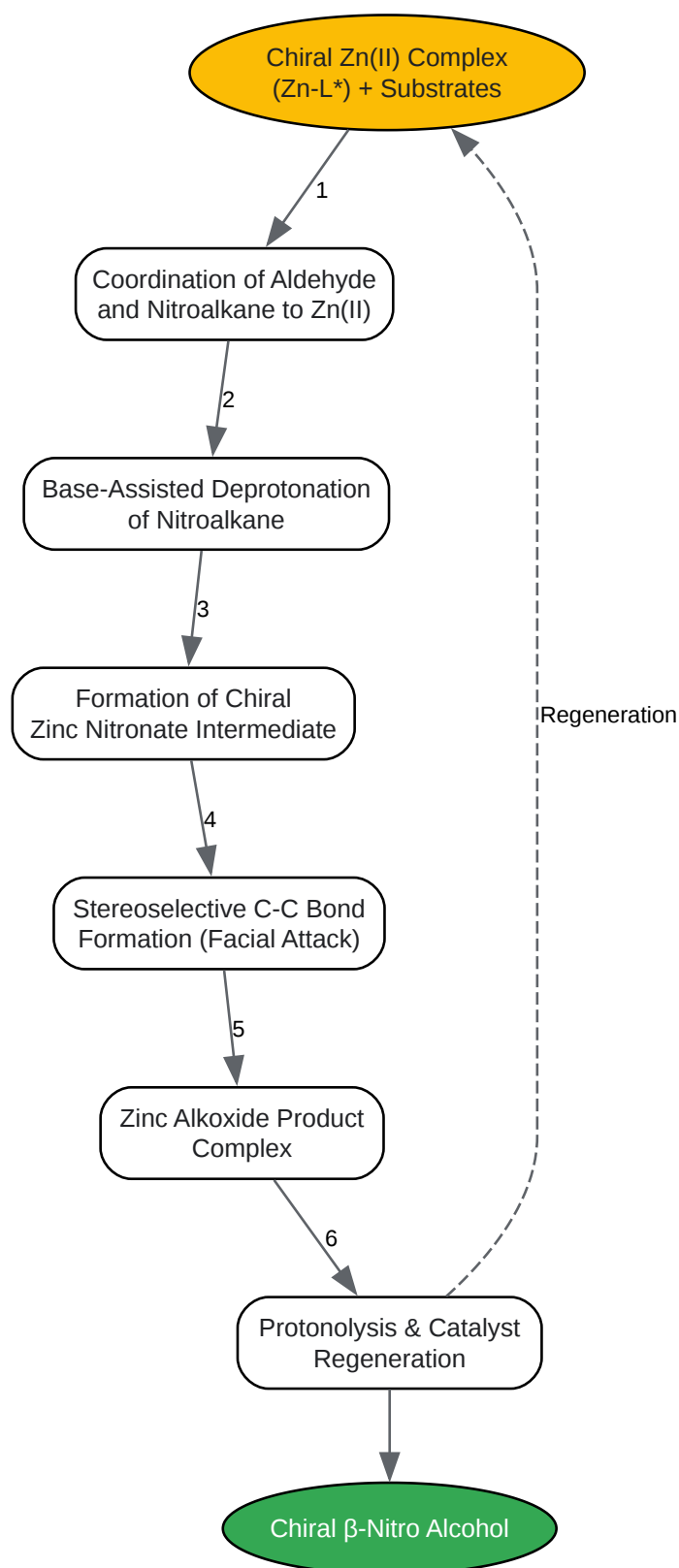

[Click to download full resolution via product page](#)

Figure 2: Key steps in a chiral zinc-catalyzed asymmetric Henry (nitroaldol) reaction.

Application Note: The Asymmetric Reformatsky Reaction

The Reformatsky reaction is a powerful method for synthesizing β -hydroxy esters.[8][9] The development of catalytic enantioselective versions using chiral zinc complexes has significantly enhanced its utility. Protocols mediated by dimethylzinc (Me_2Zn) in the presence of a catalytic amount of a chiral ligand, such as a prolinol derivative, have proven highly effective for a range of aldehydes and ketones.[8][10] This approach provides excellent yields and enantioselectivities, offering a practical route to valuable chiral synthons.[10]

Table 2: Performance of a Prolinol/ Me_2Zn System in the Enantioselective Reformatsky Reaction

Entry	Electrophile	Yield (%)	ee (%)	Reference
1	Benzaldehyde	95	96	[10]
2	4-Methoxybenzaldehyde	98	95	[10]
3	2-Naphthaldehyde	92	93	[10]
4	Cinnamaldehyde	90	91	[10]

| 5 | Acetophenone | 85 | 86 |[10] |

Protocol 2: Catalytic Enantioselective Reformatsky Reaction with a Prolinol Ligand

This protocol is adapted from a highly efficient Me_2Zn -mediated procedure.[10]

A. Materials & Reagents:

- (S)-(-)- α,α -Diphenyl-2-pyrrolidinemethanol (Prolinol ligand L5) (20 mol%)
- Triphenylphosphine oxide ($\text{Ph}_3\text{P}=\text{O}$) (20 mol%)

- Aldehyde or Ketone (1.0 equiv)
- Ethyl iodoacetate (2.0 equiv)
- Dimethylzinc (Me_2Zn , 2.0 M in toluene, 4.0 equiv)
- Anhydrous solvent (e.g., Toluene or CH_2Cl_2)
- Saturated aqueous NaHCO_3 solution
- Anhydrous Na_2SO_4

B. Equipment:

- Flame-dried Schlenk tube with a magnetic stir bar
- Inert gas (Argon/Nitrogen) manifold
- Syringes and septa
- Cryocool or ice-water bath (0 °C)

C. Step-by-Step Methodology:

- Catalyst Premixing: In a flame-dried Schlenk tube under an inert atmosphere, combine the prolinol ligand (0.1 mmol, 20 mol%) and $\text{Ph}_3\text{P}=\text{O}$ (0.1 mmol, 20 mol%).
- Add anhydrous solvent (3 mL) and stir to dissolve.
- Cool the solution to 0 °C.
- Reagent Addition: Add the aldehyde or ketone (0.5 mmol, 1.0 equiv) to the cooled solution.
- Add ethyl iodoacetate (1.0 mmol, 2.0 equiv).
- Slowly, add Me_2Zn (2.0 mmol, 4.0 equiv) dropwise via syringe. Caution: Me_2Zn is highly pyrophoric.
- Reaction: Seal the Schlenk tube and stir the mixture at 0 °C for 12 hours.

- Quenching: After 12 hours, carefully quench the reaction at 0 °C by the slow addition of saturated aqueous NaHCO₃ solution.
- Workup: Allow the mixture to warm to room temperature. Extract with ethyl acetate (3 x 15 mL). Combine the organic layers, wash with brine, and dry over anhydrous Na₂SO₄.
- Purification & Analysis: Filter and concentrate the organic phase. Purify the residue by flash column chromatography to obtain the β-hydroxy ester.
- Determine the enantiomeric excess by chiral HPLC analysis.

Enantioselective Cycloaddition Reactions

Cycloaddition reactions are among the most elegant and atom-economical methods for constructing complex cyclic architectures. Chiral zinc complexes serve as effective Lewis acid catalysts, activating one of the reacting partners and controlling the stereochemistry of the newly formed ring system.

Core Principle & Mechanistic Insight

In reactions like the [3+2] cycloaddition of azomethine ylides, the chiral zinc(II) complex, typically formed from Zn(OTf)₂ and a chiral ligand, coordinates to the dipolarophile (e.g., an enone or maleimide).^[11] This coordination lowers the LUMO energy of the dipolarophile, accelerating the reaction, and blocks one of its prochiral faces. The azomethine ylide, generated in situ, then attacks the activated dipolarophile from the less sterically hindered face, leading to the formation of the pyrrolidine ring with high stereocontrol.^{[11][12]}

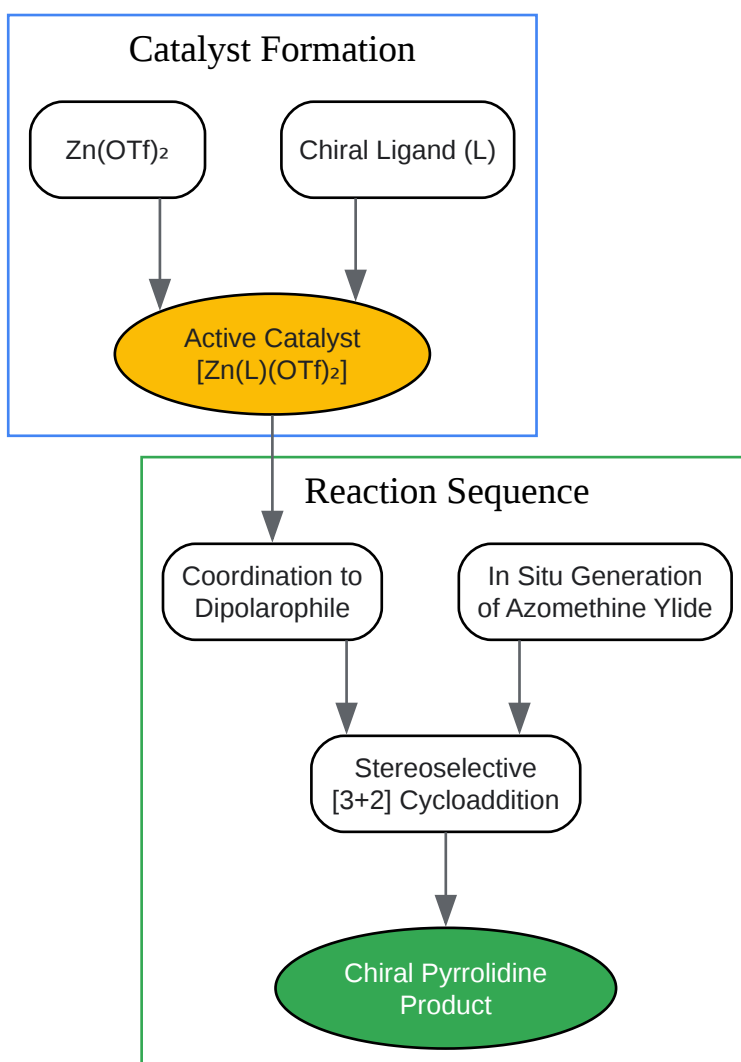

[Click to download full resolution via product page](#)

Figure 3: Experimental workflow for a Zn(II)-catalyzed asymmetric [3+2] cycloaddition.

Application Note: Asymmetric Synthesis of Pyrrolidines

The pyrrolidine scaffold is a privileged structure found in a vast number of natural products and pharmaceuticals.^[11] The zinc-catalyzed [3+2] cycloaddition between azomethine ylides and various electron-deficient olefins provides a highly convergent and atom-economical route to construct these valuable heterocycles with multiple stereocenters.^{[11][12]}

Table 3: Zn(II)/UCD-Imphanol Catalyzed [3+2] Cycloaddition of Acyclic Enones

Entry	Acyclic Enone (Dipolarophile)	Yield (%)	endo/exo	ee (%) [endo]	Reference
1	Chalcone	94	>99:1	95	[11]
2	4'-Methylchalcone	92	>99:1	94	[11]
3	4'-Bromochalcone	85	>99:1	96	[11]

| 4 | (E)-1,3-diphenylprop-2-en-1-one | 94 | >99:1 | 95 |[11] |

Protocol 3: General Procedure for Zn(II)-Catalyzed Asymmetric [3+2] Cycloaddition

This protocol is based on the highly endo-selective cycloaddition with acyclic enones.[11]

A. Materials & Reagents:

- Zinc trifluoromethanesulfonate (Zn(OTf)₂) (10 mol%)
- Chiral Ligand (e.g., UCD-Imphanol) (11.5 mol%)
- Acyclic enone (dipolarophile) (1.0 equiv)
- α -Iminoester (azomethine ylide precursor) (2.0 equiv)
- DABCO (1,4-diazabicyclo[2.2.2]octane) (10 mol%)
- Anhydrous Dichloromethane (CH₂Cl₂)

B. Equipment:

- Flame-dried Schlenk tube

- Inert gas (Argon/Nitrogen) manifold
- Syringes and septa
- Cryocool or ice-water bath (0 °C)

C. Step-by-Step Methodology:

- Catalyst Formation: Under a nitrogen atmosphere, add the chiral ligand (11.5 mol%) and Zn(OTf)₂ (10 mol%) to a flame-dried Schlenk tube.
- Add dry CH₂Cl₂ (0.5 mL) and stir at room temperature for 60 minutes to allow for complex formation.
- Reaction Setup: Cool the catalyst solution to 0 °C.
- Sequentially add a solution of the acyclic enone (0.15 mmol, 1.0 equiv) in CH₂Cl₂ (0.4 mL), a solution of the α-iminoester (0.3 mmol, 2.0 equiv) in CH₂Cl₂ (0.4 mL), and a solution of DABCO (10 mol%) in CH₂Cl₂ (0.2 mL).
- Reaction: Stir the reaction mixture at 0 °C for the required time (e.g., 48 hours), monitoring by TLC.
- Workup: Upon completion, concentrate the reaction mixture under reduced pressure.
- Purification & Analysis: Purify the crude residue by flash column chromatography on silica gel.
- Determine the yield, diastereomeric ratio (endo/exo), and enantiomeric excess (ee) of the major diastereomer by ¹H NMR and chiral HPLC analysis.

References

- Design and Synthesis of Chiral Zn²⁺ Complexes Mimicking Natural Aldolases for Catalytic C–C Bond Forming Reactions in Aqueous Solution. MDPI. [\[Link\]](#)
- Zn-catalyzed Enantio- and Diastereoselective Formal [4+2] Cycloaddition Involving Two Electron-Deficient Partners: Asymmetric Synthesis of Piperidines from 1-Azadienes and

Nitroalkenes. PMC. [\[Link\]](#)

- New zinc(II)-based catalyst for asymmetric azomethine ylide cycloaddition reactions. PubMed. [\[Link\]](#)
- New Zinc(II)-Based Catalyst for Asymmetric Azomethine Ylide Cycloaddition Reactions. Amanote Research. [\[Link\]](#)
- Carbohydrate-Based Chiral Ligands for the Enantioselective Addition of Diethylzinc to Aldehydes. MDPI. [\[Link\]](#)
- Zn(II)-Catalyzed Asymmetric Reactions of Aminocyclopropanes: (3 + 2) Cycloaddition with Thioketones and Ring Opening with Thioureas. ACS Publications. [\[Link\]](#)
- Catalytic Asymmetric Nitroaldol (Henry) Reaction with a Zinc-Fam Catalyst. ACS Publications. [\[Link\]](#)
- Chiral proline-derived Zn(ii) complexes as catalysts for ring-opening polymerization and ring-opening copolymerization reactions. RSC Publishing. [\[Link\]](#)
- Zn(II)-catalyzed asymmetric [3 + 2] cycloaddition of acyclic enones with azomethine ylides. RSC Publishing. [\[Link\]](#)
- Asymmetric aza-Henry reaction of BOC-protected imines with zinc-FAM catalyst. Taylor & Francis Online. [\[Link\]](#)
- Dinuclear Zinc-AzePhenol Catalyzed Asymmetric Aza-Henry Reaction of N-Boc Imines and Nitroalkanes under Ambient Conditions. ACS Publications. [\[Link\]](#)
- Enantioselective addition of diethylzinc to α -branched aldehydes. RSC Publishing. [\[Link\]](#)
- Chiral Zinc Catalysts for Asymmetric Synthesis. ResearchGate. [\[Link\]](#)
- Chiral proline-derived Zn(ii) complexes as catalysts for ring-opening polymerization and ... RSC Publishing. [\[Link\]](#)
- Recent Advances in Zinc Complexes for Stereoselective Ring-Opening Polymerization and Copolymerization. MDPI. [\[Link\]](#)

- Highly Catalytic Enantioselective Reformatsky Reaction with Aldehydes and Ketones Using an Available Prolinol Ligand. ACS Publications. [\[Link\]](#)
- Asymmetric construction of tetrahedral chiral zinc with high configurational stability and catalytic activity. SciSpace. [\[Link\]](#)
- Asymmetric construction of tetrahedral chiral zinc with high configurational stability and catalytic activity. PubMed. [\[Link\]](#)
- Catalytic asymmetric nitroaldol (Henry) reaction with a zinc-Fam catalyst. PubMed. [\[Link\]](#)
- Highly Catalytic Enantioselective Reformatsky Reaction with Aldehydes and Ketones Using an Available Prolinol Ligand. PMC. [\[Link\]](#)
- Chiral Proline-derived Zn(II) Complexes as Catalysts for Ring-Opening Polymerization and Ring-Opening Copolymerization Reactions. ResearchGate. [\[Link\]](#)
- Recent developments in the asymmetric Reformatsky-type reaction. Beilstein Journals. [\[Link\]](#)
- Artificial Chiral Trinuclear Zn Catalysts: Design, Self-Assembly and Unprecedented Efficiency in Asymmetric Hydroboration of Ketones. ACS Central Science. [\[Link\]](#)
- Enantioselective addition of diethylzinc to aldehydes with (R)-(+)-2 a... ResearchGate. [\[Link\]](#)
- Reformatsky Reaction. reformatsky-reaction.pdf. [\[Link\]](#)
- Theoretical study of the BINOL–zinc complex-catalyzed asymmetric inverse-electron-demand imino Diels–Alder reaction: mechanism and stereochemistry. RSC Publishing. [\[Link\]](#)
- Catalytic Enantioselective Addition of Alkylzirconium Reagents to Aliphatic Aldehydes. PMC. [\[Link\]](#)
- Dinuclear Zn-Catalytic System as Brønsted Base and Lewis Acid for Enantioselectivity in Same Chiral Environment. PMC. [\[Link\]](#)
- Preparation of chiral β -aminoalkylzinc halides of type 4 from optically... ResearchGate. [\[Link\]](#)

- ChemInform Abstract: Zinc Complexes of Chiral Phenols as Catalysts for Enantioselective Addition of Organozinc Reagents to Aldehydes. R Discovery. [\[Link\]](#)
- New chiral amino alcohol ligands for catalytic enantioselective addition of diethylzinc to aldehydes. RSC Publishing. [\[Link\]](#)
- The Asymmetric Dialkylzinc Addition to Imines Catalyzed by [2.2]Paracyclophane-Based N,O-Ligands. Organic Chemistry Portal. [\[Link\]](#)
- C₂-symmetric chiral zinc alkoxides as catalysts for the enantioselective addition of diethylzinc to aryl aldehydes. Scilit. [\[Link\]](#)
- CHAPTER 3: Alkylation of Imines. RSC Publishing. [\[Link\]](#)
- Catalytic Enantioselective Methods for Synthesis of 1,2-Amino Tertiary Alcohols and Their Analogues. PMC. [\[Link\]](#)
- Zinc-Catalyzed Enantioselective Hydrosilylation of Imines. ResearchGate. [\[Link\]](#)
- Bis[(l)prolinate-N,O]Zn: A water-soluble and recycle catalyst for various organic transformations. PMC. [\[Link\]](#)
- Carbohydrate-Based Chiral Ligands for the Enantioselective Addition of Diethylzinc to Aldehydes. MDPI. [\[Link\]](#)
- Development of New Chiral Amino Alcohol Ligand for the Asymmetric Transfer Hydrogenation of Ketones and Its Immobilization Onto. CNR-IRIS. [\[Link\]](#)
- Catalytic Asymmetric Synthesis of Zinc Metallacycles. Organic Chemistry Portal. [\[Link\]](#)
- Linear β -amino alcohol catalyst anchored on functionalized magnetite nanoparticles for enantioselective addition of dialkylzinc to aromatic aldehydes. PMC. [\[Link\]](#)
- Linear β -amino alcohol catalyst anchored on functionalized magnetite nanoparticles for enantioselective addition of dialkylzinc to aromatic aldehydes. RSC Publishing. [\[Link\]](#)
- Carbohydrate-Based Chiral Ligands for the Enantioselective Addition of Diethylzinc to Aldehydes. PMC. [\[Link\]](#)

Need Custom Synthesis?

BenchChem offers custom synthesis for rare earth carbides and specific isotopic labeling.

Email: info@benchchem.com or [Request Quote Online](#).

Sources

- 1. Dinuclear Zn-Catalytic System as Brønsted Base and Lewis Acid for Enantioselectivity in Same Chiral Environment - PMC [[pmc.ncbi.nlm.nih.gov](https://pubmed.ncbi.nlm.nih.gov)]
- 2. [researchgate.net](https://www.researchgate.net) [[researchgate.net](https://www.researchgate.net)]
- 3. pdf.benchchem.com [pdf.benchchem.com]
- 4. Carbohydrate-Based Chiral Ligands for the Enantioselective Addition of Diethylzinc to Aldehydes | MDPI [[mdpi.com](https://www.mdpi.com)]
- 5. Enantioselective addition of diethylzinc to α -branched aldehydes - Journal of the Chemical Society, Chemical Communications (RSC Publishing) [pubs.rsc.org]
- 6. New chiral amino alcohol ligands for catalytic enantioselective addition of diethylzinc to aldehydes - Organic & Biomolecular Chemistry (RSC Publishing) [pubs.rsc.org]
- 7. [mdpi.com](https://www.mdpi.com) [[mdpi.com](https://www.mdpi.com)]
- 8. Highly Catalytic Enantioselective Reformatsky Reaction with Aldehydes and Ketones Using an Available Prolinol Ligand - PMC [[pmc.ncbi.nlm.nih.gov](https://pubmed.ncbi.nlm.nih.gov)]
- 9. Reformatsky Reaction (Chapter 95) - Name Reactions in Organic Synthesis [[cambridge.org](https://www.cambridge.org)]
- 10. pubs.acs.org [pubs.acs.org]
- 11. Zn(II)-catalyzed asymmetric [3 + 2] cycloaddition of acyclic enones with azomethine ylides - Organic & Biomolecular Chemistry (RSC Publishing) DOI:10.1039/D4OB00854E [pubs.rsc.org]
- 12. New zinc(II)-based catalyst for asymmetric azomethine ylide cycloaddition reactions - PubMed [pubmed.ncbi.nlm.nih.gov]
- To cite this document: BenchChem. [Application Notes & Protocols: Catalytic Enantioselective Reactions with Chiral Zinc Complexes]. BenchChem, [2026]. [Online PDF]. Available at: [<https://www.benchchem.com/product/b12059581/docs#application-notes-protocols-catalytic-enantioselective-reactions-with-chiral-zinc-complexes>]

Disclaimer & Data Validity:

The information provided in this document is for Research Use Only (RUO) and is strictly not intended for diagnostic or therapeutic procedures. While BenchChem strives to provide accurate protocols, we make no warranties, express or implied, regarding the fitness of this product for every specific experimental setup.

Technical Support: The protocols provided are for reference purposes. Unsure if this reagent suits your experiment?

Need Industrial/Bulk Grade? [Request Custom Synthesis Quote](#)

BenchChem

Our mission is to be the trusted global source of essential and advanced chemicals, empowering scientists and researchers to drive progress in science and industry.

Contact

Address: 3281 E Guasti Rd
Ontario, CA 91761, United States
Phone: (601) 213-4426
Email: info@benchchem.com

[Contact our Ph.D. Support Team for a compatibility check](#)