

# Technical Support Center: Fluorescent Red Mega 500 Assay Optimization

**Author:** BenchChem Technical Support Team. **Date:** May 2026

## Compound of Interest

Compound Name: *Fluorescent Red Mega 500*

Cat. No.: *B12058957*

[Get Quote](#)

## Technical Overview: The Physics of Compatibility

Welcome to the technical support center. To troubleshoot "**Fluorescent Red Mega 500**" assays effectively, we must first understand the photophysics driving this fluorophore.

**Fluorescent Red Mega 500** is not a standard passive label; it is an environment-sensitive Large Stokes Shift (LSS) probe. Its fluorescence mechanism relies on Twisted Intramolecular Charge Transfer (TICT).[1]

- In Polar Solvents (Buffer): The dye adopts a twisted conformation (TICT state) upon excitation, which is non-radiative.[1] The quantum yield is near zero (Dark).
- In Apolar Environments (Protein Pockets/Hydrophobic Cores): The twisted state is thermodynamically unfavorable.[1] The molecule remains planar, resulting in high fluorescence (Bright).

The Detergent Paradox: Detergents are necessary to prevent compound aggregation (false positives) in High-Throughput Screening (HTS). However, detergent micelles possess hydrophobic cores that mimic protein binding pockets. If your detergent concentration exceeds

its Critical Micelle Concentration (CMC), the **Fluorescent Red Mega 500** dye will partition into the micelles and fluoresce intensely, destroying your Signal-to-Background (S/B) ratio.

## Detergent Compatibility Matrix

The following data summarizes compatibility based on the dye's TICT mechanism and micelle formation thresholds.

Core Rule: Detergent concentration must remain below the Critical Micelle Concentration (CMC) to avoid non-specific "turn-on" of the fluorophore.

Detergent Class	Specific Detergent	CMC (approx.)	Recommended Max Limit	Compatibility Status	Mechanism of Interference
Non-ionic	NP-40	~0.29 mM (0.02%)	0.01%	High (Preferred)	Tolerated below CMC; suppresses compound aggregation without triggering TICT.
Non-ionic	Tween-20	~0.06 mM (0.007%)	< 0.005%	Low	Low CMC makes it risky; micelles form at very low concentrations, causing high background.
Zwitterionic	CHAPS	~8 mM (0.5%)	0.1%	Medium	Higher CMC allows more flexibility, but can interfere with protein-dye binding kinetics.
Ionic	SDS	~8 mM (0.23%)	Avoid	Incompatible	Denatures the target protein (e.g., HSA), destroying the binding pocket

required for  
the assay.

---

## Troubleshooting Guide (Q&A)

### Section A: Signal & Background Issues

Q1: I am seeing extremely high background fluorescence in my "No Protein" controls. Is the dye degrading? Diagnosis: This is likely the "Micelle Trap" effect, not dye degradation. Root Cause: You are likely using a detergent (e.g., Tween-20 or Triton X-100) above its CMC. The **Fluorescent Red Mega 500** is partitioning into the hydrophobic core of the detergent micelles, which "turns on" the fluorescence just as a protein pocket would. Solution:

- Check the CMC of your detergent.
- Dilute the detergent to 0.5x CMC or switch to NP-40 at 0.01%.
- Validation: Run a buffer-only scan (no protein) with increasing detergent titration. The point where fluorescence spikes is your "Micelle Threshold." Stay below this.

Q2: My assay window (Z-factor) is collapsing when I add my test compounds. Why? Diagnosis: Compound-induced aggregation or Inner Filter Effect (IFE). Root Cause:

- Aggregation: If the detergent is too low, hydrophobic test compounds form aggregates that scatter light or trap the dye.
- IFE:<sup>[2]</sup><sup>[3]</sup> High concentrations of colored compounds absorb the excitation (500 nm) or emission (610 nm) light. Solution:
- Optimization: Titrate NP-40 between 0.001% and 0.01% to find the "sweet spot" (prevents aggregation but doesn't form micelles).
- Red-Shift Advantage: Since **Fluorescent Red Mega 500** emits in the red (~610 nm), it is less susceptible to autofluorescence than green dyes, but IFE is still possible. Correct data using a reference channel if available.

### Section B: Assay Specifics (Displacement Assays)

Q3: In my HSA displacement assay, known binders are not reducing the fluorescence signal (False Negative). Diagnosis: Non-specific hydrophobic binding. Root Cause: The dye might be binding to a secondary site on the protein that is not affected by the drug, OR the detergent micelles are acting as a "sink," keeping the dye fluorescent even when displaced from the protein. Solution:

- Eliminate Micelles: Ensure detergent < CMC.
- Solvent Control: Ensure DMSO concentration is constant (typically <2%). DMSO can also affect the TICT state stability.
- Kinetics: Measure fluorescence immediately after mixing. Some displacements are fast; others require equilibration.

## Visualizing the Mechanism

The following diagram illustrates the TICT Mechanism and the Micelle Trap, explaining why detergent control is critical for **Fluorescent Red Mega 500**.

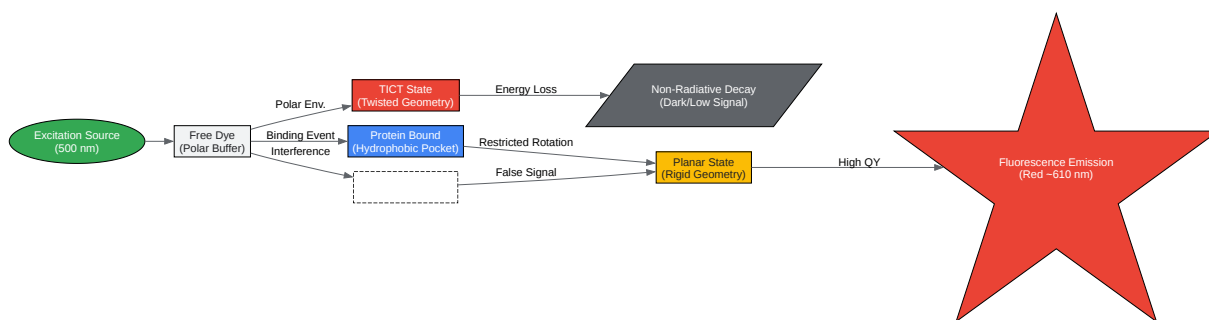

[Click to download full resolution via product page](#)

Caption: Figure 1. The TICT mechanism of **Fluorescent Red Mega 500**.<sup>[1]</sup> In polar buffers, the dye is dark. It fluoresces only when rotation is restricted by a hydrophobic environment (Protein Pocket). Detergent micelles mimic this environment, causing false-positive signals.

## Standardized Protocol: Detergent Optimization Workflow

To validate a new detergent or concentration for your **Fluorescent Red Mega 500** assay, follow this Self-Validating Protocol.

Objective: Determine the Maximum Tolerated Concentration (MTC) of detergent.

- Preparation: Prepare a 2x serial dilution of your detergent in assay buffer (e.g., PBS) ranging from 0.001% to 1.0%. Do not add protein yet.
- Dye Addition: Add **Fluorescent Red Mega 500** to a final concentration of 50–100 nM.
- Readout: Measure Fluorescence Intensity (Ex 500 nm / Em 610 nm).
- Analysis: Plot [Detergent %] vs. Fluorescence.
  - Baseline: You should see a flat, low signal at low concentrations.
  - Inflection Point: The concentration where fluorescence sharply rises is the CMC in your buffer conditions.
- Selection: Choose a working concentration at 50% of the Inflection Point value.
- Verification: Repeat the scan with your target protein (e.g., HSA). Ensure the Signal-to-Background (Protein Signal / Buffer Signal) remains > 5.

## References

- McCallum, M. M., et al. (2014). "A fluorescence-based high throughput assay for the determination of small molecule–human serum albumin protein binding." *Analytical and Bioanalytical Chemistry*. (Describes the use of Red Mega 500 and NP-40 tolerance).
- Yasgar, A., et al. (2016). "Fluorescence polarization assays in high-throughput screening and drug discovery: a review." *Expert Opinion on Drug Discovery*. (Discusses detergent effects on probe displacement assays).
- Sigma-Aldrich / Merck. "Atto-Tec and Mega Labels: Technical Information." (Properties of Large Stokes Shift dyes and TICT mechanisms).

### *Need Custom Synthesis?*

*BenchChem offers custom synthesis for rare earth carbides and specific isotopic labeling.*

*Email: [info@benchchem.com](mailto:info@benchchem.com) or [Request Quote Online](#).*

## Sources

- [1. A fluorescence-based high throughput assay for the determination of small molecule–human serum albumin protein binding - PMC \[pmc.ncbi.nlm.nih.gov\]](#)
- [2. sigmaaldrich.com \[sigmaaldrich.com\]](#)
- [3. Fluorescence polarization assays in high-throughput screening and drug discovery: a review - PMC \[pmc.ncbi.nlm.nih.gov\]](#)
- To cite this document: BenchChem. [Technical Support Center: Fluorescent Red Mega 500 Assay Optimization]. BenchChem, [2026]. [Online PDF]. Available at: [\[https://www.benchchem.com/product/b12058957/docs#technical-support-center-fluorescent-red-mega-500-assay-optimization\]](https://www.benchchem.com/product/b12058957/docs#technical-support-center-fluorescent-red-mega-500-assay-optimization)

---

### Disclaimer & Data Validity:

The information provided in this document is for Research Use Only (RUO) and is strictly not intended for diagnostic or therapeutic procedures. While BenchChem strives to provide accurate protocols, we make no warranties, express or implied, regarding the fitness of this product for every specific experimental setup.

**Technical Support:** The protocols provided are for reference purposes. Unsure if this reagent suits your experiment?

**Need Industrial/Bulk Grade?** [Request Custom Synthesis Quote](#)

## BenchChem

Our mission is to be the trusted global source of essential and advanced chemicals, empowering scientists and researchers to drive progress in science and industry.

### Contact

Address: 3281 E Guasti Rd  
Ontario, CA 91761, United States  
Phone: (601) 213-4426  
Email: [info@benchchem.com](mailto:info@benchchem.com)

Contact our Ph.D. Support Team for a compatibility check