

# Crystallographic & Structural Characterization of Hydroxylammonium Phosphate Adducts

**Author:** BenchChem Technical Support Team. **Date:** May 2026

## Compound of Interest

Compound Name: *hydroxylamine;phosphoric acid*

Cat. No.: *B12057555*

[Get Quote](#)

## Executive Summary

Hydroxylamine phosphate salts (often termed adducts in process literature) represent a critical class of inorganic ionic crystals used as reagents in oxime synthesis (DSM-HPO process) and as energetic stabilizers. While hydroxylamine free base is thermodynamically unstable, its phosphoric acid adducts—specifically Tris(hydroxylammonium) orthophosphate—exhibit enhanced stability due to extensive hydrogen-bonding networks.

This guide provides a rigorous crystallographic characterization of the dominant 3:1 adduct,

, detailing its synthesis, space group symmetry, and supramolecular architecture. It serves as a self-validating protocol for researchers requiring high-purity solid-state forms for drug development or energetic material applications.

## CORE SAFETY DIRECTIVE

CRITICAL HAZARD: Hydroxylamine and its salts are potentially explosive.[1]

- Thermal Instability: Hydroxylammonium phosphate decomposes exothermically above 150°C.

- Incompatibility: Contact with heavy metals (Fe, Cu) or strong oxidizers can catalyze instantaneous decomposition.
- Protocol: All synthesis described below must be performed behind a blast shield with temperature monitoring.

## Chemical Context & Stability

The interaction between hydroxylamine (

) and phosphoric acid (

) does not yield a simple physical adduct but rather well-defined ionic salts. Depending on the stoichiometry, mono-, di-, or tri-basic salts can form. The most crystallographically distinct and commercially relevant form is the Tris(hydroxylammonium) orthophosphate (3:1 salt).

In the solid state, the stability of this adduct is governed by the proton transfer from phosphoric acid to the nitrogen of hydroxylamine, forming the hydroxylammonium cation (

) and phosphate anion (

). This ionic lattice is reinforced by a 3D network of hydrogen bonds, which significantly raises the decomposition temperature compared to the free base.

## Synthesis & Crystallization Protocol

To obtain single crystals suitable for X-ray Diffraction (XRD), a direct neutralization method with strict thermal control is required. This protocol is adapted from the work of Leinemann et al. (2015).[2]

## Reagents

- Hydroxylamine solution (50% w/w in water): High purity, free of metal ions.
- Orthophosphoric acid (85%): Analytical grade.
- Solvent: Deionized water (18.2 MΩ).

## Step-by-Step Methodology

- Stoichiometric Calculation: Target the 3:1 molar ratio.
- Controlled Addition (Exothermic):
  - Place the phosphoric acid solution in a jacketed reactor cooled to 5°C.
  - Add the hydroxylamine solution dropwise. Crucial: Maintain internal temperature . Higher temperatures promote side reactions and degradation.
- Crystallization:
  - Evaporate the resulting clear solution under vacuum at ambient temperature until saturation is reached.
  - Slow Cooling: Transfer the saturated solution to a snap-cap vial. Allow to stand at 15°C.
  - Crystal Growth: Colorless, block-shaped crystals typically form within 48–72 hours.
- Harvesting:
  - Filter crystals and wash with ice-cold mother liquor.
  - Dry under vacuum at room temperature (Do not heat).

## Workflow Visualization

The following diagram outlines the critical path for synthesis, emphasizing safety checkpoints.

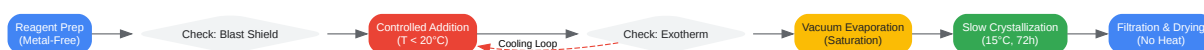

[Click to download full resolution via product page](#)

Figure 1: Synthesis workflow for Tris(hydroxylammonium) orthophosphate with integrated safety loops.

## Crystallographic Architecture

The definitive structural characterization of the 3:1 adduct was resolved using Single Crystal X-Ray Diffraction (SC-XRD). The structure is non-centrosymmetric, which is significant for potential piezoelectric properties, though the primary interest here is structural stability.

## Crystal Data Summary

Parameter	Value
Formula	
Crystal System	Trigonal
Space Group	(No. 161)
Unit Cell a, b	
Unit Cell c	
Volume	
Z (Formula Units)	6
Temperature	170 K (Low temp required for H-atom precision)

Data Source: Leinemann et al., Acta Cryst. [2] E (2015). [2][3][4][5]

## Structural Logic & Hydrogen Bonding

The lattice is constructed from discrete

anions and

cations.

- **Anion Placement:** The phosphorus atom of the orthophosphate anion sits on a 3-fold rotation axis. [6] This symmetry dictates that the phosphate tetrahedron is highly ordered.
- **Cation Placement:** The hydroxylammonium cations occupy general positions surrounding the phosphate core.
- **The H-Bond Network:** This is the stabilizing force.

- N-H...O Interactions: The ammonium head group ( ) acts as a donor to the phosphate oxygens.
- O-H...O Interactions: The hydroxyl group (-OH) of the cation also donates a hydrogen bond to the phosphate oxygen.
- Result: A dense 3D network where every phosphate oxygen accepts multiple hydrogen bonds, effectively "locking" the volatile hydroxylamine species into a rigid ionic lattice.

## Interaction Diagram

The following diagram illustrates the connectivity logic within the unit cell.

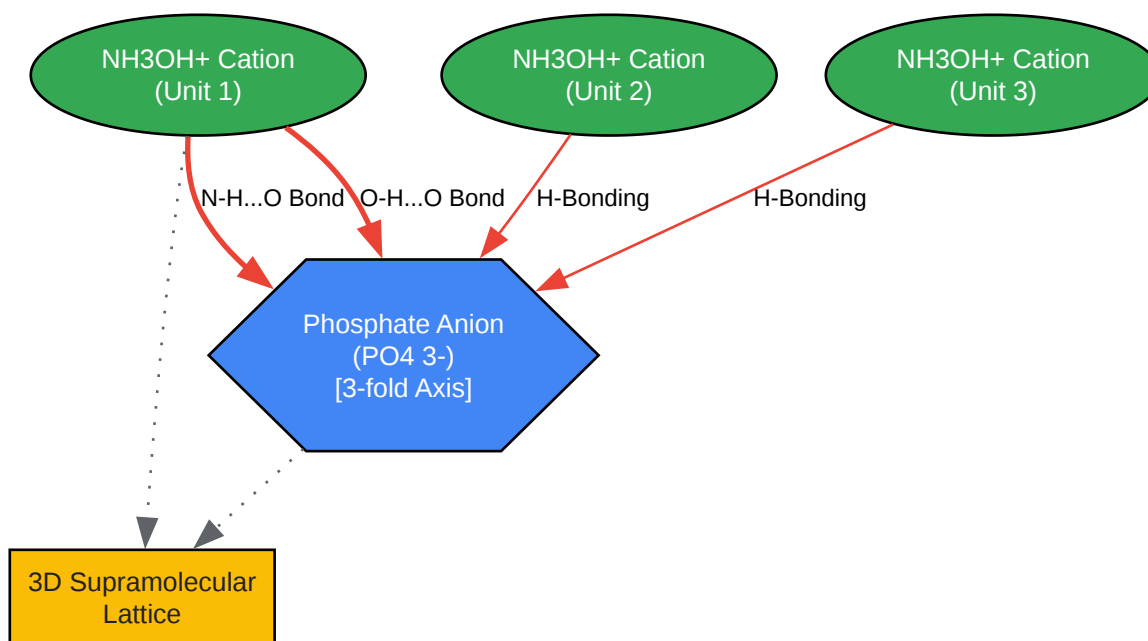

[Click to download full resolution via product page](#)

Figure 2: Supramolecular interaction map showing the hydrogen bonding "glue" between cations and the central phosphate.

## Spectroscopic Corroboration

To validate the synthesis without running a full SC-XRD, researchers should use Vibrational Spectroscopy. The transition from free base to salt is distinct.

- Raman/IR Signatures:
  - Phosphate Modes: Strong bands around ( stretching).
  - Ammonium Modes: Broad absorption in the region indicates the protonated group, distinguishing it from the of the free base.
  - Absence of Free Base: The lack of sharp, isolated stretches typical of volatile amines confirms complete salt formation.

## Applications in Drug Development

While often viewed as an energetic material, hydroxylammonium phosphate has utility in pharmaceutical process chemistry:

- Oximation Reagent: It is a solid-state, weighable source of hydroxylamine for converting ketones to oximes (e.g., in steroid synthesis or the Beckmann rearrangement precursors).
- Safety Profile: Unlike Hydroxylamine Hydrochloride (which releases corrosive HCl gas upon reaction/degradation), the phosphate salt releases mild phosphoric acid, which is often easier to buffer or remove in downstream processing.

## References

- Leinemann, M., Jess, I., Boeckmann, J., & Näther, C. (2015).[2] Crystal structure of tris(hydroxylammonium) orthophosphate.[2][6] Acta Crystallographica Section E: Crystallographic Communications, 71(11), 10-11.[2] [\[Link\]](#)
- Dickens, B. (1969).[6] The crystal structure of hydroxylammonium orthophosphate. Acta Crystallographica Section B: Structural Crystallography and Crystal Chemistry, 25(9).

(Foundational work on related hydroxylammonium salts).

### Need Custom Synthesis?

BenchChem offers custom synthesis for rare earth carbides and specific isotopic labeling.

Email: [info@benchchem.com](mailto:info@benchchem.com) or [Request Quote Online](#).

## Sources

- [1. guidechem.com](https://www.guidechem.com) [[guidechem.com](https://www.guidechem.com)]
- [2. Hydroxylammonium phosphate \(3:1\) | H12N3O7P | CID 10176537 - PubChem](https://pubchem.ncbi.nlm.nih.gov/compound/Hydroxylammonium-phosphate-(3:1)-H12N3O7P) [[pubchem.ncbi.nlm.nih.gov](https://pubchem.ncbi.nlm.nih.gov)]
- [3. researchgate.net](https://www.researchgate.net) [[researchgate.net](https://www.researchgate.net)]
- [4. Synthesis and characterization of methylammonium phosphates as crystalline approximants for anhydrous, low melting phosphate glasses - PMC](https://pubchem.ncbi.nlm.nih.gov/compound/Methylammonium-phosphate) [[pubchem.ncbi.nlm.nih.gov](https://pubchem.ncbi.nlm.nih.gov)]
- [5. Synthesis and crystal structure of 4-fluorobenzylammonium dihydrogen phosphate, \[FC6H4CH2NH3\]H2PO4 - PMC](https://pubchem.ncbi.nlm.nih.gov/compound/4-fluorobenzylammonium-dihydrogen-phosphate) [[pubchem.ncbi.nlm.nih.gov](https://pubchem.ncbi.nlm.nih.gov)]
- [6. Crystal structure of tris\(hydroxylammonium\) orthophosphate - PMC](https://pubchem.ncbi.nlm.nih.gov/compound/Tris(hydroxylammonium)-orthophosphate) [[pubchem.ncbi.nlm.nih.gov](https://pubchem.ncbi.nlm.nih.gov)]
- To cite this document: BenchChem. [Crystallographic & Structural Characterization of Hydroxylammonium Phosphate Adducts]. BenchChem, [2026]. [Online PDF]. Available at: [<https://www.benchchem.com/product/b12057555/docs#crystallographic-structural-characterization-of-hydroxylammonium-phosphate-adducts>]

---

### Disclaimer & Data Validity:

The information provided in this document is for Research Use Only (RUO) and is strictly not intended for diagnostic or therapeutic procedures. While BenchChem strives to provide accurate protocols, we make no warranties, express or implied, regarding the fitness of this product for every specific experimental setup.

**Technical Support:** The protocols provided are for reference purposes. Unsure if this reagent suits your experiment?

**Need Industrial/Bulk Grade?** [Request Custom Synthesis Quote](#)

# BenchChem

Our mission is to be the trusted global source of essential and advanced chemicals, empowering scientists and researchers to drive progress in science and industry.

## Contact

Address: 3281 E Guasti Rd

Ontario, CA 91761, United States

Phone: (601) 213-4426

Email: [info@benchchem.com](mailto:info@benchchem.com)

[Contact our Ph.D. Support Team for a compatibility check](#)