

Technical Support Center: Overcoming Low Ionization Efficiency of Triglycerides in MS

Author: BenchChem Technical Support Team. **Date:** April 2026

Compound of Interest

Compound Name: *Glyceryl tripalmitelaidate*

Cat. No.: *B12056103*

[Get Quote](#)

This technical support center provides researchers, scientists, and drug development professionals with comprehensive troubleshooting guides and frequently asked questions (FAQs) to address the challenges of low ionization efficiency of triglycerides (TGs) in mass spectrometry (MS).

Frequently Asked questions (FAQs)

Q1: Why do triglycerides have low ionization efficiency in mass spectrometry?

Triglycerides are neutral, non-polar lipids, which makes them difficult to ionize using common techniques like electrospray ionization (ESI).[1][2] Unlike polar lipids that readily accept or lose a proton, triglycerides lack easily ionizable functional groups.[1] Consequently, their analysis often results in low sensitivity and poor signal intensity.

Q2: What are the most common ionization techniques for triglyceride analysis?

The most commonly used ionization techniques for TG analysis are Electrospray Ionization (ESI), Atmospheric Pressure Chemical Ionization (APCI), and Matrix-Assisted Laser Desorption/Ionization (MALDI).[2][3]

- ESI is a soft ionization technique well-suited for polar and charged molecules. For triglycerides, ionization is achieved through the formation of adducts with cations.[2]
- APCI is more suitable for less polar to non-polar molecules like triglycerides and is generally less prone to matrix effects than ESI.[2][4]
- MALDI is a soft ionization technique that can be used for a wide range of molecules, including lipids, with minimal fragmentation.[5]

Q3: What are adducts and why are they important for triglyceride analysis?

Adducts are ions formed when a molecule, such as a triglyceride, associates with a cation. In triglyceride analysis, adduct formation is crucial for enhancing ionization efficiency, particularly in ESI.[1][2] Common adducts for triglycerides include ammonium ($[M+NH_4]^+$), sodium ($[M+Na]^+$), and lithium ($[M+Li]^+$) ions.[1][2][6] The choice of adduct can influence sensitivity and fragmentation patterns.[1][7]

Q4: Which adduct is best for my experiment?

The optimal adduct depends on the specific analytical goals:

- Ammonium adducts ($[M+NH_4]^+$) are commonly used in liquid chromatography-mass spectrometry (LC-MS) as they are compatible with typical chromatographic conditions.[1][8]
- Sodium adducts ($[M+Na]^+$) can provide enhanced signal intensity, especially in MALDI.[9][10]
- Lithium adducts ($[M+Li]^+$) are particularly useful for structural elucidation as they can yield more informative fragment ions in tandem MS (MS/MS) experiments.[1][7][11]

Q5: What is ion suppression and how can I mitigate it?

Ion suppression is a phenomenon where the ionization of target analytes is reduced due to the presence of other co-eluting or co-existing molecules in the sample.[12] This is a common issue in lipidomics, where highly abundant and easily ionizable lipids like phospholipids can suppress the signal of less abundant or harder-to-ionize lipids such as triglycerides.[9][12]

To mitigate ion suppression, you can:

- Dilute the sample: This reduces the concentration of interfering molecules.[8]
- Use chromatographic separation: Techniques like liquid chromatography (LC) can separate triglycerides from other lipid classes before they enter the mass spectrometer.[8][12]
- Perform sample prefractionation: Solid-phase extraction (SPE) can be used to isolate different lipid classes prior to analysis.[8]

Troubleshooting Guides

Issue 1: Low Signal Intensity or No Signal in ESI-MS

Probable Cause	Recommended Solution
Poor Adduct Formation	Introduce a mobile phase modifier to promote adduct formation. Ammonium formate or acetate (5-10 mM) is commonly used for ammonium adducts. For sodium or lithium adducts, add the corresponding salts, but be cautious of high concentrations that can suppress the ESI signal.
Ion Suppression	Dilute the sample to a lower total lipid concentration. Utilize liquid chromatography (LC) to separate TGs from more easily ionizable species.[8] Use solid-phase extraction (SPE) for sample prefractionation.[8]
Suboptimal ESI Source Parameters	Systematically optimize source parameters such as spray voltage, sheath gas flow rate, auxiliary gas heater temperature, and capillary temperature.[8][13][14]
Inappropriate Solvent System	Use reversed-phase solvents like water, acetonitrile, and methanol, which are preferable for ESI as they support ion formation.[13]

Issue 2: Poor Signal-to-Noise Ratio in MALDI-MS

Probable Cause	Recommended Solution
Inappropriate Matrix Selection	For TG analysis, matrices such as 2,5-dihydroxybenzoic acid (DHB) and 9-aminoacridine (9-AA) have proven effective.[15] Norharmine has also been reported to increase sensitivity for neutral lipids.[8]
Non-uniform Crystal Formation	Ensure the sample and matrix are thoroughly mixed and allowed to co-crystallize properly on the target plate. The dried-droplet method is a common and effective technique.[8]
Suboptimal Laser Fluence	Adjust the laser energy to the minimum required for a good signal to avoid excessive fragmentation.[2]
Presence of Interfering Substances	High concentrations of salts or other lipids can suppress the TG signal. Consider sample cleanup steps or the use of a matrix that is less susceptible to these effects.[9]

Issue 3: Inconsistent or Multiple Adducts Observed

Probable Cause	Recommended Solution
Presence of Multiple Cations	The sample or mobile phase may contain various cations (e.g., H ⁺ , Na ⁺ , K ⁺ , NH ₄ ⁺), leading to the formation of multiple adducts for the same TG molecule.[8]
Solution 1: Controlled Addition of a Single Adduct-Forming Reagent	To promote the formation of a specific adduct, add the corresponding salt at a concentration that outcompetes other endogenous cations. For example, adding ammonium formate will favor the formation of [M+NH ₄] ⁺ adducts.[8]
Solution 2: Sample Cleanup	Use sample preparation techniques to remove excess salts and other sources of unwanted cations.[13]

Experimental Protocols

Protocol 1: Enhancing Triglyceride Ionization in ESI-MS using Ammonium Formate

This protocol outlines the steps for preparing a triglyceride sample for LC-ESI-MS analysis with enhanced ionization through the formation of ammonium adducts.

Materials:

- Triglyceride-containing sample (e.g., lipid extract)
- Methanol (LC-MS grade)
- Isopropanol (LC-MS grade)
- Ammonium formate
- Ultrapure water
- Vortex mixer
- Centrifuge
- Autosampler vials

Procedure:

- Prepare the Mobile Phase Additive:
 - Prepare a 1 M stock solution of ammonium formate in ultrapure water.
 - For the final mobile phase, add the ammonium formate stock solution to achieve a final concentration of 5-10 mM.
- Sample Preparation:
 - Dissolve the lipid extract in a suitable solvent mixture, such as methanol/isopropanol (1:1, v/v).

- The final concentration of the total lipid extract should be optimized, but a starting point of 10-50 µg/mL is recommended.
- Vortex the sample thoroughly to ensure complete dissolution.
- Centrifuge the sample at high speed (e.g., 14,000 rpm) for 10 minutes to pellet any insoluble material.
- Transfer the supernatant to an autosampler vial for LC-MS analysis.
- LC-MS Analysis:
 - Use a suitable reversed-phase LC column (e.g., C18) for the separation of triglycerides.
 - Set the mass spectrometer to positive ion mode.
 - Monitor for the expected $[M+NH_4]^+$ ions of the target triglycerides.
 - Optimize ESI source parameters (e.g., spray voltage, gas flows, temperatures) to maximize the signal of the ammonium adducts.[\[13\]](#)[\[14\]](#)

Protocol 2: MALDI Sample Preparation for Triglyceride Analysis (Dried-Droplet Method)

This protocol describes a common method for preparing triglyceride samples for MALDI-MS analysis using 2,5-dihydroxybenzoic acid (DHB) as the matrix.[\[8\]](#)

Materials:

- Triglyceride-containing sample
- 2,5-dihydroxybenzoic acid (DHB)
- Acetonitrile (ACN)
- 0.1% Trifluoroacetic acid (TFA) in water
- MALDI target plate

- Pipettes

Procedure:

- Prepare Matrix Solution:
 - Prepare a saturated solution of DHB (e.g., 20 mg/mL) in a suitable solvent, such as a 70:30 (v/v) mixture of ACN and 0.1% TFA in water.[8]
- Prepare Analyte Solution:
 - Dissolve the triglyceride sample in a solvent compatible with the matrix solution (e.g., chloroform or methanol).
- Mix and Spot:
 - Mix the analyte solution and the matrix solution. A common ratio is 1:1 (analyte:matrix).
 - If desired, a cationizing agent (e.g., sodium acetate solution) can be added. A typical ratio would be 1:1:2 (analyte:cationizing agent:matrix).
 - Spot approximately 1 μ L of the final mixture onto the MALDI target plate.
- Dry:
 - Allow the spot to air dry completely at room temperature. The formation of fine, uniform crystals is ideal for good results.
- Analyze:
 - Introduce the target plate into the mass spectrometer for analysis.

Visualizations

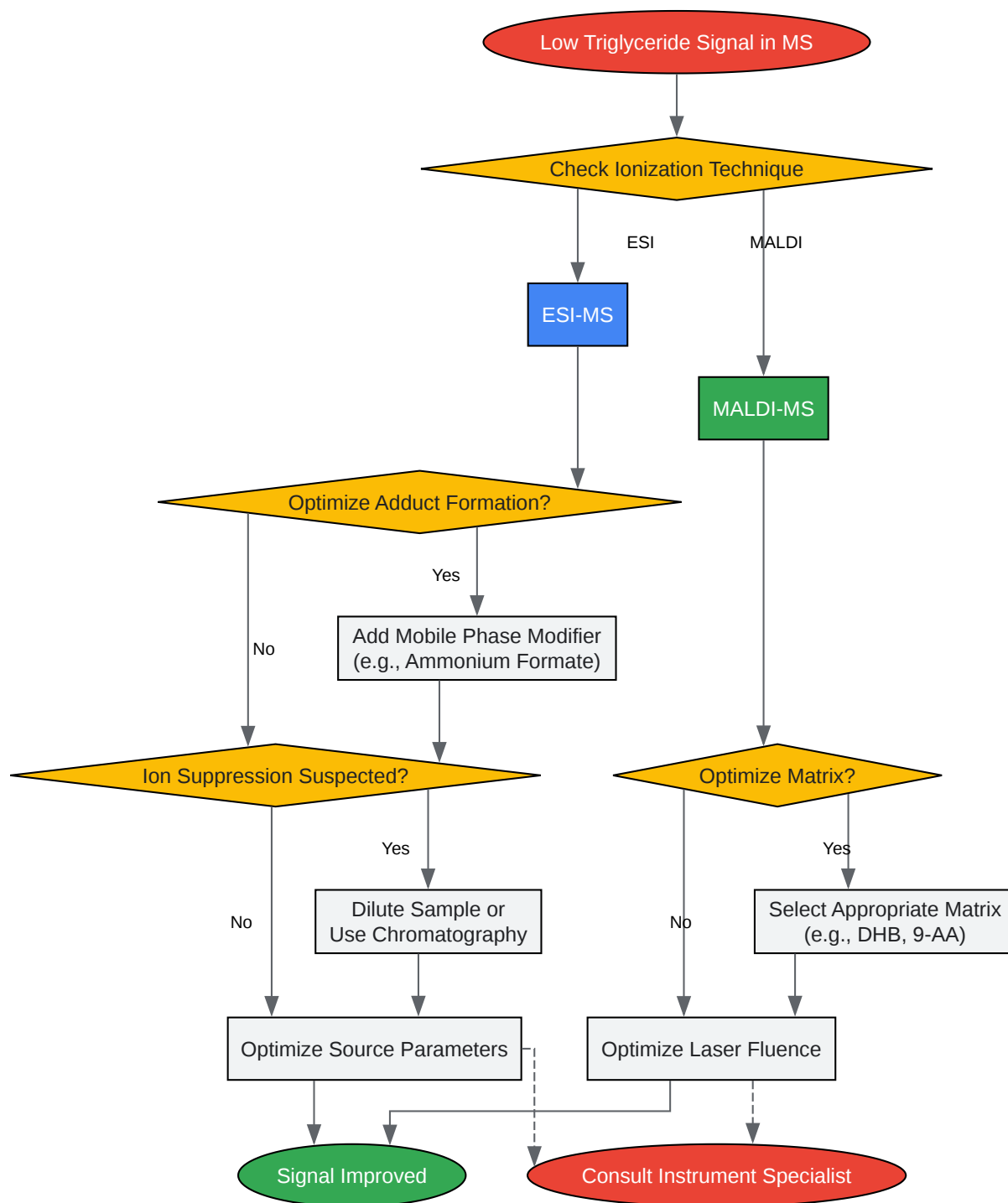

[Click to download full resolution via product page](#)

Caption: Troubleshooting workflow for low triglyceride signal intensity.

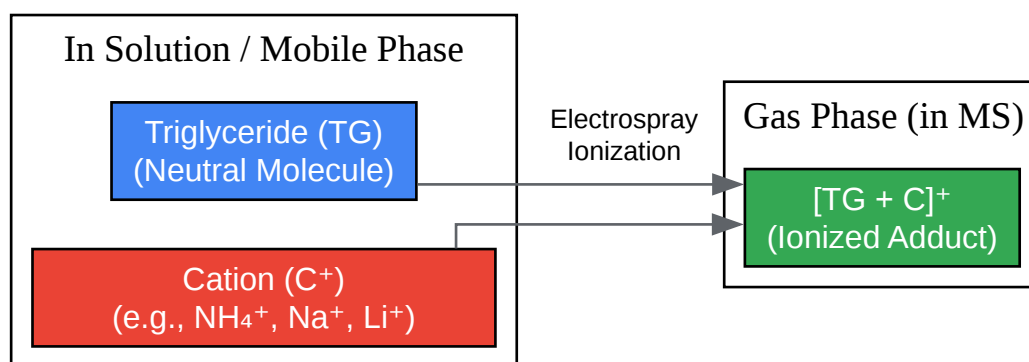

[Click to download full resolution via product page](#)

Caption: Principle of adduct formation for triglyceride ionization.

Need Custom Synthesis?

BenchChem offers custom synthesis for rare earth carbides and specific isotopic labeling.

Email: info@benchchem.com or [Request Quote Online](#).

References

- 1. An Overview of Lipidomic Analysis of Triglyceride Molecular Species in Biological Lipid Extracts - PMC [[pmc.ncbi.nlm.nih.gov](https://pubmed.ncbi.nlm.nih.gov)]
- 2. [benchchem.com](https://www.benchchem.com) [[benchchem.com](https://www.benchchem.com)]
- 3. [researchgate.net](https://www.researchgate.net) [[researchgate.net](https://www.researchgate.net)]
- 4. Analysis of triglycerides using atmospheric pressure chemical ionization mass spectrometry | Semantic Scholar [[semanticscholar.org](https://www.semanticscholar.org)]
- 5. [mdpi.com](https://www.mdpi.com) [[mdpi.com](https://www.mdpi.com)]
- 6. [mdpi.com](https://www.mdpi.com) [[mdpi.com](https://www.mdpi.com)]
- 7. Structural characterization of triacylglycerols as lithiated adducts by electrospray ionization mass spectrometry using low-energy collisionally activated dissociation on a triple stage quadrupole instrument - PubMed [pubmed.ncbi.nlm.nih.gov]
- 8. [benchchem.com](https://www.benchchem.com) [[benchchem.com](https://www.benchchem.com)]
- 9. [verts.columbian.gwu.edu](https://www.verts.columbian.gwu.edu) [[verts.columbian.gwu.edu](https://www.verts.columbian.gwu.edu)]

- [10. Structural Analysis of Triacylglycerols by Using a MALDI-TOF/TOF System with Monoisotopic Precursor Selection - PMC \[pmc.ncbi.nlm.nih.gov\]](#)
- [11. aocs.org \[aocs.org\]](#)
- [12. Extraction, chromatographic and mass spectrometric methods for lipid analysis - PMC \[pmc.ncbi.nlm.nih.gov\]](#)
- [13. elementlabsolutions.com \[elementlabsolutions.com\]](#)
- [14. chromatographyonline.com \[chromatographyonline.com\]](#)
- [15. Analysis of Triglycerides in Cooking Oils Using MALDI-TOF Mass Spectrometry and Principal Component Analysis | Undergraduate Research Conference Proceedings \[publishing.bceIn.ca\]](#)
- To cite this document: BenchChem. [Technical Support Center: Overcoming Low Ionization Efficiency of Triglycerides in MS]. BenchChem, [2026]. [Online PDF]. Available at: [<https://www.benchchem.com/product/b12056103/docs#technical-support-center-overcoming-low-ionization-efficiency-of-triglycerides-in-ms>]

Disclaimer & Data Validity:

The information provided in this document is for Research Use Only (RUO) and is strictly not intended for diagnostic or therapeutic procedures. While BenchChem strives to provide accurate protocols, we make no warranties, express or implied, regarding the fitness of this product for every specific experimental setup.

Technical Support: The protocols provided are for reference purposes. Unsure if this reagent suits your experiment?

Need Industrial/Bulk Grade? [Request Custom Synthesis Quote](#)

BenchChem

Our mission is to be the trusted global source of essential and advanced chemicals, empowering scientists and researchers to drive progress in science and industry.

Contact

Address: 3281 E Guasti Rd

Ontario, CA 91761, United States

Phone: (601) 213-4426

Email: info@benchchem.com

Contact our Ph.D. Support Team for a compatibility check