

Technical Support Center: Optimizing 3-Aminobiphenyl Synthesis

Author: BenchChem Technical Support Team. **Date:** May 2026

Compound of Interest

Compound Name: 3-Aminobiphenyl

CAS No.: 2243-47-2

Cat. No.: B1205854

[Get Quote](#)

Welcome to the Technical Support Center for **3-Aminobiphenyl** synthesis. As a Senior Application Scientist, my goal is to provide you with in-depth, field-proven guidance to overcome common challenges in yield and purity. This guide is structured as a series of frequently asked questions and troubleshooting scenarios, grounded in chemical principles to explain not just the how, but the why, behind each experimental choice.

A Critical Note on Safety

Before beginning any synthesis, it is imperative to recognize that **3-Aminobiphenyl** is a suspected human carcinogen.^{[1][2][3]} All handling and synthesis steps must be performed in a well-ventilated fume hood with appropriate personal protective equipment (PPE), including gloves, safety glasses, and a lab coat. Consult the Safety Data Sheet (SDS) for detailed handling and disposal information.

FAQs: Choosing Your Synthetic Pathway

The optimal route to **3-Aminobiphenyl** depends on starting material availability, scale, and the specific functionalities present on your precursors. The most common industrial and laboratory-

scale syntheses involve palladium-catalyzed cross-coupling reactions or the reduction of a nitro-precursor.[1][4]

Q1: What are the primary methods for synthesizing **3-Aminobiphenyl**?

A1: There are three principal strategies, each with distinct advantages and challenges:

- **Suzuki-Miyaura Coupling:** This palladium-catalyzed reaction couples an aryl boronic acid (or ester) with an aryl halide. For **3-Aminobiphenyl**, this typically involves reacting 3-bromoaniline with phenylboronic acid or 3-aminophenylboronic acid with a halobenzene.[4] It is widely used due to its functional group tolerance and generally high yields.
- **Reduction of 3-Nitrobiphenyl:** This is a classical and often high-yielding method where 3-nitrobiphenyl is reduced to the corresponding amine.[1] This route is straightforward if 3-nitrobiphenyl is readily available.
- **Buchwald-Hartwig Amination:** This reaction forms the C-N bond directly by coupling an aryl halide (e.g., 3-bromobiphenyl) with an ammonia equivalent or a protected amine, followed by deprotection.
- **Ullmann Condensation:** A classical, copper-catalyzed C-N bond formation reaction. While effective, it often requires harsher conditions (higher temperatures) than modern palladium-catalyzed methods.[5][6]

Q2: How do I choose the best method for my project?

A2: Your choice should be guided by precursor availability and reaction sensitivity. The following table summarizes the key considerations for each route.

Synthetic Route	Common Reactants	Key Advantages	Common Challenges
Suzuki-Miyaura Coupling	3-Bromoaniline + Phenylboronic Acid	High functional group tolerance; mild conditions; commercially available catalysts.	Boronic acid instability (protodeboronation, homocoupling); catalyst sensitivity to oxygen.[7][8][9]
Reduction of 3-Nitrobiphenyl	3-Nitrobiphenyl	Often high-yielding and clean; straightforward workup; multiple reducing agents available.	Availability of the nitro-precursor; potential for over-reduction or side reactions with other reducible groups.
Buchwald-Hartwig Amination	3-Bromobiphenyl + Amine Source	Direct C-N bond formation; excellent for complex amine partners.	Requires careful selection of ligand/base combination; can be sensitive to catalyst poisoning.[10]
Ullmann Condensation	3-Iodo- or 3-Bromobiphenyl + Amine	Cost-effective copper catalyst; good alternative for specific substrates where Pd fails.	Requires high temperatures (>150 °C); often needs stoichiometric copper and polar aprotic solvents.[5][11]

Troubleshooting Guide: Palladium-Catalyzed Reactions (Suzuki & Buchwald-Hartwig)

Low yield, no reaction, or the formation of multiple side products are common issues in cross-coupling chemistry. The flowchart below provides a logical path for diagnosing these problems.

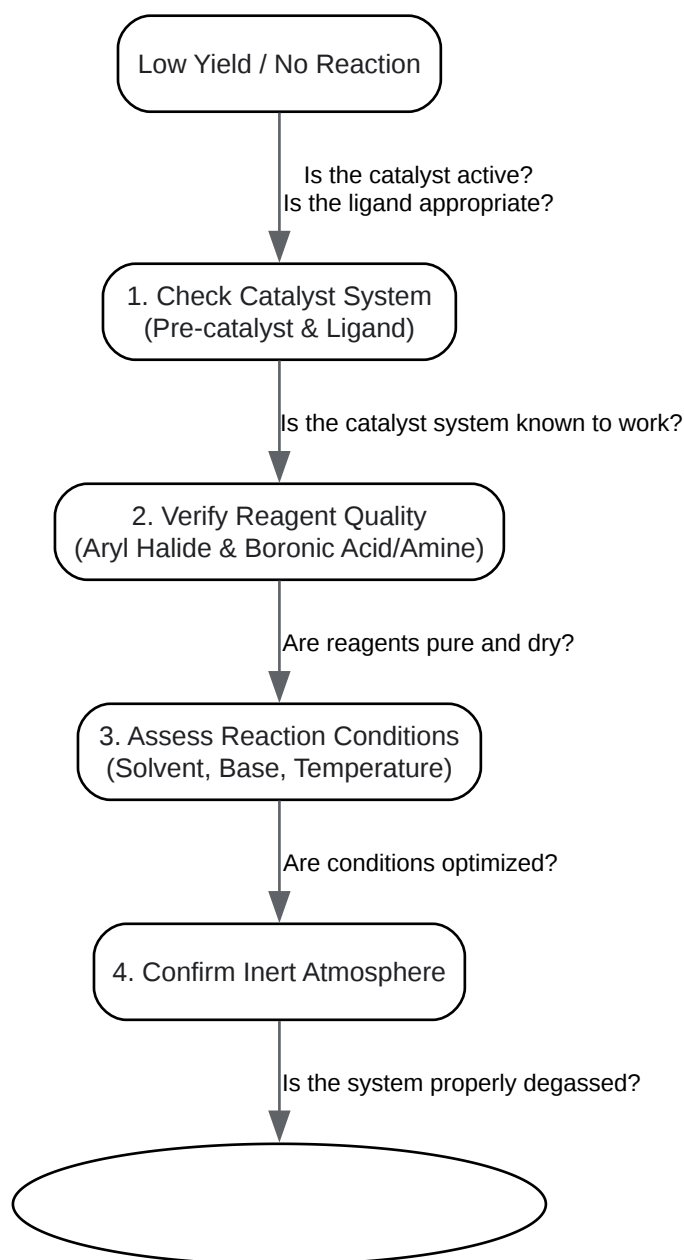

[Click to download full resolution via product page](#)

Caption: Troubleshooting Decision Tree for Cross-Coupling Reactions.

Q3: My Suzuki-Miyaura reaction has a very low yield. What is the most common cause?

A3: The most frequent culprits are boronic acid decomposition and catalyst inactivation.

- Cause (Boronic Acid Decomposition): Phenylboronic acid can undergo two primary side reactions: protodeboronation (replacement of the $-B(OH)_2$ group with hydrogen) and homocoupling (formation of biphenyl).[8][9] Both are often promoted by excess water, oxygen, or excessively high temperatures.[8][9]
- Solution & Protocol:
 - Use High-Purity Reagents: Ensure your boronic acid is dry and has been stored properly. If it appears clumpy or wet, consider drying it under vacuum.
 - Employ Anhydrous Conditions: Use anhydrous solvents. While some water is often necessary for the base to function, excess water promotes protodeboronation.[8] If using a base like K_2CO_3 or K_3PO_4 , consider using the anhydrous powder form.[8]
 - Thoroughly Degas: Oxygen contributes to both boronic acid homocoupling and decomposition of the Pd(0) catalyst.[7][9] Before adding the palladium catalyst, thoroughly degas your reaction mixture by bubbling argon or nitrogen through the solvent for 15-30 minutes or by using several freeze-pump-thaw cycles. Maintain a positive inert gas pressure throughout the reaction.[8]
 - Consider Boronate Esters: If protodeboronation is persistent, switching from a boronic acid to a more stable boronic ester, such as a pinacol (BPin) or MIDA ester, can significantly improve yields.[8]

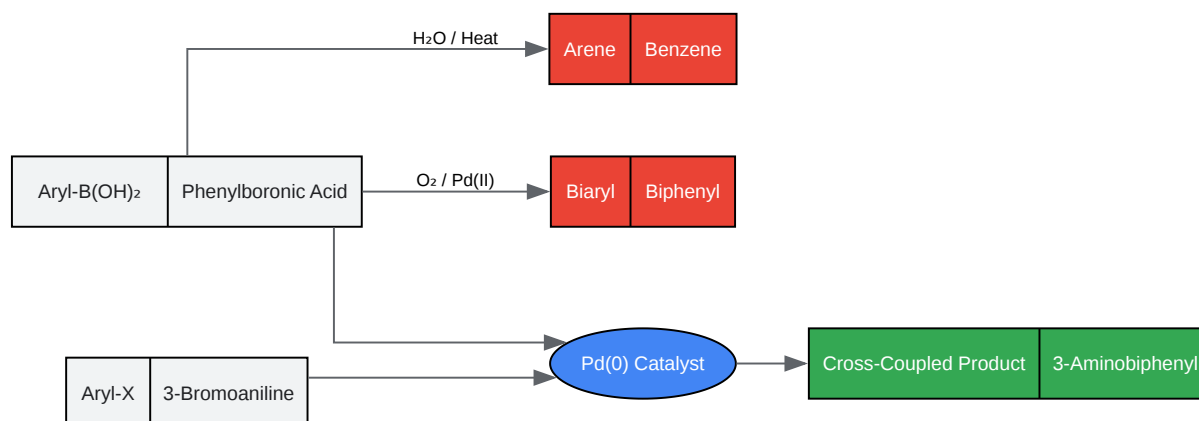

[Click to download full resolution via product page](#)

Caption: Competing reaction pathways for boronic acids in Suzuki coupling.

Q4: My Buchwald-Hartwig amination is sluggish or fails with 3-bromobiphenyl. What should I try?

A4: This often points to a sub-optimal choice of base, ligand, or solvent, which are highly interdependent.[10][12]

- Cause (Poor Reagent Combination): The base's strength and solubility, along with the ligand's steric and electronic properties, are critical for an efficient catalytic cycle.[10] A common issue is the poor solubility of inorganic bases in organic solvents.[10]
- Solution & Protocol:
 - Base Screening: Strong, non-nucleophilic bases are typically required. Sodium tert-butoxide (NaOtBu) is a common and effective choice.[10] If your substrate is sensitive, weaker bases like Cs₂CO₃ or K₃PO₄ can be successful, especially in a more polar solvent like dioxane.[10][13]
 - Ligand Selection: For a relatively unactivated substrate like 3-bromobiphenyl, a bulky, electron-rich phosphine ligand is essential. Buchwald-type ligands such as XPhos or SPhos are excellent starting points.[8][14] They promote the crucial oxidative addition step and stabilize the palladium catalyst.
 - Solvent Choice: Toluene is a robust and common solvent for these reactions.[10][12] Dioxane is another excellent choice, particularly for improving the solubility of inorganic bases.[12][14] Avoid chlorinated solvents, as they can inhibit the catalyst.[10]

Parameter	Common Starting Point	Alternative to Troubleshoot	Rationale
Base	NaOtBu (1.2-1.5 equiv)	K ₃ PO ₄ , Cs ₂ CO ₃	Weaker bases can prevent substrate decomposition.[10]
Ligand	XPhos (2-5 mol%)	SPhos, tBuXPhos	Different ligands have unique steric/electronic properties that can accelerate catalysis for specific substrates. [12][15]
Solvent	Toluene (0.1 - 0.5 M)	Dioxane, 2-MeTHF	Dioxane can improve base solubility; 2-MeTHF is a greener alternative.[10][14]
Temperature	80-110 °C	Screen a range	Excessive heat can degrade the catalyst or substrates.[8]

Troubleshooting Guide: Reduction of 3-Nitrobiphenyl

Q5: My catalytic hydrogenation of 3-nitrobiphenyl is incomplete or shows side products. How can I improve it?

A5: Incomplete reduction is often due to catalyst poisoning or deactivation, while side products can arise from impurities in the starting material.

- **Cause (Catalyst Inactivation):** The palladium-on-carbon (Pd/C) catalyst can be poisoned by sulfur or halide impurities in the starting material or solvent. The catalyst can also lose activity if it is not properly handled (e.g., exposed to air for extended periods).
- **Solution & Protocol:**

- **Verify Starting Material Purity:** Ensure your 3-nitrobiphenyl is free from contaminants. Recrystallization may be necessary.
- **Use High-Quality Catalyst:** Use fresh, high-quality Pd/C catalyst. A typical loading is 1-5 mol% of palladium.
- **Solvent Choice:** Use a solvent like ethanol or ethyl acetate. Ensure the 3-nitrobiphenyl is fully dissolved.
- **Hydrogen Pressure:** While often run at atmospheric pressure, increasing the hydrogen pressure (e.g., to 25-50 psi in a Parr shaker) can significantly increase the reaction rate and drive it to completion.^[16]
- **Monitor Reaction:** Follow the reaction progress by TLC or LC-MS. The disappearance of the starting material spot and the appearance of the more polar amine product spot is a clear indicator.
- **Filtration:** After the reaction, the catalyst must be removed by filtration. Caution: The Pd/C catalyst is pyrophoric, especially when dry and saturated with hydrogen. Do not allow the filter cake to dry in the air. Keep it wet with solvent during and after filtration. Filter through a pad of Celite® to ensure all fine particles are removed.

Experimental Protocols

Protocol 1: Suzuki-Miyaura Synthesis of **3-Aminobiphenyl**

This protocol is a general guideline and should be optimized for your specific setup.

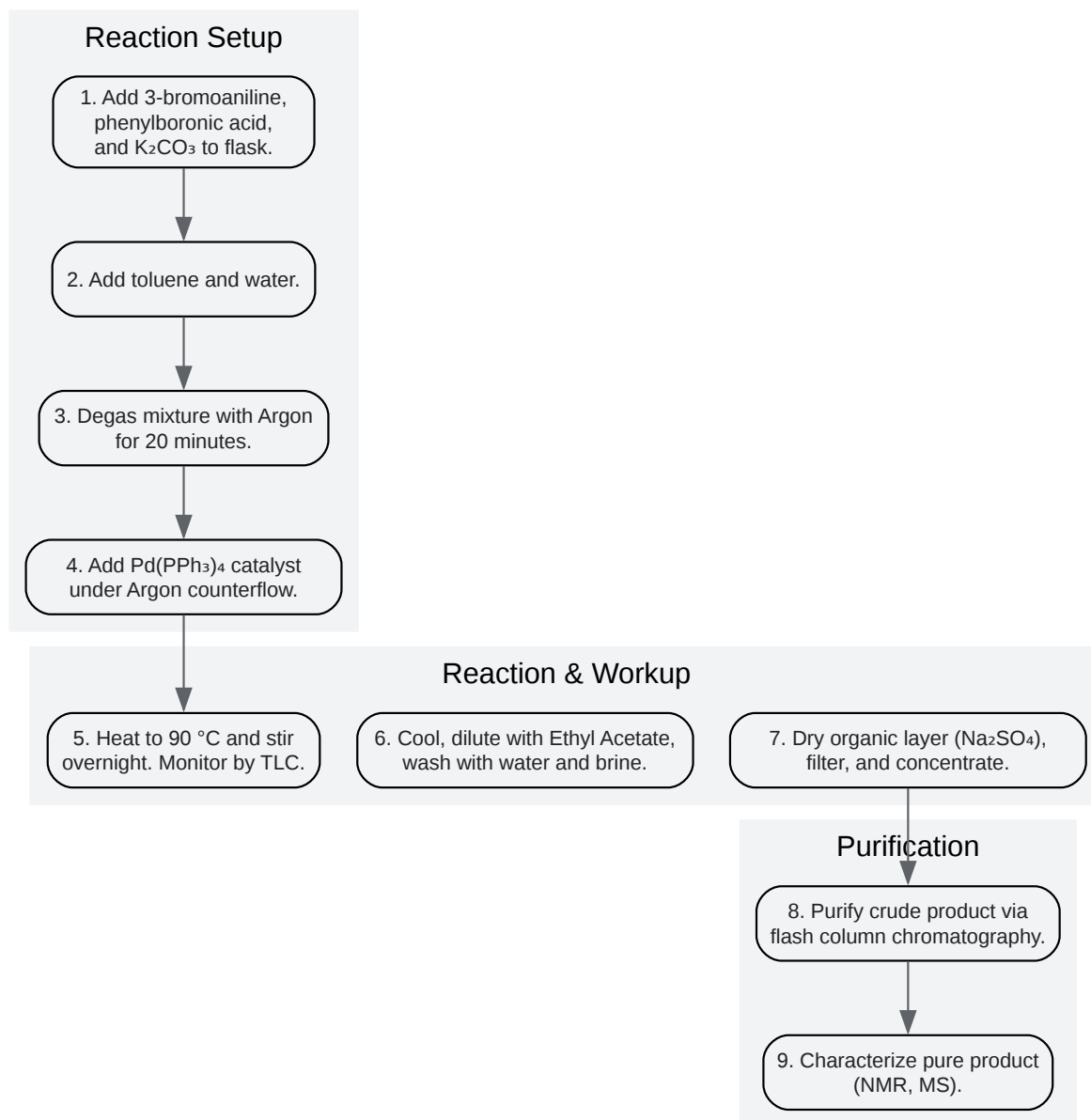

[Click to download full resolution via product page](#)

Caption: General workflow for the Suzuki-Miyaura synthesis of **3-Aminobiphenyl**.

Methodology:

- Preparation: To an oven-dried round-bottom flask equipped with a magnetic stir bar and reflux condenser, add 3-bromoaniline (1.0 equiv.), phenylboronic acid (1.1 equiv.), and potassium carbonate (K_2CO_3 , 2.0 equiv.).
- Inert Atmosphere: Seal the flask with a septum and purge with an inert gas (Argon or Nitrogen) for 10 minutes.
- Reagent Addition: Under an inert atmosphere, add a degassed solvent mixture (e.g., Toluene/Water 4:1, 0.2 M). The mixture should be thoroughly degassed again via sparging with Argon for 15-20 minutes.
- Catalyst Addition: Add the palladium catalyst (e.g., $Pd(PPh_3)_4$, 2-5 mol%) to the flask under a positive flow of inert gas.
- Reaction: Heat the reaction mixture to 80–100 °C and stir vigorously. Monitor the reaction progress by TLC, GC-MS, or LC-MS.[7][8]
- Workup: Once the starting material is consumed, cool the reaction to room temperature. Dilute with ethyl acetate and wash with water, followed by brine. Dry the organic layer over anhydrous sodium sulfate (Na_2SO_4), filter, and concentrate under reduced pressure.[8]
- Purification: Purify the crude residue by flash column chromatography on silica gel (e.g., using a hexane/ethyl acetate gradient) to yield pure **3-aminobiphenyl**.

References

- Syrris. (n.d.). Optimising a Buchwald-Hartwig amination using the ChemSpeed. Retrieved from [\[Link\]](#)
- Wikipedia. (2024). **3-Aminobiphenyl**. Retrieved from [\[Link\]](#)
- ResearchGate. (2014). How can I solve my problem with Suzuki coupling? Retrieved from [\[Link\]](#)
- National Institutes of Health (NIH). (n.d.). 3-Aryl-5-aminobiphenyl Substituted[7][8]
[13]triazolo[4,3-c]quinazolines: Synthesis and Photophysical Properties. Retrieved from [\[Link\]](#)

- Wikipedia. (n.d.). Ullmann condensation. Retrieved from [[Link](#)]
- ACS Publications. (2021). Buchwald–Hartwig Amination of Aryl Halides with Heterocyclic Amines in the Synthesis of Highly Fluorescent Benzodifuran-Based Star-Shaped Organic Semiconductors. Retrieved from [[Link](#)]
- ACS Publications. (2021). Improved Buchwald–Hartwig Amination by the Use of Lipids and Lipid Impurities. Retrieved from [[Link](#)]
- ResearchGate. (n.d.). Optimization of the reaction conditions for the Buchwald-Hartwig... Retrieved from [[Link](#)]
- PubChem. (n.d.). **3-Aminobiphenyl**. Retrieved from [[Link](#)]
- Organic Syntheses. (n.d.). Carbazole, 2-nitro-. Retrieved from [[Link](#)]
- Yoneda Labs. (n.d.). Suzuki-Miyaura cross-coupling: Practical Guide. Retrieved from [[Link](#)]
- ChemBK. (2024). **3-AMINOBIIPHENYL**. Retrieved from [[Link](#)]
- Organic Chemistry Portal. (n.d.). Ullmann Reaction. Retrieved from [[Link](#)]

Need Custom Synthesis?

BenchChem offers custom synthesis for rare earth carbides and specific isotopic labeling.

Email: info@benchchem.com or [Request Quote Online](#).

Sources

- 1. Page loading... [wap.guidechem.com]
- 2. 3-Aminobiphenyl | C12H11N | CID 16717 - PubChem [pubchem.ncbi.nlm.nih.gov]
- 3. chembk.com [chembk.com]
- 4. 3-Aminobiphenyl - Wikipedia [en.wikipedia.org]
- 5. Ullmann condensation - Wikipedia [en.wikipedia.org]
- 6. Ullmann Reaction [organic-chemistry.org]

- [7. pdf.benchchem.com \[pdf.benchchem.com\]](#)
- [8. pdf.benchchem.com \[pdf.benchchem.com\]](#)
- [9. Yoneda Labs \[yonedalabs.com\]](#)
- [10. pdf.benchchem.com \[pdf.benchchem.com\]](#)
- [11. Ullmann Reaction | Thermo Fisher Scientific - TW \[thermofisher.com\]](#)
- [12. pubs.acs.org \[pubs.acs.org\]](#)
- [13. bristol.ac.uk \[bristol.ac.uk\]](#)
- [14. researchgate.net \[researchgate.net\]](#)
- [15. pubs.acs.org \[pubs.acs.org\]](#)
- [16. Organic Syntheses Procedure \[orgsyn.org\]](#)
- To cite this document: BenchChem. [Technical Support Center: Optimizing 3-Aminobiphenyl Synthesis]. BenchChem, [2026]. [Online PDF]. Available at: [\[https://www.benchchem.com/product/b1205854/docs#technical-support-center-optimizing-3-aminobiphenyl-synthesis\]](https://www.benchchem.com/product/b1205854/docs#technical-support-center-optimizing-3-aminobiphenyl-synthesis)

Disclaimer & Data Validity:

The information provided in this document is for Research Use Only (RUO) and is strictly not intended for diagnostic or therapeutic procedures. While BenchChem strives to provide accurate protocols, we make no warranties, express or implied, regarding the fitness of this product for every specific experimental setup.

Technical Support: The protocols provided are for reference purposes. Unsure if this reagent suits your experiment?

Need Industrial/Bulk Grade? [Request Custom Synthesis Quote](#)

BenchChem

Our mission is to be the trusted global source of essential and advanced chemicals, empowering scientists and researchers to drive progress in science and industry.

Contact

Address: 3281 E Guasti Rd

Ontario, CA 91761, United States

Phone: (601) 213-4426

Email: info@benchchem.com

[Contact our Ph.D. Support Team for a compatibility check](#)