

# Minimizing cyclization of 2'-hydroxychalcones to flavanones during synthesis

**Author:** BenchChem Technical Support Team. **Date:** May 2026

## Compound of Interest

Compound Name: 4,2'-Dihydroxy-3,4',6'-  
trimethoxychalcone

CAS No.: 1013916-01-2

Cat. No.: B12049311

[Get Quote](#)

## Technical Support: Minimizing Cyclization of 2'-Hydroxychalcones

### The Core Problem: The Equilibrium Trap

The synthesis of 2'-hydroxychalcones via Claisen-Schmidt condensation is plagued by a competing reversible reaction: the intramolecular Michael addition of the 2'-hydroxyl group onto the

-carbon of the enone system.<sup>[1]</sup> This cyclization yields the corresponding flavanone (colorless), which is often the thermodynamically favored product, while the chalcone (yellow/orange) is the kinetically favored product.

### The Mechanism of Failure

Understanding the enemy is the first step to defeating it. The reaction is driven by the phenoxide ion, which acts as an internal nucleophile.

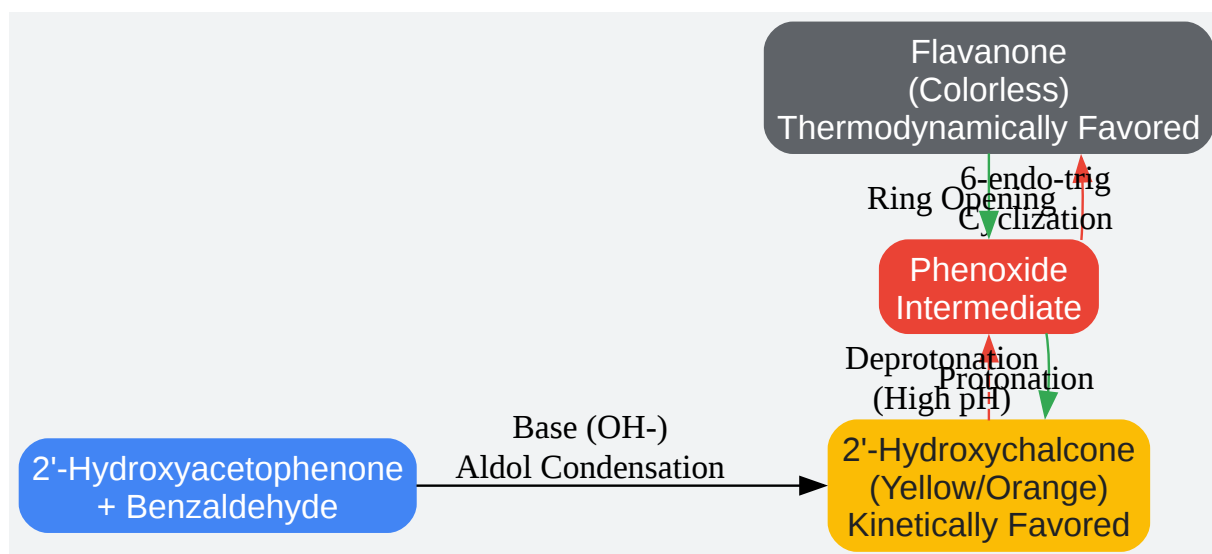

[Click to download full resolution via product page](#)

Figure 1: The reversible equilibrium between chalcone and flavanone. The red path represents the unwanted cyclization.

## Strategy A: The "Gold Standard" (Hydroxyl Protection)[1]

If your synthetic pathway allows it, masking the nucleophile is the only way to guarantee 0% cyclization during the condensation step. The Methoxymethyl (MOM) ether is the preferred protecting group due to its stability in basic conditions and ease of removal.

### Protocol: MOM-Protected Route[1]

Step 1: Protection React 2'-hydroxyacetophenone with MOM-Cl (or MOM-Br) and in Acetone/DMF.[1]

- Checkpoint: The disappearance of the downfield phenolic -OH signal (>12 ppm) in NMR confirms protection.[1]

Step 2: Condensation (Cyclization Impossible) Perform the Claisen-Schmidt condensation with the protected acetophenone.[1]

- Conditions: NaOH/EtOH or KOH/MeOH, Room Temp.
- Why this works: Without the free phenol, the intramolecular Michael addition cannot occur. You can push the reaction to completion without fearing flavanone formation.

Step 3: Deprotection Remove the MOM group under mild acidic conditions.

- Reagent: 3N HCl in Methanol or in DCM.
- Critical Control: Stop the reaction immediately upon deprotection. Prolonged exposure to acid will catalyze cyclization of the now-free chalcone.[1]

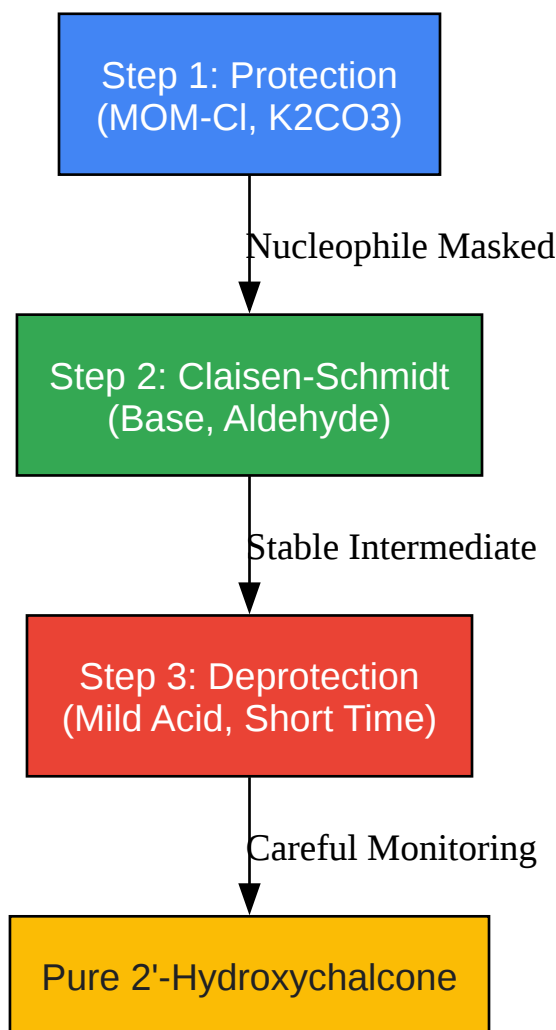

[Click to download full resolution via product page](#)

Figure 2: The protection strategy workflow to bypass the cyclization equilibrium.

## Strategy B: Kinetic Control (Unprotected Route)[1]

If you must synthesize the 2'-hydroxychalcone directly (without protection), you are fighting thermodynamics.[1] You must operate under conditions that favor the kinetic product (chalcone) and precipitate it before it equilibrates to the flavanone.

### Optimized Experimental Parameters

Parameter	Recommended Condition	Scientific Rationale
Temperature	0°C to 5°C	High temps provide the activation energy required for the ring closure (cyclization).[1] Keep it cold.
Base Conc.	High (40-50% NaOH)	High concentrations of base stabilize the chalcone enolate. [1] Weaker bases often lead to incomplete reaction or equilibrium shifts.
Solvent	Ethanol or IPA	Protic solvents stabilize the intermediate. Isopropyl Alcohol (IPA) often improves precipitation of the chalcone salt.
Time	< 4 Hours	Long reaction times allow the system to "relax" into the thermodynamic minimum (Flavanone). Monitor by TLC hourly.

## The "Acidification Trap" (Critical Workup Step)

The most common point of failure is not the reaction, but the workup.

- Pour the reaction mixture into crushed ice/water.

- Slowly acidify with dilute HCl (1M) under vigorous stirring.
- Target pH: 3-4.
- DANGER: Do not drop to pH < 1 or heat the acidic solution. Acid + Heat = Rapid Cyclization.
- Filter the precipitate immediately. Do not let it sit in the mother liquor.

## Troubleshooting & FAQs

Q: My product was yellow in the flask but turned white/colorless after filtration and drying. What happened? A: You likely formed the flavanone. This often happens if the filter cake was not washed thoroughly to remove acid traces, or if you recrystallized from a solvent that was too hot or acidic.

- Fix: Recrystallize from minimal Ethanol/DCM at low temperature. Avoid boiling ethanol if possible.

Q: The yield is good, but the NMR shows a mixture of Chalcone and Flavanone. A: This is the equilibrium manifesting.

- Diagnostic: Look for the characteristic ABX system of the flavanone (dd at ~5.5 ppm, dd at ~3.0 ppm, dd at ~2.8 ppm) vs. the trans-double bond doublets of the chalcone (~14-15 Hz coupling at 7.5-8.0 ppm).[1]
- Fix: You cannot easily separate them by column chromatography as silica gel is slightly acidic and can catalyze further isomerization. Separation requires careful fractional crystallization or preparative HPLC on neutral phases.

Q: My reaction mixture turned black/tarry. A: This indicates oxidation or polymerization, common with electron-rich aldehydes (e.g., vanillin derivatives) in strong base.[1]

- Fix: Perform the reaction under Nitrogen/Argon atmosphere. Add a reducing agent like Sodium Bisulfite during workup to scavenge oxidants.

## References

- Mechanism & Kinetics

- Synthesis and Kinetic Investigations for the Isomerization Process of 2-Hydroxy Chalcone Derivatives. (2020).[2][3][4] ResearchGate.
- Protection Strategy (MOM)
  - Exploring the 2'-Hydroxy-Chalcone Framework for the Development of Dual Antioxidant and Soybean Lipoxygenase Inhibitory Agents. (2016).[2] PMC / NIH.
- Optimization of Unprotected Synthesis
  - An optimized method for synthesis of 2'hydroxy chalcone.[5][6][7] (2013).[5] Asian Journal of Research in Chemistry.
- Ball Mill / Mechanochemical Approaches
  - The Synthesis of 2'-Hydroxychalcones under Ball Mill Conditions and Their Biological Activities. (2024).[6] MDPI.

### *Need Custom Synthesis?*

*BenchChem offers custom synthesis for rare earth carbides and specific isotopic labeling.*

*Email: [info@benchchem.com](mailto:info@benchchem.com) or [Request Quote Online](#).*

## Sources

- [1. eprints.utar.edu.my \[eprints.utar.edu.my\]](https://eprints.utar.edu.my)
- [2. Frontiers | Progress of isolation, chemical synthesis and biological activities of natural chalcones bearing 2-hydroxy-3-methyl-3-butenyl group \[frontiersin.org\]](https://frontiersin.org)
- [3. researchgate.net \[researchgate.net\]](https://researchgate.net)
- [4. researchgate.net \[researchgate.net\]](https://researchgate.net)
- [5. ajrconline.org \[ajrconline.org\]](https://ajrconline.org)
- [6. The Synthesis of 2'-Hydroxychalcones under Ball Mill Conditions and Their Biological Activities | MDPI \[mdpi.com\]](https://mdpi.com)
- [7. Synthesis Chalcones and Their Isomerization into Flavanones and Azaflavanones - PMC \[pmc.ncbi.nlm.nih.gov\]](https://pubmed.ncbi.nlm.nih.gov)

- To cite this document: BenchChem. [Minimizing cyclization of 2'-hydroxychalcones to flavanones during synthesis]. BenchChem, [2026]. [Online PDF]. Available at: [<https://www.benchchem.com/product/b12049311/docs#minimizing-cyclization-of-2-hydroxychalcones-to-flavanones-during-synthesis>]

---

### Disclaimer & Data Validity:

The information provided in this document is for Research Use Only (RUO) and is strictly not intended for diagnostic or therapeutic procedures. While BenchChem strives to provide accurate protocols, we make no warranties, express or implied, regarding the fitness of this product for every specific experimental setup.

**Technical Support:** The protocols provided are for reference purposes. Unsure if this reagent suits your experiment?

**Need Industrial/Bulk Grade?** [Request Custom Synthesis Quote](#)

## BenchChem

Our mission is to be the trusted global source of essential and advanced chemicals, empowering scientists and researchers to drive progress in science and industry.

### Contact

Address: 3281 E Guasti Rd  
Ontario, CA 91761, United States  
Phone: (601) 213-4426  
Email: [info@benchchem.com](mailto:info@benchchem.com)

[Contact our Ph.D. Support Team for a compatibility check](#)