

Technical Support Center: Purity Analysis of Commercial Bergenin Monohydrate

Author: BenchChem Technical Support Team. **Date:** May 2026

Compound of Interest

Compound Name: *Bergenin monohydrate*

CAS No.: 5956-63-8

Cat. No.: B1204147

[Get Quote](#)

Welcome to the technical support center for the purity analysis of commercial **Bergenin monohydrate**. This guide is designed for researchers, scientists, and drug development professionals to provide in-depth technical guidance and troubleshooting for common challenges encountered during the quality control and analysis of **Bergenin monohydrate**.

Frequently Asked Questions (FAQs)

Here, we address some of the most common questions regarding the analysis of **Bergenin monohydrate**.

Q1: What is the most common analytical method for determining the purity of **Bergenin monohydrate**?

A1: The most widely accepted and robust method for the quantitative analysis of **Bergenin monohydrate** is High-Performance Liquid Chromatography (HPLC), particularly Reverse-Phase HPLC (RP-HPLC) with UV detection.^{[1][2][3]} This technique offers excellent resolution, sensitivity, and reproducibility for separating Bergenin from potential impurities. High-

Performance Thin-Layer Chromatography (HPTLC) is also a viable, simpler, and cost-effective alternative for quantification and fingerprinting.[4][5]

Q2: My **Bergenin monohydrate** sample shows poor solubility in the HPLC mobile phase. What should I do?

A2: Bergenin has poor solubility in certain buffers.[6] Methanol is a commonly used solvent for preparing standard and sample solutions of Bergenin.[3][5] If you are experiencing solubility issues with your mobile phase, ensure your sample is fully dissolved in a suitable solvent like methanol before any further dilution with the mobile phase. You can also sonicate the sample solution for a few minutes to aid dissolution.

Q3: What are the expected impurities in a commercial **Bergenin monohydrate** sample?

A3: Commercial Bergenin is often isolated from plant sources, primarily from the *Bergenia* species.[1][7] Therefore, impurities can include other related natural compounds from the plant matrix, such as gallic acid.[1] Degradation products or residual solvents from the extraction and purification process may also be present. It is crucial to use a validated analytical method that can separate Bergenin from these potential impurities.

Q4: My HPLC chromatogram shows a drifting baseline. What could be the cause?

A4: A drifting baseline in HPLC can be caused by several factors. These include an improperly conditioned column, changes in mobile phase composition, temperature fluctuations in the column oven, or a contaminated detector cell. Ensure your column is thoroughly equilibrated with the mobile phase, the mobile phase is well-mixed and degassed, and the column temperature is stable.

Q5: How can I confirm the identity of the Bergenin peak in my chromatogram?

A5: The most reliable method for peak identification is to compare the retention time and UV spectrum of your sample peak with that of a certified reference standard of Bergenin.[1][4] If using a photodiode array (PDA) detector, you can also check the peak purity to ensure no co-eluting impurities are present.[1]

Troubleshooting Guides

This section provides detailed troubleshooting for specific issues you may encounter during HPLC and HPTLC analysis of **Bergenin monohydrate**.

HPLC Analysis Troubleshooting

Problem	Potential Cause(s)	Recommended Solution(s)
No peak or very small peak for Bergenin	<ul style="list-style-type: none"> - Incorrect injection volume or sample concentration. - Detector issue (e.g., lamp off). - Problem with the flow path (e.g., leak, clog). 	<ul style="list-style-type: none"> - Verify sample preparation and injection volume. - Check detector settings and ensure the lamp is on. - Inspect the HPLC system for leaks and check for pressure fluctuations that may indicate a clog.
Split or tailing peaks for Bergenin	<ul style="list-style-type: none"> - Column degradation or contamination. - Incompatible sample solvent with the mobile phase. - Column overloading. 	<ul style="list-style-type: none"> - Flush the column with a strong solvent or replace it if necessary. - Ensure the sample is dissolved in a solvent similar in strength to the mobile phase, or in a weaker solvent. - Reduce the sample concentration or injection volume.
Inconsistent retention times	<ul style="list-style-type: none"> - Fluctuations in mobile phase composition or flow rate. - Temperature instability. - Column aging. 	<ul style="list-style-type: none"> - Ensure the mobile phase is properly mixed and degassed. - Check the pump for consistent flow. - Use a column oven to maintain a stable temperature. - Use a guard column and replace the analytical column when performance degrades.
Extra, unexpected peaks	<ul style="list-style-type: none"> - Sample contamination. - Presence of impurities in the sample. - Ghost peaks from previous injections. 	<ul style="list-style-type: none"> - Use high-purity solvents and handle samples carefully to avoid contamination. - Characterize the impurities if necessary. - Run a blank gradient to identify and eliminate ghost peaks.

HPTLC Analysis Troubleshooting

Problem	Potential Cause(s)	Recommended Solution(s)
Distorted or "smiling" spots	- Uneven solvent front during development.- Edge effects on the HPTLC plate.	- Ensure the developing chamber is properly saturated with the mobile phase vapor.- Avoid spotting samples too close to the edge of the plate.
Rf values are inconsistent	- Changes in mobile phase composition.- Temperature and humidity variations.- Incomplete chamber saturation.	- Prepare fresh mobile phase for each run.- Control the environmental conditions in the lab.- Allow sufficient time for chamber saturation before developing the plate.
Poor resolution between Bergenin and other spots	- Inappropriate mobile phase composition.	- Optimize the mobile phase by trying different solvent ratios or adding modifiers like acetic or formic acid.[4]
Faint spots or low signal intensity	- Insufficient sample concentration.- Incorrect detection wavelength.	- Increase the concentration of the applied sample.- Optimize the detection wavelength based on the UV absorbance maximum of Bergenin (around 272-276 nm).[1][4]

Experimental Protocols

Here are detailed, step-by-step methodologies for the purity analysis of **Bergenin monohydrate** using RP-HPLC.

RP-HPLC Method for Purity Analysis of Bergenin Monohydrate

This protocol is a representative method and may require optimization for your specific instrumentation and sample matrix.

1. Materials and Reagents:

- **Bergenin monohydrate** reference standard ($\geq 98\%$ purity)
- Commercial **Bergenin monohydrate** sample
- HPLC-grade methanol[5]
- HPLC-grade acetonitrile
- HPLC-grade water
- Phosphoric acid or acetic acid (for pH adjustment)[1][2]

2. Instrumentation:

- HPLC system with a gradient pump, autosampler, column oven, and a PDA or UV detector.
- C18 analytical column (e.g., 250 mm x 4.6 mm, 5 μm particle size)

3. Chromatographic Conditions (Example):

- Mobile Phase A: Water with 0.1% phosphoric acid
- Mobile Phase B: Acetonitrile
- Gradient Program: A linear gradient can be optimized. A starting point could be 10-40% B over 20 minutes.
- Flow Rate: 1.0 mL/min
- Column Temperature: 25 $^{\circ}\text{C}$ [2]
- Detection Wavelength: 272 nm[1]
- Injection Volume: 10 μL

4. Preparation of Standard Solution:

- Accurately weigh about 10 mg of Bergenin reference standard.
- Dissolve in methanol in a 10 mL volumetric flask to get a stock solution of 1 mg/mL.[5]
- Prepare working standards of different concentrations (e.g., 10, 25, 50, 100, 200 µg/mL) by diluting the stock solution with methanol.

5. Preparation of Sample Solution:

- Accurately weigh about 10 mg of the commercial **Bergenin monohydrate** sample.
- Dissolve in methanol in a 10 mL volumetric flask.
- Filter the solution through a 0.45 µm syringe filter before injection.

6. Analysis and Data Interpretation:

- Inject the standard solutions to generate a calibration curve.
- Inject the sample solution.
- Identify the Bergenin peak in the sample chromatogram by comparing its retention time with the standard.
- Calculate the purity of the sample using the calibration curve and the peak area of Bergenin in the sample chromatogram.

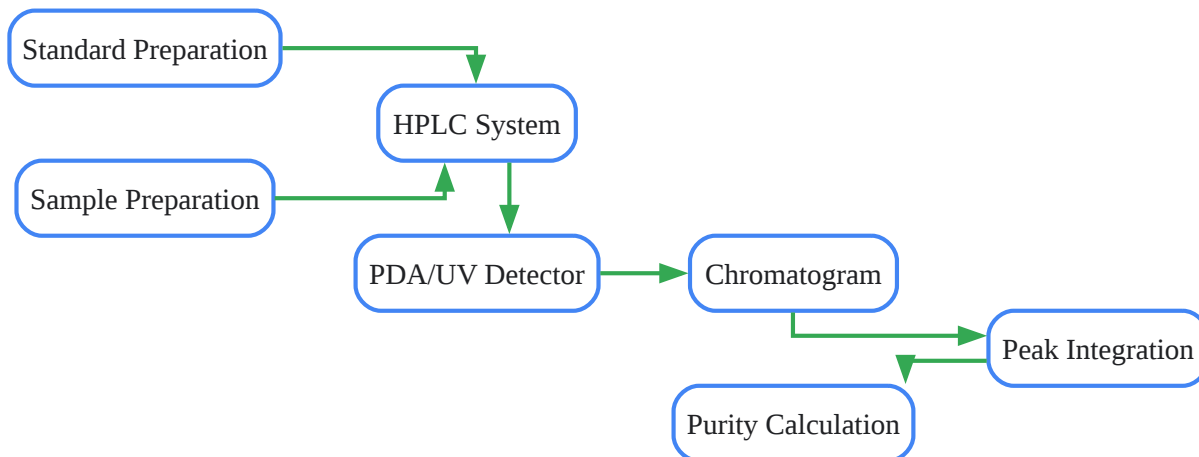

[Click to download full resolution via product page](#)

Caption: A typical workflow for HPLC-based purity analysis.

Visualizing the Logic of Purity Assessment

The following diagram illustrates the logical flow for assessing the purity of a commercial **Bergenin monohydrate** sample.

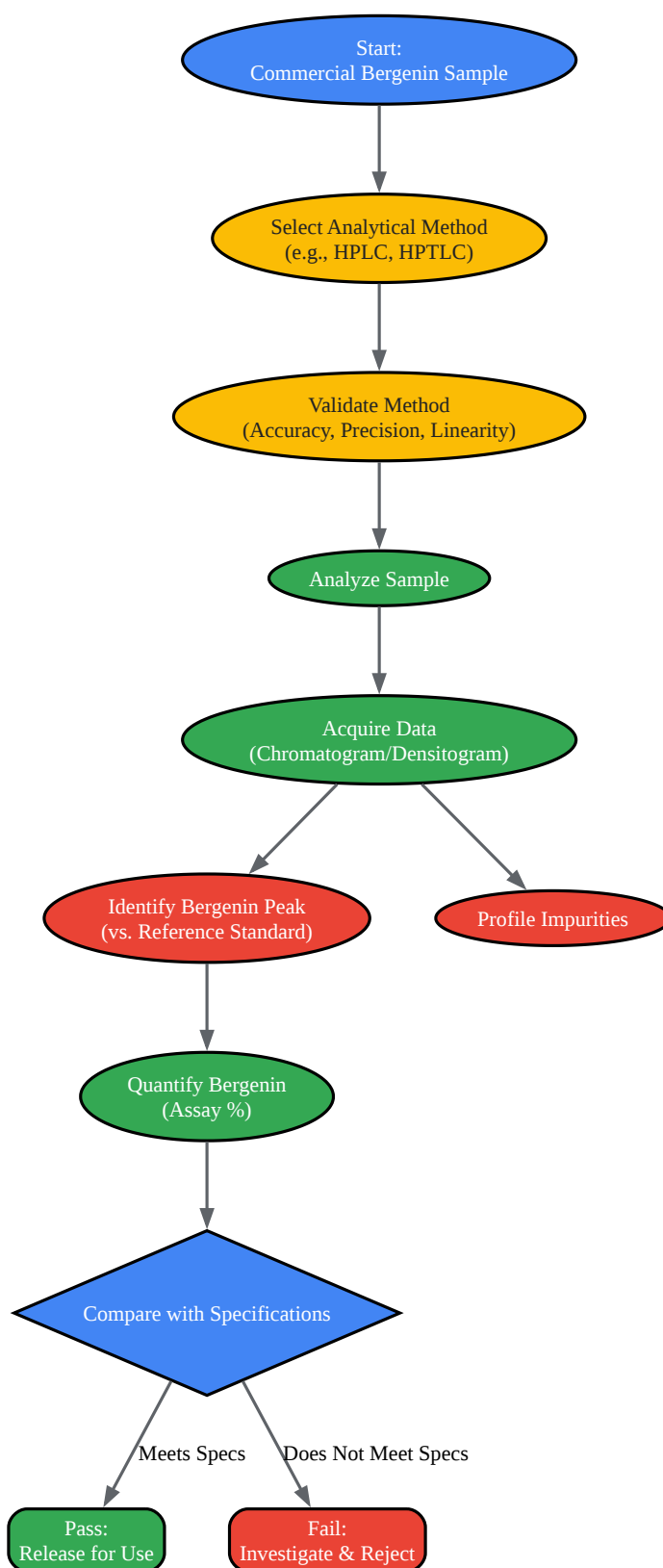

[Click to download full resolution via product page](#)

Caption: Logical workflow for purity assessment of Bergenin.

References

- High-performance liquid chromatographic determination of bergenin in different *Bergenia* species. (2007). ResearchGate. [\[Link\]](#)
- Bergenin determination in different extracts by high-performance thin-layer chromatographic densitometry. (n.d.). PMC - NIH. [\[Link\]](#)
- Use of bergenin as an analytical marker for standardization of the polyherbal formulation containing *Saxifraga ligulata*. (2015). PubMed Central. [\[Link\]](#)
- Synthesis and biological evaluation of bergenin derivatives as new immunosuppressants. (n.d.). Royal Society of Chemistry. [\[Link\]](#)
- Bergenin: Isolation from aqueous extract of *Bergenia ciliata*, antioxidant activity and in silico studies. (2020). Innovations in Pharmaceuticals and Pharmacotherapy. [\[Link\]](#)
- Studies on the physicochemical properties of bergenin. (n.d.). ResearchGate. [\[Link\]](#)
- Determination of Bergenin in Different Parts of *Bergenia ciliata* using a Validated RP-HPLC Method. (n.d.). KoreaScience. [\[Link\]](#)
- Design and Evaluation of pH-Sensitive Nanoformulation of Bergenin Isolated from *Bergenia ciliata*. (2022). MDPI. [\[Link\]](#)

Need Custom Synthesis?

BenchChem offers custom synthesis for rare earth carbides and specific isotopic labeling.

Email: info@benchchem.com or [Request Quote Online](#).

Sources

- [1. researchgate.net \[researchgate.net\]](https://www.researchgate.net)
- [2. Determination of Bergenin in Different Parts of *Bergenia ciliata* using a Validated RP-HPLC Method -Natural Product Sciences | Korea Science \[koreascience.kr\]](https://www.koreascience.kr)

- [3. Design and Evaluation of pH-Sensitive Nanoformulation of Bergenin Isolated from *Bergenia ciliata* \[mdpi.com\]](#)
- [4. Bergenin determination in different extracts by high-performance thin-layer chromatographic densitometry - PMC \[pmc.ncbi.nlm.nih.gov\]](#)
- [5. Use of bergenin as an analytical marker for standardization of the polyherbal formulation containing *Saxifraga ligulata* - PMC \[pmc.ncbi.nlm.nih.gov\]](#)
- [6. researchgate.net \[researchgate.net\]](#)
- [7. innpharmacotherapy.com \[innpharmacotherapy.com\]](#)
- To cite this document: BenchChem. [Technical Support Center: Purity Analysis of Commercial Bergenin Monohydrate]. BenchChem, [2026]. [Online PDF]. Available at: [<https://www.benchchem.com/product/b1204147/docs#technical-support-center-purity-analysis-of-commercial-bergenin-monohydrate>]

Disclaimer & Data Validity:

The information provided in this document is for Research Use Only (RUO) and is strictly not intended for diagnostic or therapeutic procedures. While BenchChem strives to provide accurate protocols, we make no warranties, express or implied, regarding the fitness of this product for every specific experimental setup.

Technical Support: The protocols provided are for reference purposes. Unsure if this reagent suits your experiment?

Need Industrial/Bulk Grade? [Request Custom Synthesis Quote](#)

BenchChem

Our mission is to be the trusted global source of essential and advanced chemicals, empowering scientists and researchers to drive progress in science and industry.

Contact

Address: 3281 E Guasti Rd

Ontario, CA 91761, United States

Phone: (601) 213-4426

Email: info@benchchem.com

Contact our Ph.D. Support Team for a compatibility check