

# Technical Support Center: Optimization of Microwave-Assisted Indole Synthesis

**Author:** BenchChem Technical Support Team. **Date:** May 2026

## Compound of Interest

Compound Name: *1H-indol-3-amine*

CAS No.: 7250-19-3

Cat. No.: B1204680

[Get Quote](#)

Welcome to the technical support center for microwave-assisted indole synthesis. This guide is designed for researchers, scientists, and drug development professionals to provide in-depth troubleshooting, frequently asked questions, and optimized protocols. The indole scaffold is a privileged structure in medicinal chemistry, and microwave-assisted organic synthesis (MAOS) has emerged as a powerful technology to accelerate the discovery of novel indole-based therapeutics by dramatically reducing reaction times and improving yields.<sup>[1][2][3]</sup> This resource is intended to help you navigate the common challenges and unlock the full potential of this technology.

## Troubleshooting Guide: Common Issues and Solutions

Microwave-assisted indole synthesis, while highly efficient, can present unique challenges. This section addresses common problems, their probable causes, and scientifically-grounded solutions to get your reaction back on track.

Problem	Probable Cause(s)	Recommended Solution(s) & Explanation
---------	-------------------	---------------------------------------

<p>Low or No Product Yield</p>	<p>1. Inefficient Microwave Absorption: The reaction mixture may have low polarity, leading to poor coupling with microwave energy.[4] 2. Suboptimal Temperature/Time: The reaction may not have reached the necessary activation energy, or prolonged exposure could be causing degradation.[5] 3. Incorrect Catalyst/Reagent Concentration: The stoichiometry of the catalyst or reactants may be imbalanced. [5][6] 4. Impure Starting Materials: Impurities can lead to side reactions or inhibit the catalyst.[5][6]</p>	<p>1. Solvent/Reagent Modification: a. Add a polar, high-boiling solvent like DMF, DMSO, or NMP to improve energy absorption.[5][7] b. For solvent-free reactions, consider adding a small amount of a microwave-absorbing solid support (e.g., silica, alumina) or an ionic liquid.[8] 2. Systematic Parameter Optimization: a. Incrementally increase the reaction temperature in 10-20°C steps. Microwave heating allows for rapid superheating of solvents above their boiling points in sealed vessels, which can dramatically accelerate reactions.[4][9] b. Monitor the reaction progress at short time intervals (e.g., 5-10 minutes) using TLC to avoid product decomposition.[5][6] 3. Re-evaluate Stoichiometry: a. Perform a catalyst screen to identify the optimal catalyst and loading for your specific substrates.[5][10] b. For reactions like the Bischler synthesis, ensure an excess of the aniline is used. 4. Reagent Purification: a. Use freshly distilled or recrystallized starting materials.[5]</p>
<p>Formation of Multiple Products/Side Reactions</p>	<p>1. Overheating/Hot Spots: Non-uniform heating can lead</p>	<p>1. Improve Heating Uniformity: a. Ensure adequate stirring</p>

to localized high temperatures, promoting side reactions or decomposition.[11] 2. Incorrect Solvent Choice: The solvent may be participating in the reaction or promoting undesired pathways. 3. Catalyst Incompatibility: The chosen acid or metal catalyst may be promoting side reactions like aldol condensations or Friedel-Crafts-type byproducts.[5] during the reaction. b. Reduce the microwave power and increase the reaction time to allow for more even heat distribution. 2. Solvent Screening: a. Test a range of solvents with varying polarities and boiling points.[7] For example, in some palladium-catalyzed reactions, DMF gives superior results compared to DMSO or ACN.[7] 3. Optimize Catalytic System: a. Screen different Brønsted or Lewis acids for Fischer indole synthesis.[5][10] b. For palladium-catalyzed reactions, screen different ligands to improve selectivity. [12]

---

#### Reaction Vessel Leaks or Breaks

1. Excessive Pressure Buildup: Heating a solvent far above its boiling point in a sealed vessel generates significant pressure. [13] 2. Incompatible Vessel Material: The reaction vessel may not be suitable for the temperature and pressure generated.

1. Monitor and Control Pressure: a. Use a microwave reactor with a reliable pressure sensor.[14] b. Reduce the reaction volume or the concentration of volatile reagents. c. Employ "cycled" microwave irradiation (short heating periods followed by cooling) to manage pressure. [14] 2. Use Appropriate Vessels: a. Only use vessels specifically designed for high-pressure microwave synthesis.

---

#### Arcing or Charring

1. Presence of Metal Catalysts: Finely divided metal catalysts (e.g., Pd/C) can sometimes

1. Catalyst Dispersion: a. Ensure the metal catalyst is well-dispersed in the reaction

cause arcing.[15] 2. High Reactant Concentration (Solvent-Free): Concentrated, highly absorbing materials can lead to localized, intense heating and decomposition. mixture. b. Consider using a homogeneous catalyst if arcing is a persistent issue. 2. Modify Reaction Medium: a. For solvent-free reactions, consider adding a microwave-transparent solid support to disperse the reactants and moderate heating.

---

## Frequently Asked Questions (FAQs)

Q1: Why is microwave heating often faster than conventional oil bath heating?

Microwave heating is fundamentally different from conventional heating.[9] In an oil bath, heat is transferred from the outside of the reaction vessel to the solvent and then to the reactants. This is a slow and inefficient process.[16] Microwaves, on the other hand, are a form of electromagnetic energy that directly interacts with polar molecules in the reaction mixture.[17] This interaction, primarily through dipolar polarization and ionic conduction, causes rapid, uniform, and efficient heating of the entire reaction volume simultaneously, leading to a dramatic reduction in reaction times.[9][18]

Q2: What is a "microwave effect"?

The term "microwave effect" refers to reaction rate accelerations that are not solely attributable to the bulk temperature of the reaction.[17] While this is a topic of ongoing scientific discussion, proposed specific microwave effects include the selective heating of polar components, the elimination of hot-surface effects seen in conventional heating, and the generation of localized superheating at the molecular level.[17] These effects can lead to different product distributions or higher yields compared to conventional heating at the same measured bulk temperature.

Q3: How do I choose the right solvent for a microwave-assisted indole synthesis?

The choice of solvent is critical. A good solvent for microwave synthesis should:

- Be polar enough to absorb microwave energy efficiently. Solvents are often categorized as high, medium, or low microwave absorbers.[19]

- Be chemically inert under the reaction conditions.
- Have a sufficiently high boiling point to allow the reaction to reach the required temperature, especially in a sealed vessel where temperatures can far exceed the atmospheric boiling point.[4]

Commonly used high-boiling polar solvents for indole synthesis include DMF, DMSO, NMP, and ethylene glycol.[5][7] In some cases, solvent-free conditions can be highly effective, particularly for the Bischler indole synthesis.[20][21]

Q4: Can I use a domestic microwave oven for these syntheses?

While some early reports on microwave chemistry utilized domestic ovens, it is strongly discouraged for safety and reproducibility reasons. Domestic ovens lack temperature and pressure controls, which can lead to vessel explosions.[11][13] They also have uneven microwave field distribution, resulting in poor reproducibility.[11] Professional, dedicated microwave reactors are equipped with essential safety features and provide precise control over reaction parameters.[22]

Q5: My starting materials are not very polar. How can I effectively heat my reaction?

If your reactants are non-polar and do not absorb microwave energy well, you must use a polar solvent.[19] The polar solvent will absorb the microwave energy and transfer it to the reactants through collisions. Alternatively, for solvent-free reactions, adding a strongly absorbing, inert "sensitizer" or an ionic liquid can facilitate heating.

## Optimized Protocol: Microwave-Assisted Fischer Indole Synthesis

This protocol provides a general method for the synthesis of 2-phenylindole, which can be adapted for other substituted indoles. This reaction is significantly accelerated by microwave irradiation.[1][2]

Reaction: Phenylhydrazine + Acetophenone → 2-Phenylindole

### Materials:

- Phenylhydrazine (1.0 mmol)
- Acetophenone (1.0 mmol)
- Eaton's Reagent (7.7 wt % phosphorus pentoxide in methanesulfonic acid, 2 mL)
- 10 mL microwave process vial with a stir bar
- Dedicated microwave reactor

## Procedure:

- **Reactant Preparation:** In a 10 mL microwave process vial equipped with a magnetic stir bar, combine phenylhydrazine (1.0 mmol) and acetophenone (1.0 mmol).[3]
- **Catalyst Addition:** Carefully add Eaton's reagent (2 mL) to the vial.[3]
- **Microwave Irradiation:** Securely seal the vial and place it in the microwave reactor. Irradiate the mixture at 170°C for 10 minutes with active stirring.[2][3]
- **Work-up:** Once the reaction is complete, allow the vial to cool to room temperature. Quench the reaction by carefully pouring the mixture onto crushed ice in a beaker.
- **Product Isolation:** Neutralize the acidic solution with a saturated aqueous solution of sodium bicarbonate. Extract the product with ethyl acetate (3 x 20 mL). Combine the organic layers, dry over anhydrous sodium sulfate, filter, and concentrate under reduced pressure.
- **Purification:** Purify the crude product by column chromatography on silica gel (eluent: hexane/ethyl acetate) to yield the pure 2-phenylindole.[2]

## Comparative Data:

Method	Catalyst/Solvent	Temperature (°C)	Time	Yield (%)
Microwave	Eaton's Reagent	170	10 min	92
Conventional	Acetic Acid	Reflux	8 hours	75

This data highlights the significant rate enhancement and yield improvement achieved with microwave assistance.<sup>[1]</sup>

## Visualized Workflow and Key Relationships

### General Workflow for Microwave-Assisted Synthesis

The following diagram illustrates the typical workflow for performing a microwave-assisted synthesis experiment, from initial setup to final product analysis.

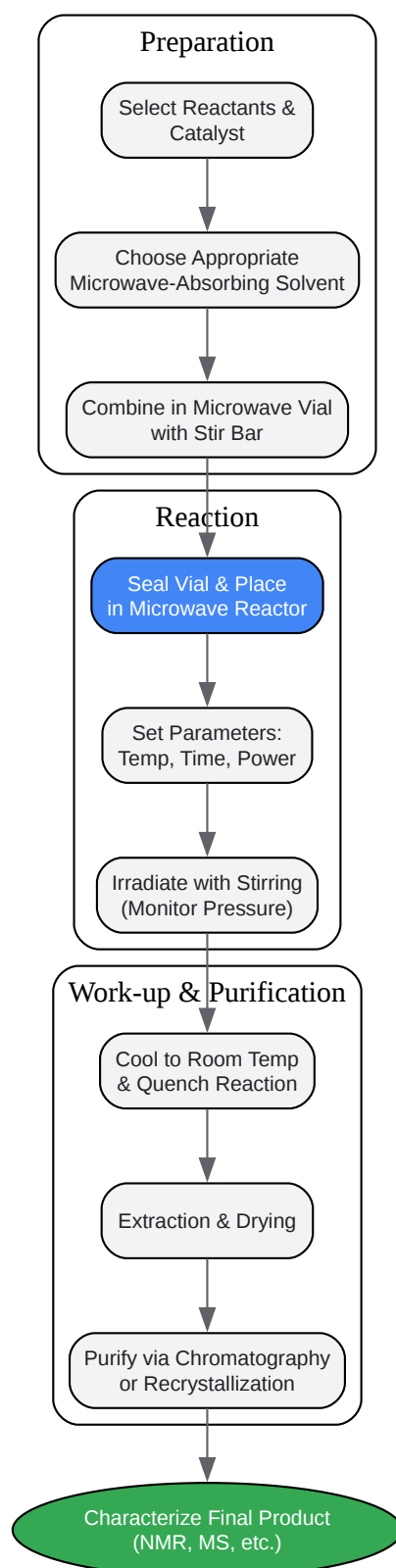

[Click to download full resolution via product page](#)

Caption: General workflow for microwave-assisted organic synthesis.

## Key Parameter Interdependencies in Microwave Synthesis

This diagram illustrates the critical relationship between solvent choice, temperature, pressure, and reaction time in a sealed-vessel microwave experiment.

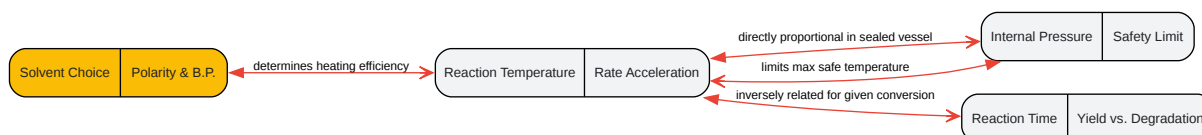

[Click to download full resolution via product page](#)

Caption: Interplay of key parameters in microwave synthesis.

## References

- Microwave-Assisted Synthesis of 2-Methyl-1H-indole-3-carboxylate Derivatives via Pd-Catalyzed Heterocyclization - MDPI. (n.d.).
- Microwaves in Organic Synthetic Chemistry- A Greener Approach to Environmental Protection: An Overview. (n.d.).
- Technical Support Center: Troubleshooting Indole Alkaloid Synthesis - Benchchem. (n.d.).
- Technical Support Center: Optimizing Fischer Indole Synthesis - Benchchem. (n.d.).
- Microwave-Assisted Organic Synthesis: A Green Chemistry Strategy - International Journal of Research in Pharmacy and Allied Science. (n.d.).
- Troubleshooting common issues in Fischer indole synthesis from hydrazones - Benchchem. (n.d.).
- Microwave-Assisted Organic Synthesis: An Eco-Friendly Method of Green Chemistry - PMC. (n.d.).
- Theory of Microwave Heating for Organic Synthesis - CEM Corporation. (n.d.).
- Microwave Chemistry: General Features and Applications. (n.d.).
- Microwave chemistry - Wikipedia. (n.d.).
- Microwave Assisted Organic Synthesis. (n.d.).
- Theory of Microwave Heating for Organic Synthesis - CEM Corporation. (n.d.).
- MICROWAVE ASSISTED SYNTHESIS AND EVALUATION OF INDOLE DERIVATIVES - ijpr. (n.d.).

- A brief review: Microwave assisted organic reaction - Scholars Research Library. (n.d.).
- Microwave Chemistry and its Applications - Research Journal of Pharmaceutical Dosage Forms and Technology. (n.d.).
- Microwave-Assisted Organic Synthesis: An Eco-Friendly Method of Green Chemistry - MDPI. (n.d.).
- Fischer-indole synthesis under microwave irradiation. - ResearchGate. (n.d.).
- Getting Started with Microwave Synthesis - CEM Corporation. (n.d.).
- Microwave-Assisted Synthesis - Georganics. (n.d.).
- Microwave-assisted synthesis of indole. (n.d.).
- MICROWAVE ASSISTED ORGANIC SYNTHESIS: A GREEN CHEMISTRY APPROACH - IJNRD. (2023).
- Microwave-Assisted, Solvent-Free Bischler Indole Synthesis - Organic Chemistry Portal. (n.d.).
- Microwave-assisted synthesis of indole-derivatives via cycloisomerization of 2-alkynylanilines in water without added catalysts, acids, or bases | Request PDF - ResearchGate. (n.d.).
- Microwave-assisted Fischer Indole Synthesis of 1,2,3,4-tetrahydrocarbazole using Pyridinium-based Ionic Liquids - ResearchGate. (n.d.).
- HFIP-Promoted Bischler Indole Synthesis under Microwave Irradiation - MDPI. (2018).
- Bischler–Möhlau indole synthesis - Wikipedia. (n.d.).
- A facile access to substituted indoles utilizing palladium catalyzed annulation under microwave enhanced conditions - ResearchGate. (n.d.).
- Microwave-Assisted Synthesis of Substituted Indoles: Application Notes and Protocols - Benchchem. (n.d.).
- A microwave-assisted facile regioselective Fischer indole synthesis and antitubercular evaluation of novel 2-aryl-3,4-dihydro-2H-thieno[3,2-b]indoles - PubMed. (2009).
- Synthesis of Indoles by Palladium-Catalyzed Reductive Cyclization of  $\beta$ -Nitrostyrenes with Phenyl Formate as a CO Surrogate - MDPI. (n.d.).
- Application of Microwave Synthesizer in the Synthesis of 4-Hydroxy Indole a Pharmaceutically Important Intermediate of Pindolol - Acta Scientific. (2022).
- Bischler Indole Synthesis under Microwave Irradiation: A Solvent-Free Synthesis of 2-Arylindoles - Sciforum. (n.d.).
- A Continuous-Flow Microwave Reactor for Conducting High-Temperature and High-Pressure Chemical Reactions - ACS Publications. (n.d.).
- HFIP-Promoted Bischler Indole Synthesis under Microwave Irradiation - PMC - NIH. (n.d.).
- Application Notes & Protocols: Microwave-Assisted Synthesis of Indole Derivatives - Benchchem. (n.d.).

- Synthesis of indoles, indolines, and carbazoles via palladium-catalyzed C H activation. (2021).
- A Microreactor for Microwave-Assisted Capillary (Continuous Flow) Organic Synthesis | Journal of the American Chemical Society - ACS Publications. (n.d.).
- Full article: Recent advances in the green synthesis of indole and its derivatives using microwave irradiation and the role of indole moiety in cancer - Taylor & Francis Online. (2024).
- Problems with Fischer indole synthesis : r/Chempros - Reddit. (2021).
- Indoles Indoles are very commonly encountered in nature and many, many individual examples which have biological implications. Be. (n.d.).
- Why Do Some Fischer Indolizations Fail? - PMC - NIH. (n.d.).

### Need Custom Synthesis?

BenchChem offers custom synthesis for rare earth carbides and specific isotopic labeling.

Email: [info@benchchem.com](mailto:info@benchchem.com) or [Request Quote Online](#).

## Sources

- 1. [ijrpr.com](#) [ijrpr.com]
- 2. [benchchem.com](#) [benchchem.com]
- 3. [benchchem.com](#) [benchchem.com]
- 4. [rjpdft.com](#) [rjpdft.com]
- 5. [benchchem.com](#) [benchchem.com]
- 6. [benchchem.com](#) [benchchem.com]
- 7. [mdpi.com](#) [mdpi.com]
- 8. [researchgate.net](#) [researchgate.net]
- 9. Theory of Microwave Heating for Organic Synthesis [cem.com]
- 10. [benchchem.com](#) [benchchem.com]
- 11. [ijrpal.com](#) [ijrpal.com]
- 12. [researchgate.net](#) [researchgate.net]
- 13. [ijnrd.org](#) [ijnrd.org]

- [14. goons.web.elte.hu \[goons.web.elte.hu\]](https://goons.web.elte.hu)
- [15. tetrazolelover.at.ua \[tetrazolelover.at.ua\]](https://tetrazolelover.at.ua)
- [16. scholarsresearchlibrary.com \[scholarsresearchlibrary.com\]](https://scholarsresearchlibrary.com)
- [17. Microwave chemistry - Wikipedia \[en.wikipedia.org\]](https://en.wikipedia.org)
- [18. Microwave-Assisted Organic Synthesis: An Eco-Friendly Method of Green Chemistry - PMC \[pmc.ncbi.nlm.nih.gov\]](https://pubmed.ncbi.nlm.nih.gov)
- [19. Getting Started with Microwave Synthesis \[cem.com\]](https://cem.com)
- [20. Microwave-Assisted, Solvent-Free Bischler Indole Synthesis \[organic-chemistry.org\]](https://organic-chemistry.org)
- [21. sciforum.net \[sciforum.net\]](https://sciforum.net)
- [22. actascientific.com \[actascientific.com\]](https://actascientific.com)
- To cite this document: BenchChem. [Technical Support Center: Optimization of Microwave-Assisted Indole Synthesis]. BenchChem, [2026]. [Online PDF]. Available at: [\[https://www.benchchem.com/product/b1204680/docs#technical-support-center-optimization-of-microwave-assisted-indole-synthesis\]](https://www.benchchem.com/product/b1204680/docs#technical-support-center-optimization-of-microwave-assisted-indole-synthesis)

---

#### Disclaimer & Data Validity:

The information provided in this document is for Research Use Only (RUO) and is strictly not intended for diagnostic or therapeutic procedures. While BenchChem strives to provide accurate protocols, we make no warranties, express or implied, regarding the fitness of this product for every specific experimental setup.

**Technical Support:** The protocols provided are for reference purposes. Unsure if this reagent suits your experiment?

**Need Industrial/Bulk Grade?** [Request Custom Synthesis Quote](#)

# BenchChem

Our mission is to be the trusted global source of essential and advanced chemicals, empowering scientists and researchers to drive progress in science and industry.

## Contact

Address: 3281 E Guasti Rd

Ontario, CA 91761, United States

Phone: (601) 213-4426

Email: [info@benchchem.com](mailto:info@benchchem.com)

[Contact our Ph.D. Support Team for a compatibility check](#)