

# Application Notes and Protocols for Phaeantharine Extraction and Purification

**Author:** BenchChem Technical Support Team. **Date:** April 2026

## Compound of Interest

Compound Name: *Phaeantharine*

CAS No.: 27670-80-0

Cat. No.: B1203911

[Get Quote](#)

For Researchers, Scientists, and Drug Development Professionals

## Introduction

**Phaeantharine** is a quaternary bisbenzylisoquinoline alkaloid found in the plant species *Phaeanthus ebracteolatus*. This class of compounds has garnered significant interest within the scientific community due to a wide range of potential therapeutic applications, including anti-inflammatory, antimicrobial, and cytotoxic activities. The effective isolation and purification of **Phaeantharine** are critical steps for further pharmacological investigation and drug development.

These application notes provide a comprehensive overview of the techniques and methodologies for the extraction and purification of **Phaeantharine**. While specific quantitative data for **Phaeantharine** is not extensively available in public literature, this document outlines representative protocols and data based on the extraction and purification of similar bisbenzylisoquinoline alkaloids.

# Extraction of Phaeantharine from Phaeanthus ebracteolatus

The extraction of **Phaeantharine** from its natural source, the bark or other parts of *Phaeanthus ebracteolatus*, typically involves an initial solvent extraction followed by an acid-base liquid-liquid partitioning to isolate the alkaloid fraction.

## Experimental Protocol: Solvent Extraction and Acid-Base Partitioning

This protocol describes a standard method for the initial extraction and isolation of the crude alkaloid mixture containing **Phaeantharine**.

Materials:

- Dried and powdered bark of *Phaeanthus ebracteolatus*
- Methanol (reagent grade)
- Chloroform (reagent grade)
- 2% Sulfuric acid ( $\text{H}_2\text{SO}_4$ )
- Concentrated ammonium hydroxide ( $\text{NH}_4\text{OH}$ )
- Sodium sulfate (anhydrous)
- Rotary evaporator
- Separatory funnel (2 L)
- Filter paper and funnel
- pH meter or pH indicator strips

Procedure:

- Maceration:

- Macerate 1 kg of dried, powdered bark of *Phaeanthus ebracteolatus* with 5 L of methanol at room temperature for 48 hours with occasional stirring.
- Filter the extract through filter paper.
- Repeat the maceration process twice more with fresh methanol.
- Combine the methanolic extracts.
- Concentration:
  - Concentrate the combined methanolic extract under reduced pressure using a rotary evaporator at a temperature not exceeding 50°C to obtain a viscous residue.
- Acid-Base Extraction:
  - Dissolve the residue in 1 L of 2% sulfuric acid.
  - Filter the acidic solution to remove any insoluble material.
  - Transfer the acidic aqueous solution to a 2 L separatory funnel and wash with 500 mL of chloroform to remove non-alkaloidal compounds. Repeat the washing twice.
  - Carefully adjust the pH of the aqueous layer to approximately 9-10 by the slow addition of concentrated ammonium hydroxide. Monitor the pH using a pH meter or indicator strips.
  - Extract the now alkaline aqueous solution with 500 mL of chloroform. Repeat the extraction three times.
  - Combine the chloroform extracts.
- Drying and Final Concentration:
  - Dry the combined chloroform extract over anhydrous sodium sulfate for at least 2 hours.
  - Filter the dried extract and concentrate it to dryness under reduced pressure using a rotary evaporator to yield the crude alkaloid extract.

## Data Presentation: Representative Extraction Yields

The following table presents representative yields for the extraction of bisbenzylisoquinoline alkaloids from plant material, which can be considered indicative for **Phaeantharine** extraction.

Plant Material	Starting Weight (kg)	Crude Alkaloid Extract Yield (g)	Yield (%)
Phaeanthus ebracteolatus (bark)	1.0	15.0	1.5
Stephania tetrandra (root)	1.0	20.0	2.0
Cyclea barbata (leaves)	1.0	12.5	1.25

## Purification of Phaeantharine

The crude alkaloid extract contains a mixture of different alkaloids and other impurities. Further purification is necessary to isolate **Phaeantharine**. Chromatographic techniques are the most effective methods for this purpose. As **Phaeantharine** is a quaternary alkaloid, pH-zone-refining counter-current chromatography (CCC) is a particularly suitable advanced purification technique.

## Experimental Protocol: Purification by Column Chromatography and Preparative HPLC

This protocol outlines a two-step purification process using column chromatography followed by preparative High-Performance Liquid Chromatography (HPLC).

Materials:

- Crude alkaloid extract
- Silica gel (for column chromatography, 70-230 mesh)
- Solvent system for column chromatography (e.g., Chloroform:Methanol gradient)

- Preparative HPLC system with a suitable column (e.g., C18)
- Solvent system for preparative HPLC (e.g., Acetonitrile:Water with trifluoroacetic acid)
- Thin Layer Chromatography (TLC) plates (silica gel 60 F<sub>254</sub>)
- Dragendorff's reagent for alkaloid visualization
- Fraction collector
- Freeze-dryer or rotary evaporator

#### Procedure:

- Silica Gel Column Chromatography (Initial Purification):
  - Prepare a silica gel column (e.g., 5 cm diameter, 50 cm length) packed in chloroform.
  - Dissolve the crude alkaloid extract in a minimal amount of chloroform and adsorb it onto a small amount of silica gel.
  - Load the dried, adsorbed sample onto the top of the column.
  - Elute the column with a gradient of increasing methanol in chloroform (e.g., starting from 100% chloroform to 90:10 chloroform:methanol).
  - Collect fractions (e.g., 20 mL each) and monitor the separation using TLC. Spot the fractions on a TLC plate, develop in a suitable solvent system (e.g., chloroform:methanol 95:5), and visualize the spots by spraying with Dragendorff's reagent.
  - Combine the fractions containing the major alkaloid spot corresponding to **Phaeantharine**.
  - Concentrate the combined fractions to dryness.
- Preparative HPLC (Final Purification):
  - Dissolve the partially purified extract from the column chromatography step in the mobile phase for HPLC.

- Inject the sample into the preparative HPLC system.
- Perform the separation using a C18 column with a suitable gradient of acetonitrile in water (both containing 0.1% trifluoroacetic acid).
- Monitor the elution profile using a UV detector at an appropriate wavelength (e.g., 280 nm).
- Collect the peak corresponding to **Phaeantharine**.
- Desalt the collected fraction if necessary and remove the solvent by freeze-drying or rotary evaporation to obtain pure **Phaeantharine**.

## Data Presentation: Representative Purification Efficiency

The following table illustrates the expected purity at each stage of the purification process for a bisbenzylisoquinoline alkaloid.

Purification Step	Starting Purity (%)	Final Purity (%)	Recovery (%)
Column Chromatography	~10-20	~70-80	~60
Preparative HPLC	~70-80	>98	~85

## Structure and Identity Confirmation

The identity and purity of the isolated **Phaeantharine** should be confirmed using spectroscopic methods.

- Mass Spectrometry (MS): To determine the molecular weight and fragmentation pattern.
- Nuclear Magnetic Resonance (NMR) Spectroscopy:  $^1\text{H}$  and  $^{13}\text{C}$  NMR to elucidate the chemical structure.

While specific spectral data for **Phaeantharine** is not readily available, researchers should compare their obtained spectra with published data for closely related bisbenzylisoquinoline

alkaloids for structural confirmation.

## Potential Signaling Pathways of Phaeantharine

Direct studies on the signaling pathways modulated by **Phaeantharine** are limited. However, based on the known activities of other bisbenzylisoquinoline alkaloids, it is plausible that **Phaeantharine** may exert its biological effects through similar mechanisms.

## Inhibition of Pro-inflammatory Signaling Pathways

Many bisbenzylisoquinoline alkaloids have demonstrated potent anti-inflammatory effects by inhibiting key signaling pathways involved in the inflammatory response.

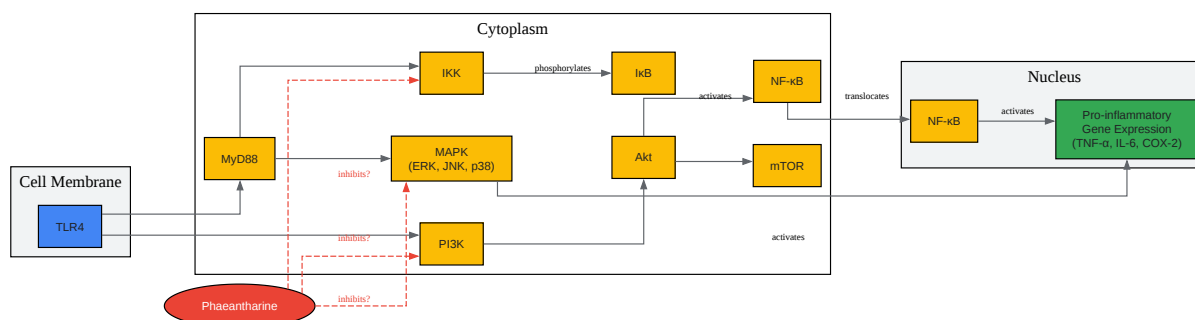

[Click to download full resolution via product page](#)

Caption: Potential inhibition of pro-inflammatory signaling pathways by **Phaeantharine**.

Bisbenzylisoquinoline alkaloids have been shown to inhibit the activation of Nuclear Factor-kappa B (NF-κB), a key transcription factor that regulates the expression of numerous pro-inflammatory genes. This inhibition can occur through the suppression of IκB kinase (IKK) activity. Furthermore, these compounds may also modulate the Mitogen-Activated Protein

Kinase (MAPK) and the Phosphatidylinositol 3-kinase (PI3K)/Akt/mTOR signaling pathways, which are also crucial in inflammation and cell survival.

## Experimental Workflow

The following diagram illustrates the overall workflow for the extraction, purification, and characterization of **Phaeantharine**.

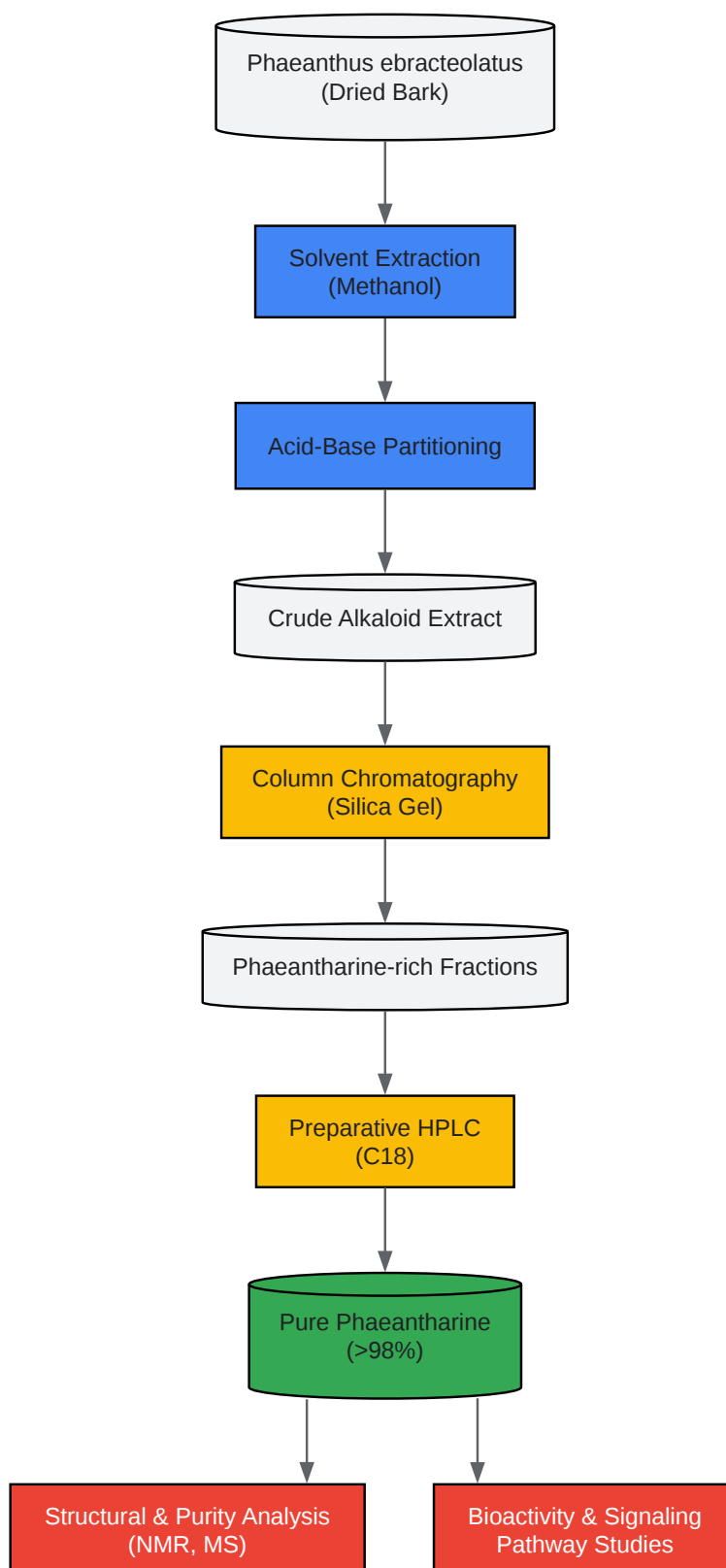

[Click to download full resolution via product page](#)

Caption: Workflow for **Phaeantharine** isolation and characterization.

## Conclusion

The protocols and data presented in these application notes provide a solid foundation for the successful extraction, purification, and preliminary characterization of **Phaeantharine**. While further research is required to elucidate the specific quantitative aspects of these processes for **Phaeantharine** and to definitively map its interactions with cellular signaling pathways, the methodologies outlined here, based on established procedures for similar compounds, offer a robust starting point for researchers in natural product chemistry and drug discovery.

- To cite this document: BenchChem. [Application Notes and Protocols for Phaeantharine Extraction and Purification]. BenchChem, [2026]. [Online PDF]. Available at: [\[https://www.benchchem.com/product/b1203911/docs#application-notes-and-protocols-for-phaeantharine-extraction-and-purification\]](https://www.benchchem.com/product/b1203911/docs#application-notes-and-protocols-for-phaeantharine-extraction-and-purification)

---

### Disclaimer & Data Validity:

The information provided in this document is for Research Use Only (RUO) and is strictly not intended for diagnostic or therapeutic procedures. While BenchChem strives to provide accurate protocols, we make no warranties, express or implied, regarding the fitness of this product for every specific experimental setup.

**Technical Support:** The protocols provided are for reference purposes. Unsure if this reagent suits your experiment?

**Need Industrial/Bulk Grade?** [Request Custom Synthesis Quote](#)

## BenchChem

Our mission is to be the trusted global source of essential and advanced chemicals, empowering scientists and researchers to drive progress in science and industry.

### Contact

Address: 3281 E Guasti Rd  
Ontario, CA 91761, United States  
Phone: (601) 213-4426  
Email: [info@benchchem.com](mailto:info@benchchem.com)

Contact our Ph.D. Support Team for a compatibility check