

An In-depth Technical Guide to Tetraamylammonium Chloride

Author: BenchChem Technical Support Team. **Date:** April 2026

Compound of Interest

Compound Name: *Tetraamylammonium chloride*

CAS No.: 4965-17-7

Cat. No.: B1203234

[Get Quote](#)

For Researchers, Scientists, and Drug Development Professionals

Abstract

Tetraamylammonium chloride (CAS Number: 4965-17-7), a quaternary ammonium salt, serves as a pivotal phase-transfer catalyst in modern organic synthesis. Its molecular structure, featuring a central nitrogen atom bonded to four pentyl groups and a chloride counter-ion, imparts lipophilic properties that are essential for its catalytic activity. This enables the transport of reactants across the interface of immiscible solvent systems, thereby accelerating reaction rates and enhancing product yields. This technical guide provides a comprehensive overview of the physicochemical properties, synthesis, and applications of **tetraamylammonium chloride**, with a particular focus on its role in facilitating organic reactions. Detailed experimental protocols and a mechanistic illustration of phase-transfer catalysis are also presented to support its practical application in research and development.

Physicochemical Properties

Tetraamylammonium chloride is a white crystalline solid that is stable under standard laboratory conditions.[1] It is incompatible with strong oxidizing agents.[1] The key

physicochemical properties are summarized in the table below for easy reference and comparison.

| Property | Value | Reference(s) |
|-------------------|-------------------------------------|--------------|
| CAS Number | 4965-17-7 | [2] |
| Molecular Formula | C ₂₀ H ₄₄ ClN | [2] |
| Molecular Weight | 334.0 g/mol | [2] |
| Appearance | White crystalline solid | [1] |
| Melting Point | ~195 °C | [1] |
| Boiling Point | Not available | [1][3] |
| Density | Not available | [1][3] |
| Solubility | Almost transparent in water | [1] |
| Vapor Density | 11.5 (vs air) | [1] |
| Stability | Stable under normal conditions | [1] |

Synthesis of Tetraamylammonium Chloride

The synthesis of tetraalkylammonium halides, such as **tetraamylammonium chloride**, is typically achieved through the quaternization of a tertiary amine with an alkyl halide. This reaction, a type of Menshutkin reaction, involves the nucleophilic attack of the nitrogen atom of the amine on the electrophilic carbon of the alkyl halide.

A general experimental protocol for the synthesis of a tetraalkylammonium salt is as follows. While this is a generalized procedure, it can be adapted for the specific synthesis of **tetraamylammonium chloride**.

Experimental Protocol: Synthesis of a Tetraalkylammonium Halide

Materials:

- Trialkylamine (e.g., Tripentylamine for the synthesis of **Tetraamylammonium chloride**)

- Alkyl halide (e.g., 1-chloropentane for the synthesis of **Tetraamylammonium chloride**)
- Anhydrous solvent (e.g., acetonitrile, acetone, or THF)
- Inert gas (e.g., nitrogen or argon)
- Equipment for reflux, stirring, and filtration
- Rotary evaporator
- Recrystallization solvents (e.g., diethyl ether, ethyl acetate/hexane)

Procedure:

- In a round-bottom flask equipped with a magnetic stirrer, a reflux condenser, and a nitrogen inlet, dissolve the trialkylamine in the chosen anhydrous solvent.
- Slowly add a stoichiometric equivalent of the alkyl halide to the stirred solution at room temperature.
- Heat the reaction mixture to reflux and maintain this temperature for several hours to overnight. The progress of the reaction can be monitored by thin-layer chromatography (TLC).
- After the reaction is complete, cool the mixture to room temperature. The product may precipitate out of the solution.
- If a precipitate has formed, collect the solid by vacuum filtration and wash it with a small amount of cold solvent.
- If no precipitate forms, remove the solvent under reduced pressure using a rotary evaporator.
- Purify the crude product by recrystallization from an appropriate solvent system to obtain the pure tetraalkylammonium halide.
- Dry the purified crystals under vacuum.

Applications in Organic Synthesis: Phase-Transfer Catalysis

Tetraamylammonium chloride's primary application is as a phase-transfer catalyst (PTC).[2] PTCs are invaluable in reactions where the reactants are in different, immiscible phases, such as a solid-liquid or a liquid-liquid system. The catalyst facilitates the transfer of a reactant from one phase to another, allowing the reaction to proceed. Quaternary ammonium salts with long alkyl chains, like **tetraamylammonium chloride**, are particularly effective due to their solubility in organic solvents.[4]

The mechanism of phase-transfer catalysis involves the quaternary ammonium cation (Q^+) forming an ion pair with the reactant anion (Y^-) from the aqueous or solid phase. This lipophilic ion pair $[Q^+Y^-]$ is soluble in the organic phase and can migrate into it. In the organic phase, the anion is less solvated and therefore more reactive, readily participating in the desired reaction with the organic substrate (RX) to form the product (RY) and a new anion (X^-). The catalyst cation then transports the new anion back to the aqueous or solid phase, completing the catalytic cycle.

Below is a diagram illustrating the general mechanism of phase-transfer catalysis in a liquid-liquid system.

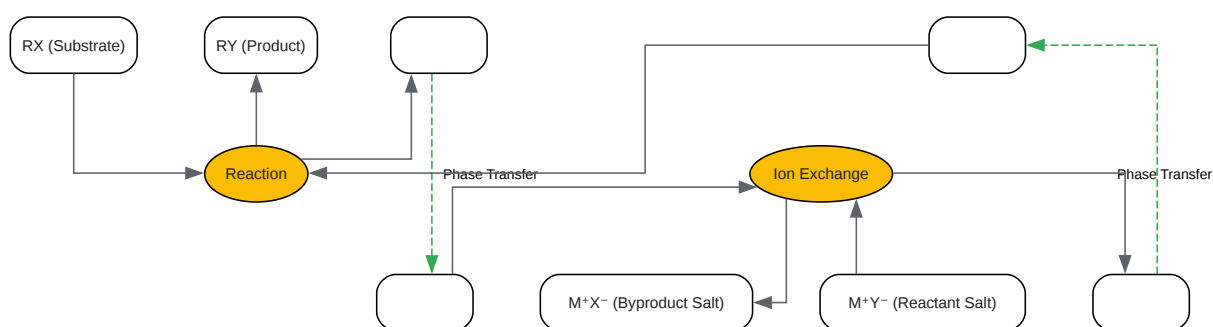

[Click to download full resolution via product page](#)

Mechanism of Phase-Transfer Catalysis

Experimental Protocols: Williamson Ether Synthesis

The Williamson ether synthesis is a classic example of a reaction that benefits from phase-transfer catalysis. It involves the reaction of an alkoxide with a primary alkyl halide. When the alkoxide is generated from a phenol, the resulting phenoxide is often soluble in an aqueous base, while the alkyl halide is soluble in an organic solvent. A phase-transfer catalyst like **tetraamylammonium chloride** can facilitate this reaction.

Experimental Protocol: Phase-Transfer Catalyzed Williamson Ether Synthesis

Materials:

- Phenol (e.g., 4-ethylphenol)
- Alkyl halide (e.g., methyl iodide)
- Aqueous sodium hydroxide (e.g., 25% w/v)
- **Tetraamylammonium chloride** (as the phase-transfer catalyst)
- Organic solvent (e.g., dichloromethane or toluene)
- Equipment for reflux, stirring, and extraction
- Drying agent (e.g., anhydrous sodium sulfate)
- Rotary evaporator
- Apparatus for purification (e.g., column chromatography)

Procedure:

- In a round-bottom flask equipped with a magnetic stirrer and a reflux condenser, dissolve the phenol in the organic solvent.
- Add the aqueous sodium hydroxide solution to the flask.

- Add a catalytic amount of **tetraamylammonium chloride** (typically 1-5 mol%) to the two-phase mixture.
- With vigorous stirring, add the alkyl halide to the reaction mixture.
- Heat the mixture to a gentle reflux and maintain for the required reaction time (this can be monitored by TLC).[5]
- After the reaction is complete, cool the mixture to room temperature.
- Transfer the mixture to a separatory funnel and separate the organic layer.
- Wash the organic layer with water and then with brine.
- Dry the organic layer over anhydrous sodium sulfate, filter, and concentrate the solvent under reduced pressure using a rotary evaporator.
- Purify the crude product by a suitable method, such as column chromatography, to yield the desired ether.[5]

Safety and Handling

Tetraamylammonium chloride is a hazardous substance and should be handled with appropriate safety precautions. It is harmful if swallowed, causes severe skin burns and eye damage, and may cause an allergic skin reaction and respiratory irritation. Always handle this chemical in a well-ventilated area or a fume hood, wearing appropriate personal protective equipment (PPE), including gloves, safety goggles, and a lab coat. In case of contact, immediately flush the affected area with plenty of water. If ingested or if irritation persists, seek immediate medical attention.

Conclusion

Tetraamylammonium chloride is a highly effective phase-transfer catalyst that plays a significant role in modern organic synthesis. Its ability to facilitate reactions between immiscible reactants makes it a valuable tool for researchers and chemists in academia and industry, including in the development of pharmaceuticals and agrochemicals. Understanding its properties, synthesis, and the mechanism of its catalytic action, as detailed in this guide, is

crucial for its successful application in the laboratory. Proper safety and handling procedures must be followed to ensure its safe use.

Need Custom Synthesis?

BenchChem offers custom synthesis for rare earth carbides and specific isotopic labeling.

Email: info@benchchem.com or [Request Quote Online](#).

References

- [1. Cas 4965-17-7, TETRA-N-PENTYLAMMONIUM CHLORIDE | lookchem \[lookchem.com\]](#)
- [2. 1-Pentanaminium, N,N,N-tripentyl-, chloride \(1:1\) | C20H44ClN | CID 78667 - PubChem \[pubchem.ncbi.nlm.nih.gov\]](#)
- [3. targetmol.com \[targetmol.com\]](#)
- [4. Phase transfer catalysis \(PTC\) - operachem \[operachem.com\]](#)
- [5. cactus.utahtech.edu \[cactus.utahtech.edu\]](#)
- To cite this document: BenchChem. [An In-depth Technical Guide to Tetraamylammonium Chloride]. BenchChem, [2026]. [Online PDF]. Available at: [\[https://www.benchchem.com/product/b1203234/docs#an-in-depth-technical-guide-to-tetraamylammonium-chloride\]](https://www.benchchem.com/product/b1203234/docs#an-in-depth-technical-guide-to-tetraamylammonium-chloride)

Disclaimer & Data Validity:

The information provided in this document is for Research Use Only (RUO) and is strictly not intended for diagnostic or therapeutic procedures. While BenchChem strives to provide accurate protocols, we make no warranties, express or implied, regarding the fitness of this product for every specific experimental setup.

Technical Support: The protocols provided are for reference purposes. Unsure if this reagent suits your experiment?

Need Industrial/Bulk Grade? [Request Custom Synthesis Quote](#)

BenchChem

Our mission is to be the trusted global source of essential and advanced chemicals, empowering scientists and researchers to drive progress in science and industry.

Contact

Address: 3281 E Guasti Rd

Ontario, CA 91761, United States

Phone: (601) 213-4426

Email: info@benchchem.com

[Contact our Ph.D. Support Team for a compatibility check](#)