

# The Complete Biosynthesis Pathway of Stearyl-CoA: An In-depth Technical Guide

**Author:** BenchChem Technical Support Team. **Date:** April 2026

## Compound of Interest

Compound Name: Stearyl-CoA

CAS No.: 362-66-3

Cat. No.: B1202530

[Get Quote](#)

For Researchers, Scientists, and Drug Development Professionals

This technical guide provides a comprehensive overview of the complete biosynthesis pathway of **Stearyl-CoA**, an essential 18-carbon saturated fatty acyl-CoA. The synthesis of **Stearyl-CoA** is a critical process in cellular metabolism, providing a key substrate for the formation of various lipids, including phospholipids, triglycerides, and cholesterol esters. Understanding this pathway is paramount for research in metabolic diseases, oncology, and the development of novel therapeutics targeting lipid metabolism.

## Overview of Stearyl-CoA Biosynthesis

The biosynthesis of **Stearyl-CoA** is a multi-step process that originates with the fundamental building block, Acetyl-CoA. The pathway can be broadly divided into two major stages:

- **De Novo Fatty Acid Synthesis:** The initial synthesis of the 16-carbon saturated fatty acyl-CoA, Palmitoyl-CoA, from Acetyl-CoA in the cytoplasm.
- **Microsomal Fatty Acid Elongation:** The subsequent elongation of Palmitoyl-CoA to the 18-carbon **Stearyl-CoA** in the endoplasmic reticulum.

## De Novo Synthesis of Palmitoyl-CoA

The de novo synthesis of fatty acids is a cyclical process catalyzed by a multi-enzyme complex known as Fatty Acid Synthase (FAS). The process begins with the carboxylation of Acetyl-CoA to form Malonyl-CoA, the committed step in fatty acid synthesis.

### Carboxylation of Acetyl-CoA

- Enzyme: Acetyl-CoA Carboxylase (ACC)
- Substrates: Acetyl-CoA, ATP, Bicarbonate ( $\text{HCO}_3^-$ )
- Product: Malonyl-CoA
- Description: This irreversible reaction is the primary regulatory point for de novo fatty acid synthesis. ACC is subject to allosteric regulation by citrate (activator) and long-chain fatty acyl-CoAs (inhibitor), as well as covalent modification via phosphorylation.

### Fatty Acid Synthase (FAS) Cycle

The FAS complex catalyzes a repeating four-step sequence, adding two carbons from Malonyl-CoA to the growing fatty acyl chain in each cycle. The cycle begins with the priming of FAS with one molecule of Acetyl-CoA.

- Condensation: Acetyl-CoA and Malonyl-CoA are transferred to the acyl carrier protein (ACP) domain of FAS. The initial condensation reaction combines the acetyl group with the malonyl group, releasing  $\text{CO}_2$ .
- Reduction: The resulting  $\beta$ -ketoacyl-ACP is reduced to a  $\beta$ -hydroxyacyl-ACP, utilizing NADPH as the reducing agent.
- Dehydration: A molecule of water is removed to form a trans- $\alpha,\beta$ -enoyl-ACP.
- Reduction: The double bond is reduced, again using NADPH, to form a saturated acyl-ACP.

This four-step cycle is repeated six more times, with Malonyl-CoA serving as the two-carbon donor in each cycle, ultimately yielding Palmitoyl-ACP. The final product, Palmitoyl-CoA, is released from the ACP by the action of a thioesterase.

## Microsomal Elongation of Palmitoyl-CoA to Stearyl-CoA

The conversion of Palmitoyl-CoA to **Stearyl-CoA** occurs in the endoplasmic reticulum through a microsomal fatty acid elongation system. This system is distinct from the cytosolic FAS and involves a series of membrane-bound enzymes. The overall process adds a two-carbon unit from Malonyl-CoA to Palmitoyl-CoA.[1]

This elongation process also consists of a four-step cycle:

- **Condensation:** This is the rate-limiting step, where Palmitoyl-CoA is condensed with Malonyl-CoA to form a  $\beta$ -ketoacyl-CoA. This reaction is catalyzed by a family of enzymes known as fatty acid elongases (Elovl).
- **Reduction:** The  $\beta$ -ketoacyl-CoA is then reduced to a 3-hydroxyacyl-CoA by a  $\beta$ -ketoacyl-CoA reductase, using NADPH as the electron donor.
- **Dehydration:** A 3-hydroxyacyl-CoA dehydratase catalyzes the removal of a water molecule to form a trans-2,3-enoyl-CoA.
- **Reduction:** Finally, a trans-2,3-enoyl-CoA reductase utilizes NADPH to reduce the double bond, yielding the elongated 18-carbon **Stearyl-CoA**.

## Key Enzymes in Palmitoyl-CoA Elongation

The specificity and rate of the elongation process are primarily determined by the fatty acid elongase (Elovl) enzymes. Several members of the Elovl family have been identified, with varying substrate specificities. For the elongation of saturated fatty acids like Palmitoyl-CoA, the following elongases are of particular importance:

- **Elovl1:** Exhibits activity towards a broad range of saturated and monounsaturated fatty acyl-CoAs, including Palmitoyl-CoA.[2]
- **Elovl3:** Also demonstrates activity with saturated and monounsaturated fatty acyl-CoAs.[3]
- **Elovl6:** Shows a preference for the elongation of C12-C16 saturated and monounsaturated fatty acyl-CoAs, making it a key enzyme in the conversion of Palmitoyl-CoA to **Stearyl-CoA**.

## Quantitative Data

The following table summarizes the available quantitative data for the kinetic parameters of the key enzymes involved in the elongation of Palmitoyl-CoA. It is important to note that obtaining precise kinetic data for membrane-bound enzymes like the elongases can be challenging, and values may vary depending on the experimental system and conditions.

Enzyme	Substrate	Km ( $\mu\text{M}$ )	Vmax (pmol/min/ $\mu\text{g}$ protein)	Source Organism/System
ELOVL6	Palmitoyl-CoA	1.22	0.79	Purified 3xFLAG-ELOVL6 reconstituted into proteoliposomes
ELOVL6	Malonyl-CoA	6.46	1.03	Purified 3xFLAG-ELOVL6 reconstituted into proteoliposomes

Note: Comprehensive kinetic data for ELOVL1 and ELOVL3 with Palmitoyl-CoA as a substrate is limited in the current literature.

## Experimental Protocols

### In Vitro Fatty Acid Elongation Assay for Stearyl-CoA Synthesis

This protocol describes a method to measure the in vitro conversion of Palmitoyl-CoA to **Stearyl-CoA** using microsomal fractions.

Materials:

- Microsomal protein fraction isolated from a relevant cell line or tissue (e.g., liver).
- [1-<sup>14</sup>C]Palmitoyl-CoA (or other radiolabeled Palmitoyl-CoA).

- Malonyl-CoA.
- NADPH.
- Reaction buffer (e.g., 100 mM potassium phosphate buffer, pH 7.4).
- Stopping solution (e.g., 10% KOH in methanol).
- Hexane.
- Scintillation cocktail and counter.
- Thin-layer chromatography (TLC) plates and developing solvent (e.g., petroleum ether:diethyl ether:acetic acid, 80:20:1, v/v/v).

#### Procedure:

- **Microsome Preparation:** Isolate microsomes from the desired source using standard differential centrifugation techniques. Determine the protein concentration of the microsomal fraction using a standard protein assay (e.g., Bradford assay).
- **Reaction Setup:** In a microcentrifuge tube, prepare the reaction mixture containing:
  - Microsomal protein (e.g., 50-100  $\mu\text{g}$ ).
  - Reaction buffer.
  - Malonyl-CoA (e.g., 50  $\mu\text{M}$ ).
  - NADPH (e.g., 200  $\mu\text{M}$ ).
- **Initiation:** Start the reaction by adding [1- $^{14}\text{C}$ ]Palmitoyl-CoA (e.g., 10  $\mu\text{M}$ , specific activity  $\sim 50$  dpm/pmol).
- **Incubation:** Incubate the reaction mixture at 37°C for a defined period (e.g., 10-30 minutes).
- **Termination:** Stop the reaction by adding the stopping solution.
- **Saponification:** Saponify the fatty acyl-CoAs by incubating at 70°C for 1 hour.

- Extraction: Acidify the reaction mixture with HCl and extract the fatty acids with hexane.
- Analysis:
  - Scintillation Counting: Evaporate the hexane and measure the radioactivity of the extracted fatty acids using a scintillation counter to determine the total amount of elongated product.
  - TLC Analysis: Alternatively, spot the hexane extract onto a TLC plate and develop the chromatogram. Visualize the separated fatty acids (e.g., using iodine vapor or a phosphorimager for radiolabeled compounds). Scrape the spots corresponding to Palmitic acid and Stearic acid and quantify the radioactivity in each to determine the conversion rate.

## Regulatory Pathways

The biosynthesis of **Stearyl-CoA** is tightly regulated at the transcriptional level, primarily by the sterol regulatory element-binding protein-1c (SREBP-1c) and the liver X receptor (LXR).

### SREBP-1c Activation and Signaling

SREBP-1c is a transcription factor that upregulates the expression of genes involved in fatty acid synthesis and elongation, including the Elovl genes.<sup>[4]</sup> SREBP-1c is synthesized as an inactive precursor bound to the endoplasmic reticulum membrane. Its activation involves a multi-step process:

- ER to Golgi Translocation: In response to cellular signals such as insulin, the SREBP-1c/SCAP complex is transported from the ER to the Golgi apparatus.
- Proteolytic Cleavage: In the Golgi, SREBP-1c undergoes two sequential proteolytic cleavages by Site-1 Protease (S1P) and Site-2 Protease (S2P).<sup>[5]</sup>
- Nuclear Translocation: The released N-terminal domain of SREBP-1c (nSREBP-1c) translocates to the nucleus.
- Gene Transcription: In the nucleus, nSREBP-1c binds to Sterol Regulatory Elements (SREs) in the promoter regions of its target genes, thereby activating their transcription.

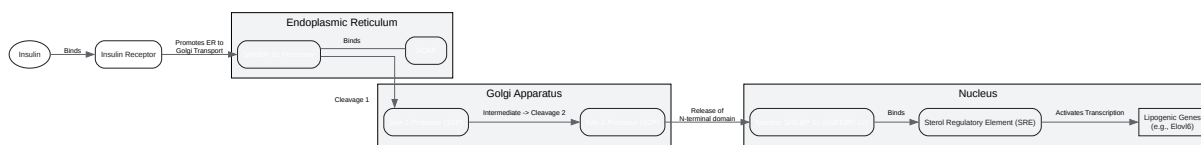

[Click to download full resolution via product page](#)

### SREBP-1c Activation Pathway

## LXR Regulation of Lipogenesis

Liver X receptors (LXRs) are nuclear receptors that play a crucial role in cholesterol and fatty acid metabolism. Upon activation by oxysterols (oxidized derivatives of cholesterol), LXRs form a heterodimer with the retinoid X receptor (RXR) and bind to LXR response elements (LXREs) in the promoter of target genes. One of the key target genes of LXR is SREBF1, the gene encoding SREBP-1c.[6] By inducing the expression of SREBP-1c, LXR indirectly promotes the entire lipogenic program, including the synthesis of **Stearyl-CoA**.

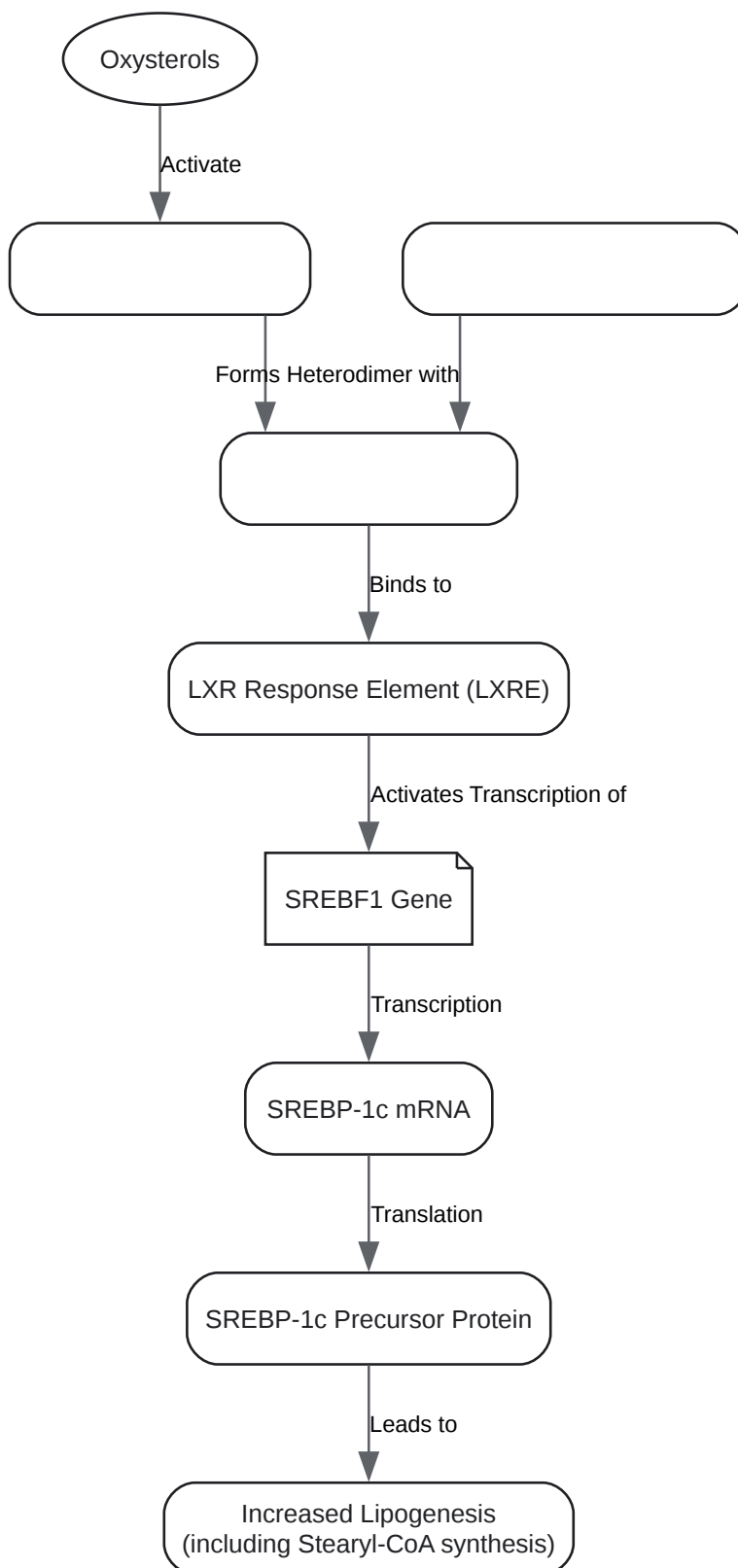

[Click to download full resolution via product page](#)

LXR Regulation of SREBP-1c and Lipogenesis



# Logical Workflow for Studying Stearyl-CoA Biosynthesis

The following diagram outlines a logical workflow for investigating the biosynthesis of **Stearyl-CoA**, from initial gene expression analysis to functional enzymatic assays.

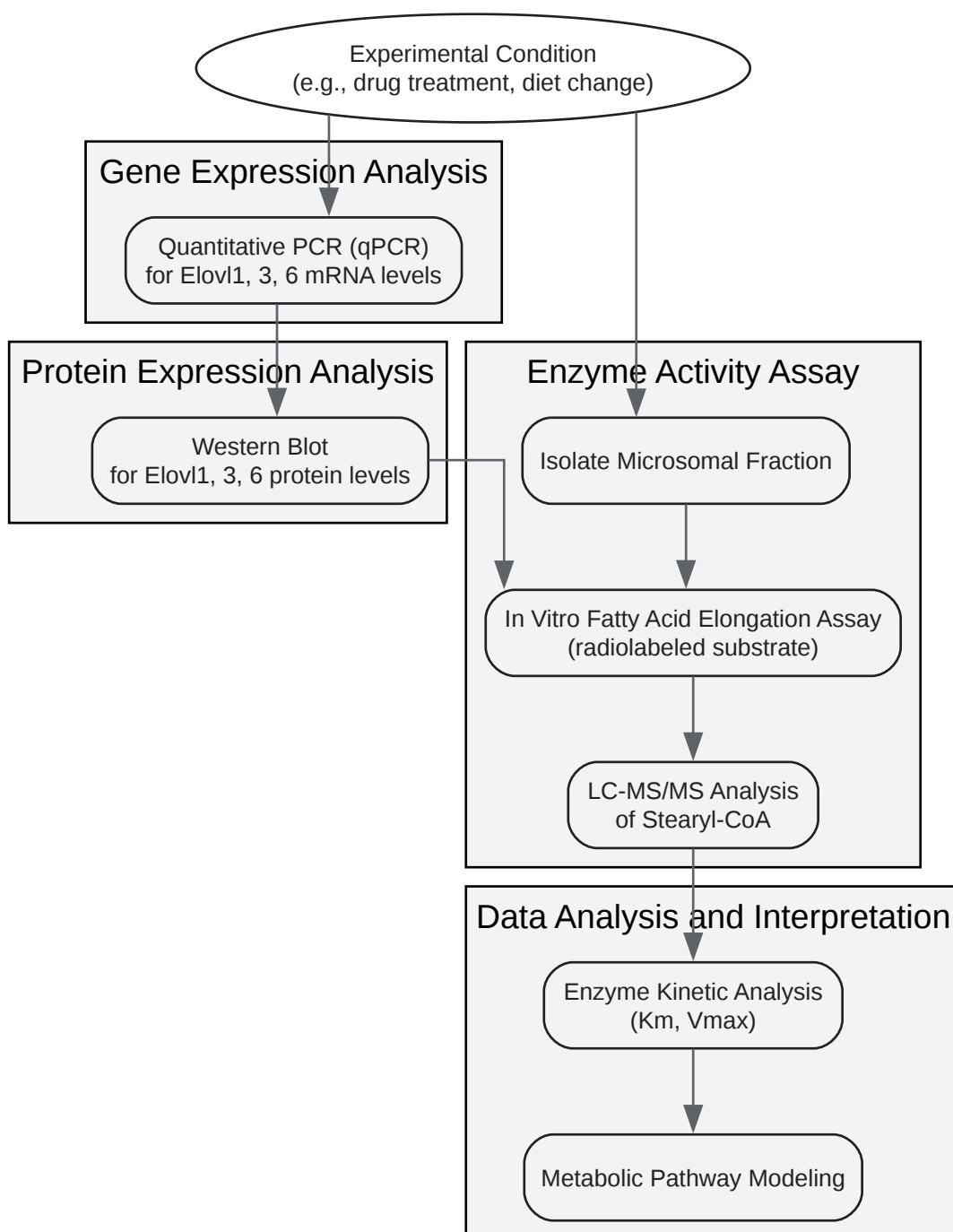

[Click to download full resolution via product page](#)

### Need Custom Synthesis?

BenchChem offers custom synthesis for rare earth carbides and specific isotopic labeling.

Email: [info@benchchem.com](mailto:info@benchchem.com) or [Request Quote Online](#).

## References

- [1. Mammalian Fatty Acid Elongases - PMC \[pmc.ncbi.nlm.nih.gov\]](#)
- [2. researchgate.net \[researchgate.net\]](#)
- [3. On the pivotal role of Elovl3/ELOVL3 in meibogenesis and ocular physiology of mice - PMC \[pmc.ncbi.nlm.nih.gov\]](#)
- [4. Sterol regulatory element-binding protein - Wikipedia \[en.wikipedia.org\]](#)
- [5. Sterol Regulatory Element-binding Protein \(SREBP\) Cleavage Regulates Golgi-to-Endoplasmic Reticulum Recycling of SREBP Cleavage-activating Protein \(SCAP\) - PMC \[pmc.ncbi.nlm.nih.gov\]](#)
- [6. Regulation of mouse sterol regulatory element-binding protein-1c gene \(SREBP-1c\) by oxysterol receptors, LXR \$\alpha\$  and LXR \$\beta\$  - PMC \[pmc.ncbi.nlm.nih.gov\]](#)
- To cite this document: BenchChem. [The Complete Biosynthesis Pathway of Stearyl-CoA: An In-depth Technical Guide]. BenchChem, [2026]. [Online PDF]. Available at: [\[https://www.benchchem.com/product/b1202530/docs#the-complete-biosynthesis-pathway-of-stearyl-coa-an-in-depth-technical-guide\]](https://www.benchchem.com/product/b1202530/docs#the-complete-biosynthesis-pathway-of-stearyl-coa-an-in-depth-technical-guide)

### Disclaimer & Data Validity:

The information provided in this document is for Research Use Only (RUO) and is strictly not intended for diagnostic or therapeutic procedures. While BenchChem strives to provide accurate protocols, we make no warranties, express or implied, regarding the fitness of this product for every specific experimental setup.

**Technical Support:** The protocols provided are for reference purposes. Unsure if this reagent suits your experiment?

**Need Industrial/Bulk Grade?** [Request Custom Synthesis Quote](#)

# BenchChem

Our mission is to be the trusted global source of essential and advanced chemicals, empowering scientists and researchers to drive progress in science and industry.

## Contact

Address: 3281 E Guasti Rd

Ontario, CA 91761, United States

Phone: (601) 213-4426

Email: [info@benchchem.com](mailto:info@benchchem.com)

[Contact our Ph.D. Support Team for a compatibility check](#)