

Modifying B-428 experimental protocol for better results

Author: BenchChem Technical Support Team. **Date:** April 2026

Compound of Interest

Compound Name: B-428
CAS No.: 154628-42-9
Cat. No.: B1201740

[Get Quote](#)

B-428 Experimental Protocol: Technical Support Center

This guide provides troubleshooting advice and answers to frequently asked questions for researchers using the **B-428** compound, a selective inhibitor of the Apoptosis-Signal Regulating Kinase 2 (ASRK2). The primary application of **B-428** is to study the ASRK2-p38 MAPK signaling pathway's role in cancer cell lines.

Frequently Asked Questions (FAQs) & Troubleshooting

Q1: Why am I observing inconsistent IC50 values for **B-428** in my cell viability assays?

A1: Inconsistent IC50 values are a common issue that can arise from several factors related to assay conditions and cell health.^[1] Key areas to investigate include cell seeding density, compound precipitation, and reagent variability.

- Cell Health and Density: Ensure your cells are healthy, in a logarithmic growth phase, and seeded at an optimal density.[2] Over-confluent or sparse cultures can lead to variable metabolic rates, affecting assay results. It is recommended to perform a cell density titration to find the linear range for your specific cell line.[3]
- Compound Solubility: **B-428** can precipitate in aqueous media at high concentrations. Visually inspect your dilution plates for any signs of precipitation.[4]
- Pipetting and Reagent Consistency: Inaccurate pipetting can introduce significant errors.[1] Ensure pipettes are calibrated and use fresh, consistent lots of media and assay reagents for all experiments.

Q2: My Western blot does not show a decrease in phosphorylated p38 (p-p38) levels after **B-428** treatment. What went wrong?

A2: The absence of a change in p-p38 levels is a frequent problem in phosphoprotein analysis, often stemming from sample handling or issues with the blotting protocol.[5][6]

- Rapid Dephosphorylation: Phosphorylation is a reversible process.[6] Once cells are lysed, phosphatases are released and can rapidly dephosphorylate your target protein. It is critical to work quickly, keep samples on ice at all times, and use lysis buffers supplemented with a fresh cocktail of phosphatase inhibitors.[7]
- Low Protein Abundance: Phosphorylated proteins are often present in low amounts.[8] You may need to load a higher total protein concentration onto your gel than you would for a non-phosphorylated target.
- Blocking Agent: Avoid using milk as a blocking agent. Milk contains casein, a phosphoprotein, which can cause high background signals and interfere with antibody binding.[6][9] Use Bovine Serum Albumin (BSA) instead.
- Antibody Specificity: Ensure your primary antibody is specific for the phosphorylated form of p38. Always run a control for total p38 to confirm that the overall protein levels are unchanged and to serve as a loading control.[8]

Q3: **B-428** appears to be precipitating in my cell culture media. How can I improve its solubility?

A3: Small molecule inhibitors can have limited solubility in aqueous solutions like cell culture media.

- Solvent Concentration: While **B-428** is soluble in DMSO, the final concentration of DMSO in the cell culture medium should be kept low (typically $\leq 0.5\%$) to avoid solvent-induced cytotoxicity.[\[10\]](#)
- Dilution Method: Prepare serial dilutions of **B-428** in DMSO first. Then, add the final DMSO stock solution directly to the media in the well while gently mixing. This "spike-in" method often works better than pre-diluting the compound in a large volume of media.[\[10\]](#)
- Serum Content: The presence of serum proteins, like albumin, can help stabilize small molecules and improve their apparent solubility.[\[4\]](#) If you are using serum-free media for your experiment, you may need to accept a lower maximum concentration of **B-428**.

Q4: What are the recommended positive and negative controls for experiments involving **B-428**?

A4: Proper controls are essential for interpreting your results correctly.

- Positive Control (Pathway Activation): To confirm the ASRK2-p38 pathway is active in your cell model, you can treat cells with a known activator like Anisomycin or UV radiation. This should lead to a detectable increase in p-p38 levels.
- Negative Control (Vehicle): This is a crucial control to ensure that the solvent used to dissolve **B-428** (e.g., DMSO) does not have an effect on its own. Cells treated with the vehicle control should be compared to untreated cells and cells treated with **B-428**.
- Specificity Control: To investigate off-target effects, consider using a structurally different inhibitor of the p38 pathway or a negative control compound that is structurally similar to **B-428** but known to be inactive.[\[11\]](#)

Data Presentation

Table 1: Recommended **B-428** Concentration Ranges for Common Cell Lines

Cell Line	Cancer Type	Recommended Seeding Density (cells/well in 96-well plate)	Typical IC50 Range (72h)	Notes
A549	Lung Carcinoma	5,000 - 8,000	5 - 15 μ M	Ensure cells are well-adhered before treatment.
HeLa	Cervical Cancer	4,000 - 7,000	10 - 25 μ M	May require longer treatment times to see maximal effect.
MCF-7	Breast Cancer	8,000 - 12,000	2 - 10 μ M	Highly sensitive to p38 pathway inhibition. [12]
HUVEC	Non-cancerous	3,000 - 5,000	> 50 μ M	Used as a control for off-target cytotoxicity.

Table 2: Troubleshooting Guide for Western Blot Analysis of p-p38

Observation	Potential Cause	Recommended Solution
No signal for p-p38	1. Inefficient phosphorylation in cells. 2. Rapid dephosphorylation during sample prep.[7] 3. Insufficient protein loaded.[8]	1. Stimulate cells with a positive control (e.g., Anisomycin) to confirm pathway activity. 2. Use fresh phosphatase inhibitors in ice-cold lysis buffer. 3. Load 30-50 µg of total protein per lane.
High Background	1. Blocking with milk.[9] 2. Antibody concentration too high. 3. Insufficient washing.	1. Use 3-5% BSA in TBST for blocking. 2. Titrate primary and secondary antibody concentrations. 3. Increase the number and duration of TBST washes.
Bands for p-p38 in all lanes (including negative control)	1. Basal level of p38 activation is high. 2. Antibody is not specific and detects total p38. [8]	1. Serum-starve cells for 4-12 hours before treatment to reduce basal signaling. 2. Verify antibody specificity using manufacturer's data sheet. Run a lane with a known negative cell lysate if possible.
Signal for p-p38 is weak	1. Low abundance of target.[5] 2. Suboptimal antibody incubation. 3. Inefficient transfer to membrane.	1. Use a more sensitive chemiluminescent substrate.[8] 2. Incubate primary antibody overnight at 4°C. 3. Verify transfer efficiency with Ponceau S staining.

Experimental Protocols

Protocol 1: Cell Viability (MTT) Assay for B-428 Efficacy

This protocol outlines the measurement of cell viability by assessing the metabolic activity of cells, which reduces the yellow tetrazolium salt MTT to purple formazan crystals.[13][14]

- Cell Seeding: Seed cells into a 96-well plate at a pre-determined optimal density (see Table 1) in 100 μ L of complete culture medium. Incubate for 24 hours at 37°C, 5% CO₂ to allow for cell attachment.[3]
- Compound Preparation: Prepare a 2X serial dilution of **B-428** in culture medium from a DMSO stock. Ensure the final DMSO concentration in the well does not exceed 0.5%.
- Cell Treatment: Remove the old medium and add 100 μ L of the **B-428** dilutions to the appropriate wells. Include "vehicle-only" and "no-treatment" controls.
- Incubation: Incubate the plate for the desired treatment period (e.g., 48 or 72 hours).
- MTT Addition: Add 20 μ L of 5 mg/mL MTT solution to each well and incubate for 3-4 hours at 37°C, until purple formazan crystals are visible.
- Solubilization: Carefully remove the medium and add 150 μ L of DMSO to each well to dissolve the formazan crystals. Place the plate on an orbital shaker for 15 minutes, protected from light.[3]
- Absorbance Reading: Measure the absorbance at 570 nm using a microplate reader.

Protocol 2: Western Blot Analysis of Phosphorylated p38 (p-p38)

This method is used to detect the levels of p38 protein phosphorylated at Thr180/Tyr182, a key indicator of **B-428** target engagement.

- Cell Treatment & Lysis:
 - Seed cells in a 6-well plate and grow to 70-80% confluency.
 - Treat cells with **B-428** at desired concentrations for the specified time. Include positive (Anisomycin) and negative (vehicle) controls.
 - Aspirate medium, wash cells once with ice-cold PBS.

- Lyse the cells by adding 100-150 μ L of ice-cold RIPA buffer supplemented with a fresh protease and phosphatase inhibitor cocktail.[7]
- Scrape the cells and transfer the lysate to a pre-chilled microcentrifuge tube. Incubate on ice for 30 minutes.
- Centrifuge at 14,000 x g for 15 minutes at 4°C. Collect the supernatant.
- Protein Quantification: Determine the protein concentration of each lysate using a BCA assay.
- Sample Preparation & Electrophoresis:
 - Normalize all samples to the same protein concentration with lysis buffer. Add Laemmli sample buffer and boil at 95°C for 5 minutes.
 - Load 30-50 μ g of protein per lane onto an SDS-PAGE gel.
- Membrane Transfer: Transfer the separated proteins from the gel to a PVDF membrane.
- Blocking & Antibody Incubation:
 - Block the membrane with 5% BSA in Tris-Buffered Saline with 0.1% Tween-20 (TBST) for 1 hour at room temperature.[9]
 - Incubate the membrane with a primary antibody specific for p-p38 (Thr180/Tyr182) overnight at 4°C, with gentle agitation.
 - Wash the membrane three times for 10 minutes each with TBST.
 - Incubate with an HRP-conjugated secondary antibody for 1 hour at room temperature.
- Detection: Wash the membrane three times with TBST. Apply an enhanced chemiluminescence (ECL) substrate and visualize the bands using a digital imager.
- Stripping and Reprobing (Optional): The membrane can be stripped and re-probed with an antibody for total p38 to serve as a loading control.[6]

Visualizations

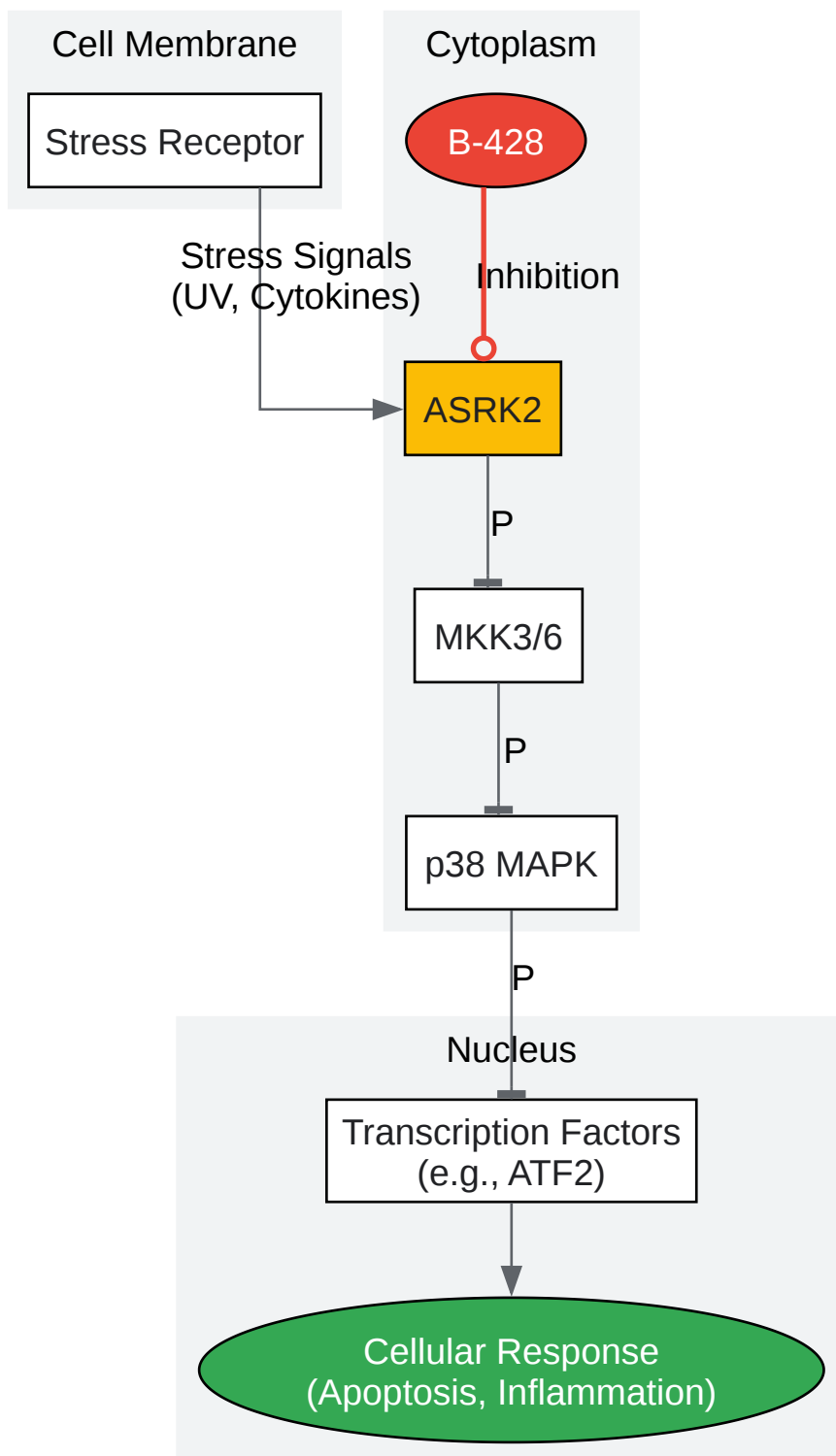

[Click to download full resolution via product page](#)

Caption: **B-428** inhibits ASRK2, blocking the downstream p38 MAPK signaling pathway.

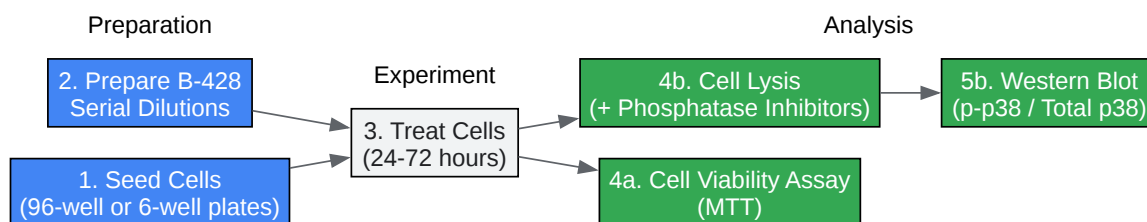

[Click to download full resolution via product page](#)

Caption: Experimental workflow for assessing **B-428** efficacy in cell culture.

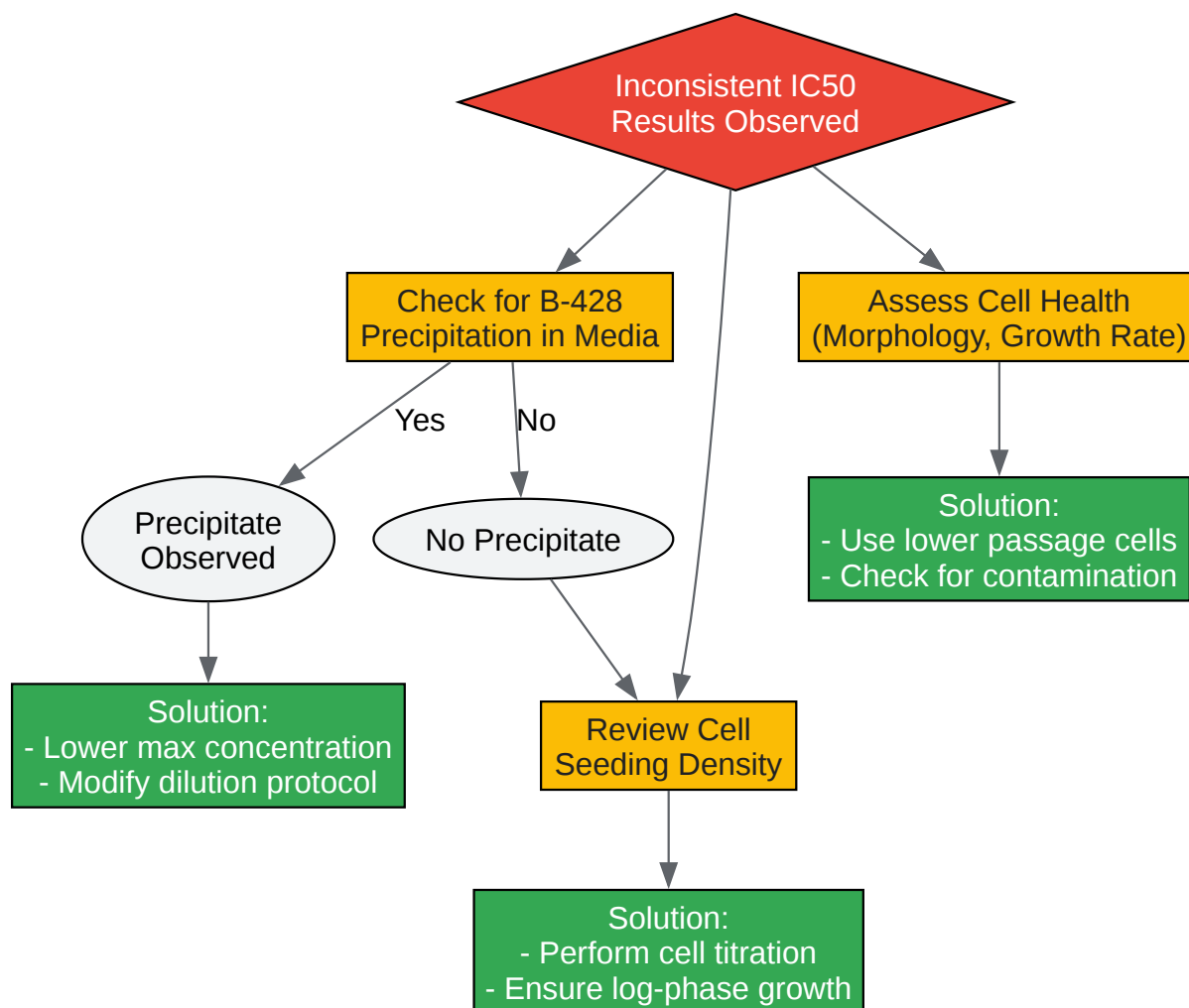

[Click to download full resolution via product page](#)

Caption: Troubleshooting logic for inconsistent IC50 values in viability assays.

Need Custom Synthesis?

BenchChem offers custom synthesis for rare earth carbides and specific isotopic labeling.

Email: info@benchchem.com or [Request Quote Online](#).

References

- [1. biocompare.com \[biocompare.com\]](#)
- [2. researchgate.net \[researchgate.net\]](#)
- [3. benchchem.com \[benchchem.com\]](#)
- [4. researchgate.net \[researchgate.net\]](#)
- [5. Protein Phosphorylation in Western Blotting: Key Challenges & Solutions - Creative Proteomics \[creative-proteomics.com\]](#)
- [6. Why Your Phosphorylated Protein Western Blot Isn't Working \(And How to Fix It\) \[absin.net\]](#)
- [7. Western Blot for Phosphorylated Proteins - Tips & Troubleshooting | Bio-Techne \[bio-techne.com\]](#)
- [8. Tips for detecting phosphoproteins by western blot | Proteintech Group \[ptglab.com\]](#)
- [9. Western blot for phosphorylated proteins | Abcam \[abcam.com\]](#)
- [10. researchgate.net \[researchgate.net\]](#)
- [11. benchchem.com \[benchchem.com\]](#)
- [12. Maples Scientific Publisher | Open Access Journals | Peer-reviewed Journals | MaplesPub \[maplespub.com\]](#)
- [13. Cell Viability Assays - Assay Guidance Manual - NCBI Bookshelf \[ncbi.nlm.nih.gov\]](#)
- [14. susupport.com \[susupport.com\]](#)
- To cite this document: BenchChem. [Modifying B-428 experimental protocol for better results]. BenchChem, [2026]. [Online PDF]. Available at: [\[https://www.benchchem.com/product/b1201740/docs#modifying-b-428-experimental-protocol-for-better-results\]](https://www.benchchem.com/product/b1201740/docs#modifying-b-428-experimental-protocol-for-better-results)

Disclaimer & Data Validity:

The information provided in this document is for Research Use Only (RUO) and is strictly not intended for diagnostic or therapeutic procedures. While BenchChem strives to provide accurate protocols, we make no warranties, express or implied, regarding the fitness of this product for every specific experimental setup.

Technical Support: The protocols provided are for reference purposes. Unsure if this reagent suits your experiment?

Need Industrial/Bulk Grade? [Request Custom Synthesis Quote](#)

BenchChem

Our mission is to be the trusted global source of essential and advanced chemicals, empowering scientists and researchers to drive progress in science and industry.

Contact

Address: 3281 E Guasti Rd
Ontario, CA 91761, United States
Phone: (601) 213-4426
Email: info@benchchem.com

[Contact our Ph.D. Support Team for a compatibility check](#)