

Application Note: Site-Selective Functionalization of 4-(Dimethylamino)-6-methyl-2-pyridone

Author: BenchChem Technical Support Team. **Date:** April 2026

Compound of Interest

Compound Name:	2(1H)-Pyridinone, 4-(dimethylamino)-6-methyl-
CAS No.:	137440-96-1
Cat. No.:	B12006273

[Get Quote](#)

Introduction & Mechanistic Analysis[1][2][3][4][5][6][7]

The target molecule, 4-(dimethylamino)-6-methyl-2-pyridone (1), contains three distinct sites of reactivity:

- The Lactam Core (N1-C2=O): Exists in tautomeric equilibrium, predominantly as the 2-pyridone. The N1-H is acidic ().
- The Electron-Rich Ring (C3/C5): The 4-NMe₂ group strongly activates the ring toward electrophilic aromatic substitution (EAS), particularly at C3 and C5.
- The C6-Methyl Group: This is the target. While "benzylic" in nature (adjacent to the

-system), its acidity is attenuated by the electron-donating capacity of the 4-NMe₂ group.

The Central Challenge: Standard reagents often target the highly nucleophilic C3 position (ortho-lithiation or electrophilic halogenation) rather than the C6-methyl group. Successful functionalization requires strategies that suppress ring reactivity or exploit specific radical/oxidative mechanisms.

Strategic Workflows

We define three primary routes for functionalization. The choice depends on the desired downstream intermediate (Aldehyde, Bromide, or Nucleophile).

Workflow Visualization

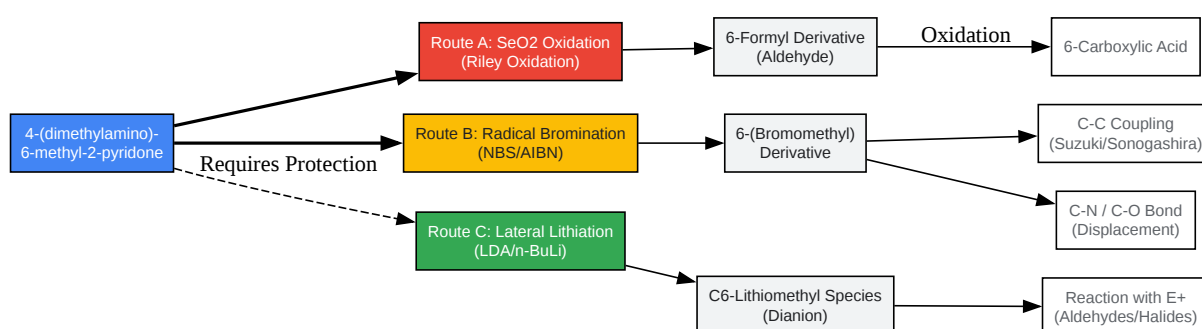

[Click to download full resolution via product page](#)

Caption: Divergent synthetic pathways for C6-methyl functionalization. Solid lines indicate high-probability routes; dashed lines indicate routes requiring specific protecting group strategies.

Detailed Protocols

Protocol A: Selenium Dioxide Oxidation (The "Riley" Route)

Target: 6-Formyl-4-(dimethylamino)-2-pyridone (Aldehyde) Mechanism: Ene-reaction followed by dehydration. The most robust method for this scaffold as it avoids competition with ring

electrophiles.

Reagents:

- Selenium Dioxide (SeO₂)[1][2][3][4]
- 1,4-Dioxane (Solvent)
- Optional: tert-Butyl hydroperoxide (TBHP) as a co-oxidant (allows catalytic SeO₂).

Step-by-Step Procedure:

- Setup: In a round-bottom flask equipped with a reflux condenser, dissolve 1 (1.0 equiv) in 1,4-dioxane (0.2 M concentration).
- Addition: Add finely powdered SeO₂ (1.2 - 1.5 equiv).
 - Note: For the catalytic variant, use 0.5 equiv SeO₂ and 2.0 equiv TBHP (70% aq).
- Reaction: Heat the mixture to reflux (100–105 °C) for 4–12 hours. Monitor by TLC/LCMS. The product (aldehyde) is often more polar than the starting material.
 - Observation: The precipitation of black selenium metal indicates reaction progress.
- Workup: Filter the hot solution through a pad of Celite to remove selenium metal. Wash the pad with hot dioxane or EtOAc.
- Purification: Concentrate the filtrate. The aldehyde often precipitates upon cooling or addition of diethyl ether. If not, purify via flash chromatography (DCM/MeOH gradient).

Data & Expectations:

Parameter	Expectation
Typical Yield	50–75%
Major Byproduct	6-Carboxylic acid (over-oxidation)

| Key NMR Signal | Aldehyde proton (-CHO) at δ 9.5–10.0 ppm (singlet) |

Protocol B: Radical Bromination (The "Halogenation" Route)

Target: 6-(Bromomethyl)-4-(dimethylamino)-2-pyridone Challenge: The electron-rich ring is prone to electrophilic bromination at C3. Solution: Protonation of the system (using HBr or acid scavengers) or strict radical conditions to favor the benzylic mechanism.

Reagents:

- N-Bromosuccinimide (NBS) (recrystallized)
- AIBN or Benzoyl Peroxide (Radical Initiator)
- Chlorobenzene or
-Trifluorotoluene (Solvents with high boiling points and low polarity).

Step-by-Step Procedure:

- Preparation: Dry the starting material 1 thoroughly.
- Solvation: Suspend 1 in Chlorobenzene (0.1 M).
- Reagent Addition: Add NBS (1.05 equiv) and AIBN (0.1 equiv).
- Deactivation (Critical): If ring bromination is observed in pilot runs, add 1.0 equiv of acetic acid or use the HBr salt of the pyridone. This protonates the 4-NMe₂ and the lactam, deactivating the ring toward electrophilic attack while leaving the methyl group accessible for radical abstraction.
- Initiation: Heat to 80–90 °C. An incandescent light source (sunlamp) can accelerate initiation.
- Monitoring: Stop the reaction immediately upon consumption of starting material to prevent di-bromination.
- Workup: Cool to 0 °C. Filter off the succinimide byproduct. Concentrate the filtrate.

- **Stability Note:** The bromomethyl product is reactive. Use immediately for alkylation (e.g., with amines or thiols) or store at -20 °C.

Protocol C: Lateral Lithiation (The "Nucleophilic" Route)

Target: C6-Alkylated derivatives. Constraint: Direct lithiation of 1 is difficult due to the acidic NH and competition from C3-lithiation. Requirement: N-Protection is mandatory for high yields.

Recommended Protecting Group: SEM (2-(Trimethylsilyl)ethoxymethyl) or Bn (Benzyl).

Step-by-Step Procedure:

- **Protection:** React 1 with NaH (1.1 equiv) in DMF, followed by SEM-Cl. Isolate the N-SEM protected intermediate.
- **Lithiation:** Dissolve N-SEM-1 in anhydrous THF (0.1 M) under Argon. Cool to -78 °C.^{[5][6]}
- **Deprotonation:** Add LDA (1.1 equiv) dropwise.
 - **Selectivity Note:** In 4-methoxy-2-pyridones, lithiation occurs at C3 (ortho). However, steric bulk at N (SEM) and the kinetic acidity of the methyl group may allow lateral lithiation.
 - **Alternative:** If C3 lithiation dominates, use LiTMP (more steric bulk) or allow the anion to warm to -20 °C to equilibrate to the thermodynamic benzylic anion (C6-CH₂Li).
- **Quench:** Add the electrophile (e.g., MeI, Benzaldehyde) at -78 °C.
- **Workup:** Quench with saturated NH₄Cl. Extract with EtOAc.

Troubleshooting & Optimization Table

Observation	Root Cause	Corrective Action
Reaction stalls (SeO ₂)	4-NMe ₂ deactivates methyl acidity.	Switch to SeO ₂ /TBHP protocol; increase temp to 120°C (sealed tube).
Ring Bromination (NBS)	Electrophilic attack on electron-rich ring.	Add 1.0 eq AcOH or TFA to reaction mixture to deactivate ring.
C3-Alkylation (Lithiation)	Kinetic deprotonation at ring C3.	Use "Directed Metalation Group" logic: Ensure N-protecting group is bulky. Allow anion equilibration (-40°C) before quench.
Low Solubility	Pyridone H-bonding network.	Use N-protected starting material or switch solvent to TFE (Trifluoroethanol) for non-lithium reactions.

References

- SeO₂ Oxidation (Riley Oxidation)
 - Detailed mechanistic insight into the oxidation of active methyl groups on N-heterocycles.
 - Reference: Sharpless, K. B., et al. "Selenium Dioxide Oxidation." [1] *Aldrichimica Acta*, 1979, 12, 63.[1]
 - Context: Validates the use of SeO₂/TBHP for methyl-pyridines.
- Lateral Lithiation of Pyridones
 - Discusses the competition between Ring (C3) and Lateral (Methyl)
 - Reference: Patel, P., & Joule, J. A. "Lithiation of Pyridones." *J. Chem. Soc., Chem. Commun.*, 1985, 1021.

- Context: Establishes that N-methyl-2-pyridone lithiates at N-Me, while 4-substituted analogs favor C3 without careful control.
- Functionalization of 4-Methoxy-2-pyridone (Analogous System): Demonstrates C3-lithiation preference in electron-rich pyridones. Reference: J. Chem. Soc., Perkin Trans. 1, 1980, various pages. (General consensus on 4-alkoxy direction).
- Radical Bromination of Electron-Rich Methyl Aromatics: Strategies for suppressing ring bromination using acid scavengers or protonation. Reference: Mitchell, R. H., et al. "N-Bromosuccinimide-Dimethylformamide: A Mild, Selective Nuclear Brominating Agent." J. Org. Chem., 1979, 44, 4733. (Contrast with radical conditions).

Need Custom Synthesis?

BenchChem offers custom synthesis for rare earth carbides and specific isotopic labeling.

Email: info@benchchem.com or [Request Quote Online](#).

Sources

- [1. pdfs.semanticscholar.org](https://pdfs.semanticscholar.org) [pdfs.semanticscholar.org]
- [2. archive.nptel.ac.in](https://archive.nptel.ac.in) [archive.nptel.ac.in]
- [3. dspacep01.emporia.edu](https://dspacep01.emporia.edu) [dspacep01.emporia.edu]
- [4. adichemistry.com](https://adichemistry.com) [adichemistry.com]
- 5. Lithiation of pyridones - Journal of the Chemical Society, Chemical Communications (RSC Publishing) [pubs.rsc.org]
- 6. Lithiation of 4-methoxy-2-pyridones. Synthetic entry to tenellin and funiculosin, and related natural 3,5-disubstituted 4-oxy-2-pyridones - Journal of the Chemical Society, Perkin Transactions 1 (RSC Publishing) [pubs.rsc.org]
- To cite this document: BenchChem. [Application Note: Site-Selective Functionalization of 4-(Dimethylamino)-6-methyl-2-pyridone]. BenchChem, [2026]. [Online PDF]. Available at: [<https://www.benchchem.com/product/b12006273/docs#application-note-site-selective-functionalization-of-4-dimethylamino-6-methyl-2-pyridone>]

Disclaimer & Data Validity:

The information provided in this document is for Research Use Only (RUO) and is strictly not intended for diagnostic or therapeutic procedures. While BenchChem strives to provide accurate protocols, we make no warranties, express or implied, regarding the fitness of this product for every specific experimental setup.

Technical Support: The protocols provided are for reference purposes. Unsure if this reagent suits your experiment?

Need Industrial/Bulk Grade? [Request Custom Synthesis Quote](#)

BenchChem

Our mission is to be the trusted global source of essential and advanced chemicals, empowering scientists and researchers to drive progress in science and industry.

Contact

Address: 3281 E Guasti Rd
Ontario, CA 91761, United States
Phone: (601) 213-4426
Email: info@benchchem.com

[Contact our Ph.D. Support Team for a compatibility check](#)