

Comparative Analysis: Analytical Modalities for Carbohydrate Validation

Author: BenchChem Technical Support Team. **Date:** April 2026

Compound of Interest

Compound Name: *2-N-Carbobenzyloxy-2-deoxy-D-glucosamine*

Cat. No.: *B12003371*

[Get Quote](#)

When validating a complex stereocenter-rich molecule like N-Cbz-D-glucosamine, relying on a single analytical technique often leads to structural ambiguity. The table below summarizes the performance of standard analytical modalities.

Analytical Modality	Stereochemical Resolution	Anomeric Ratio Quantification	Linkage/Connectivity Proof	Sample State	Structural Ambiguity
1D NMR (1H, 13C)	Low (Severe peak overlap)	Moderate (H1 integration)	Low (Cannot prove Cbz linkage)	Solution	High
Mass Spectrometry	Very Low (Stereoisomers share m/z)	None	Moderate (Via fragmentation)	Gas phase	High
X-ray Crystallography	Absolute	None (Captures static single state)	Absolute	Solid (Crystal)	Low (Lacks solution dynamics)
2D NMR Suite	High (NOESY/ROESY)	High (Resolved 2D integrations)	High (HMBC)	Solution	None

The Causality of Choice: Mass spectrometry can confirm the molecular weight of N-Cbz-D-glucosamine but fails to differentiate between its stereoisomers (e.g., mannosamine vs. glucosamine derivatives). X-ray crystallography provides absolute configuration but forces the molecule into a single static lattice, blinding us to the crucial α/β anomeric equilibrium present in physiological solutions. 2D NMR is the only modality that offers a holistic, solution-state validation of both connectivity and dynamic stereochemistry.

The 2D NMR Validation Protocol: A Self-Validating System

To ensure scientific integrity, the following protocol is designed as a self-validating system. The output of each spectroscopic experiment directly resolves the ambiguities of the previous step.

Step 1: Sample Preparation and Solvent Selection

- Action: Dissolve 15–20 mg of high-purity 2-N-Cbz-2-deoxy-D-glucosamine in 600 μL of deuterated dimethyl sulfoxide (DMSO-

).

).
- Causality: Standard practice often dictates using

for water-soluble carbohydrates. However, in

, the hydroxyl (-OH) and amide (-NH) protons undergo rapid chemical exchange with the solvent, rendering them invisible [3](#). By utilizing DMSO-

, this exchange is drastically slowed. The newly visible -OH and -NH resonances serve as highly resolved, unambiguous starting points for assembling the NMR "jigsaw puzzle," allowing us to trace connectivity from the outside of the ring inward.

Step 2: 1D Baseline & 1H-1H COSY (Correlation Spectroscopy)

- Action: Acquire a standard 1H spectrum followed by a 2D COSY experiment.
- Causality: Because the bulk of the pyranose ring protons (H2 through H6) cluster tightly between 3.5 and 4.0 ppm, 1D spectral overlap is inevitable. COSY establishes the scalar (through-bond) spin-spin coupling network. By identifying the well-resolved anomeric proton (H1, typically ~5.0–5.2 ppm), we can sequentially "walk" down the carbon backbone: H1 \rightarrow H2 \rightarrow H3 \rightarrow H4 \rightarrow H5 \rightarrow H6. This validates the contiguous nature of the glucosamine ring.

Step 3: 1H-13C HSQC (Heteronuclear Single Quantum Coherence)

- Action: Acquire a multiplicity-edited HSQC spectrum.
- Causality: Even with COSY, proton-proton overlap can cause assignment dead-ends. HSQC solves this by dispersing the crowded proton signals into the much wider ^{13}C chemical shift dimension (60–100 ppm for carbohydrates). It maps each proton to its directly attached carbon. Multiplicity editing provides an internal validation check by phase-inverting

groups, instantly differentiating the C6 position from the C1-C5 methine groups.

Step 4: ¹H-¹³C HMBC (Heteronuclear Multiple Bond Correlation)

- Action: Acquire an HMBC spectrum optimized for long-range couplings ($J_{\text{CH}} = 8 \text{ Hz}$).
- Causality: COSY and HSQC cannot prove connections across heteroatoms (like nitrogen or oxygen) or quaternary carbons. HMBC detects correlations across 2 to 3 bonds. For N-Cbz-D-glucosamine, HMBC is the definitive proof of the protecting group's location. A cross-peak between the H2 proton of the sugar ring and the carbamate carbonyl carbon of the Cbz group confirms the precise site of functionalization.

Step 5: 2D NOESY / ROESY (Nuclear Overhauser Effect Spectroscopy)

- Action: Acquire a NOESY spectrum with a mixing time of 300–500 ms.
- Causality: N-Cbz-D-glucosamine exists as an interconverting mixture of α and β anomers. NOESY detects through-space dipole-dipole interactions ($< 5 \text{ \AA}$). The β -anomer will exhibit a strong NOE cross-peak between the axial H1 and the axial H3/H5 protons. Conversely, the α -anomer (with an equatorial H1) will lack this specific interaction [2](#). This provides absolute confirmation of the stereochemical configurations and validates the anomeric ratios observed in the initial 1D spectrum.

Structural Validation Logical Workflow

The following diagram illustrates the self-validating logical progression of the 2D NMR suite described above.

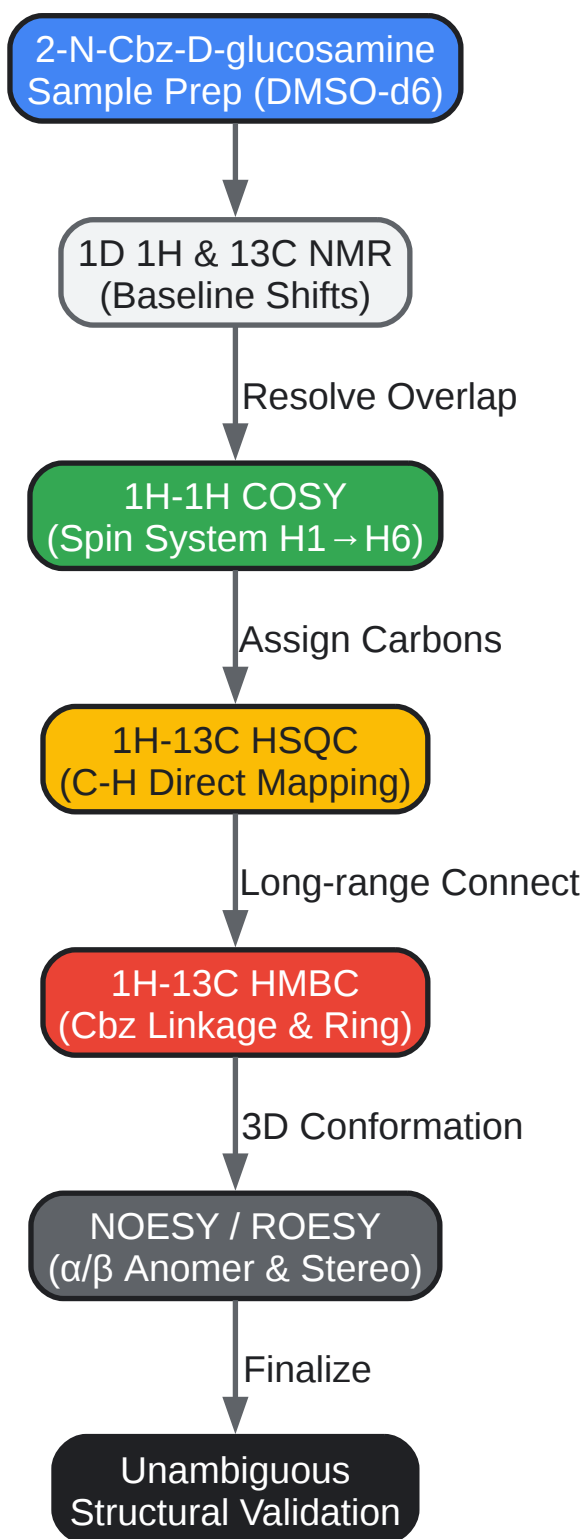

[Click to download full resolution via product page](#)

Fig 1: Logical workflow for the 2D NMR structural elucidation of 2-N-Cbz-2-deoxy-D-glucosamine.

References

- Source: National Institutes of Health (NIH)
- Source: University of Modena and Reggio Emilia (UNIMO)
- Source: National Institutes of Health (NIH)

Need Custom Synthesis?

BenchChem offers custom synthesis for rare earth carbides and specific isotopic labeling.

Email: info@benchchem.com or [Request Quote Online](#).

Sources

- [1. Structure-Based Approach to the Identification of a Novel Group of Selective Glucosamine Analogue Inhibitors of Trypanosoma cruzi Glucokinase - PMC \[pmc.ncbi.nlm.nih.gov\]](#)
- [2. cigs.unimo.it \[cigs.unimo.it\]](#)
- [3. A Solution NMR Approach To Determine the Chemical Structures of Carbohydrates Using the Hydroxyl Groups as Starting Points - PMC \[pmc.ncbi.nlm.nih.gov\]](#)
- To cite this document: BenchChem. [Comparative Analysis: Analytical Modalities for Carbohydrate Validation]. BenchChem, [2026]. [Online PDF]. Available at: [\[https://www.benchchem.com/product/b12003371/docs#comparative-analysis-analytical-modalities-for-carbohydrate-validation\]](https://www.benchchem.com/product/b12003371/docs#comparative-analysis-analytical-modalities-for-carbohydrate-validation)

Disclaimer & Data Validity:

The information provided in this document is for Research Use Only (RUO) and is strictly not intended for diagnostic or therapeutic procedures. While BenchChem strives to provide accurate protocols, we make no warranties, express or implied, regarding the fitness of this product for every specific experimental setup.

Technical Support: The protocols provided are for reference purposes. Unsure if this reagent suits your experiment?

Need Industrial/Bulk Grade? [Request Custom Synthesis Quote](#)

BenchChem

Our mission is to be the trusted global source of essential and advanced chemicals, empowering scientists and researchers to drive progress in science and industry.

Contact

Address: 3281 E Guasti Rd
Ontario, CA 91761, United States
Phone: (601) 213-4426
Email: info@benchchem.com

[Contact our Ph.D. Support Team for a compatibility check](#)