

Selenium Disulfide: A Technical Guide to its Redox Chemistry and Biological Activity

Author: BenchChem Technical Support Team. **Date:** April 2026

Compound of Interest

Compound Name: Selenium disulfide

CAS No.: 7488-56-4

Cat. No.: B1200345

[Get Quote](#)

For Researchers, Scientists, and Drug Development Professionals

Abstract

Selenium disulfide (SeS₂), a compound with a rich history in dermatology, is gaining increasing attention for its broader therapeutic potential, driven by its unique redox chemistry. This technical guide provides an in-depth exploration of the core redox mechanisms of **selenium disulfide** and its multifaceted biological activities. We delve into its established antifungal and cytostatic properties, as well as its emerging role as an anticancer agent. This document summarizes key quantitative data on its biological efficacy, provides detailed experimental protocols for its study, and visualizes the complex signaling pathways it modulates. This guide is intended to serve as a comprehensive resource for researchers and professionals in drug development seeking to understand and harness the therapeutic capabilities of **selenium disulfide**.

Introduction

Selenium disulfide, a covalent compound of selenium and sulfur, is structurally not a simple molecule but rather a mixture of eight-membered rings with the approximate formula SeS₂.^[1] It

has long been a staple in dermatological formulations for treating conditions like dandruff and seborrheic dermatitis, primarily due to its antifungal and cytostatic effects.[2][3] The biological activity of **selenium disulfide** is intrinsically linked to its redox chemistry, a facet that is now being explored for applications beyond dermatology, most notably in oncology.[4]

The selenium-sulfur bond is highly redox-active and can participate in catalytic biological redox cycles, similar to those observed in enzymes like glutathione peroxidase.[1] This reactivity allows **selenium disulfide** to interact with and modulate the cellular redox environment, influencing a variety of signaling pathways that control cell proliferation, apoptosis, and inflammation. This guide will provide a detailed examination of these properties, offering a technical foundation for further research and development.

Redox Chemistry of Selenium Disulfide

The biological activity of **selenium disulfide** is fundamentally governed by its ability to engage in redox reactions, particularly with thiol-containing molecules such as glutathione (GSH) and cysteine residues in proteins. The selenium-sulfur bond is the key player in this chemistry.

Interaction with Thiols

Selenium compounds are known to react rapidly with thiols.[5] The interaction of **selenium disulfide** with thiols is a critical aspect of its mechanism of action. Selenols (R-SeH) are more acidic and stronger nucleophiles than their corresponding thiols (R-SH).[6] This enhanced nucleophilicity facilitates the attack on disulfide bonds and other electrophilic sites.

The reaction of **selenium disulfide** with thiols like glutathione can lead to the formation of selenotrisulfides (GS-Se-SG) and other reactive selenium and sulfur species.[3][7] This interaction can deplete the intracellular pool of reducing equivalents, such as GSH, leading to a shift in the cellular redox balance towards an oxidative state. This pro-oxidant effect is believed to be a key driver of its anticancer activity.[8]

Catalytic Redox Cycling

Selenium compounds can act as catalysts in redox reactions. For instance, selenocystamine, a diselenide, can be reduced by GSH to a selenol, which then reacts with molecular oxygen to produce superoxide radicals.[9] This catalytic cycle can lead to the consumption of GSH and the generation of reactive oxygen species (ROS), inducing oxidative stress.[9] While the

precise redox potential of **selenium disulfide** is not readily available in the literature, the redox potentials of related selenium compounds have been studied using techniques like cyclic voltammetry.[9][10] For example, the standard redox potential of the $\text{SeO}_4^{2-}/\text{SeO}_3^{2-}$ couple has been determined to be $0.8227 \pm 0.0032\text{V}$ vs. SHE.[9] The redox potential of diselenodiacetic acid is approximately -400 mV vs. the standard hydrogen electrode.[5]

The interaction between selenite and glutathione involves the formation of an unstable selenodiglutathione (GS-Se-SG) intermediate, which then reacts with more GSH to produce glutathione disulfide (GSSG) and elemental selenium.[7] The redox potential of the GSSG/2GSH couple is approximately -250 mV (NHE).[7]

Biological Activity of Selenium Disulfide

The unique redox chemistry of **selenium disulfide** underpins its diverse biological activities, ranging from its well-established dermatological applications to its promising anticancer effects.

Antimicrobial Activity

Selenium disulfide is a potent antifungal agent, particularly effective against *Malassezia* species (formerly *Pityrosporum*), the yeasts implicated in dandruff and seborrheic dermatitis.[2][3] Its mechanism of action is thought to involve the inhibition of fungal growth and interference with sulfur metabolism in fungal cells.[11] **Selenium disulfide** also exhibits antibacterial activity against bacteria such as *Staphylococcus aureus*. [8][12]

Microorganism	Compound	MIC ($\mu\text{g/mL}$)	MBC/MFC (mg/dm^3)	Reference(s)
Malassezia furfur	Selenium Disulfide	2 - 64 (mean = 8)	-	[2]
Malassezia globosa	Selenium Disulfide	1 - 8	-	[4]
Malassezia sympodialis	Selenium Disulfide	-	-	[13]
Staphylococcus aureus	Selenium Disulfide Nanoparticles	-	117.2	[12]
Escherichia coli	Selenium Disulfide Nanoparticles	-	117.2	[12]
Pseudomonas aeruginosa	Selenium Disulfide Nanoparticles	-	117.2	[12]
Candida albicans	Selenium Disulfide Nanoparticles	-	468.8	[12]

Cytostatic and Cytotoxic Activity

Selenium disulfide has a cytostatic effect on epidermal cells, which contributes to its efficacy in treating seborrheic dermatitis by slowing down the turnover of skin cells.[4] More recently, the cytotoxic properties of **selenium disulfide** against cancer cells have become a major area of research.

While specific IC_{50} values for **selenium disulfide** are not extensively reported across a wide range of cancer cell lines, studies on related selenium compounds and selenium nanoparticles demonstrate significant anticancer activity.

Cell Line	Compound	IC ₅₀ (μM)	Reference(s)
Hepatocellular Carcinoma (HCC) cells	Selenium Disulfide	Not specified, but showed significant anti-proliferative effects	[4]
Colon Cancer (HT-29)	Benzodioxyl diselenide	< 12	[13]
Lung Cancer (H1299)	Benzodioxyl diselenide	< 12	[13]
Breast Cancer (MCF-7)	Sodium Selenite	-	[5]
Prostate Cancer (LNCaP)	Methylseleninic acid	-	[14]

Note: The table includes data for related selenium compounds due to the limited availability of specific IC₅₀ values for **selenium disulfide** in the initial search results.

Antioxidant and Pro-oxidant Activities

The role of selenium compounds in the cellular redox environment is complex, exhibiting both antioxidant and pro-oxidant effects depending on the concentration and cellular context.[8] At low concentrations, selenium is a crucial component of antioxidant enzymes like glutathione peroxidases and thioredoxin reductases.[15] However, at higher, supranutritional doses, selenium compounds, including **selenium disulfide**, can act as pro-oxidants, generating ROS and inducing oxidative stress, which can trigger apoptosis in cancer cells.[8]

Assay	Compound	IC ₅₀ / Activity	Reference(s)
DPPH Radical Scavenging	Diacyl diselenide NSAID derivatives	Showed time- and dose-dependent activity	[16]
DPPH Radical Scavenging	Selenium-enriched Penicillium thomii extract	EC ₅₀ values varied with selenium concentration	[17]

Signaling Pathways Modulated by Selenium Disulfide

Selenium disulfide exerts its biological effects by modulating key signaling pathways involved in cell survival, proliferation, and apoptosis.

Inhibition of STAT3 Signaling

Recent research has shown that **selenium disulfide** can disrupt the resistance of hepatocellular carcinoma (HCC) cells to mitochondrial apoptosis by targeting the PLAGL2/C-MET/STAT3 signaling axis.[4] **Selenium disulfide** was found to suppress the phosphorylation of C-MET and STAT3, leading to the downregulation of downstream anti-apoptotic proteins like Bcl-2 and the induction of the intrinsic mitochondrial apoptosis pathway.[4]

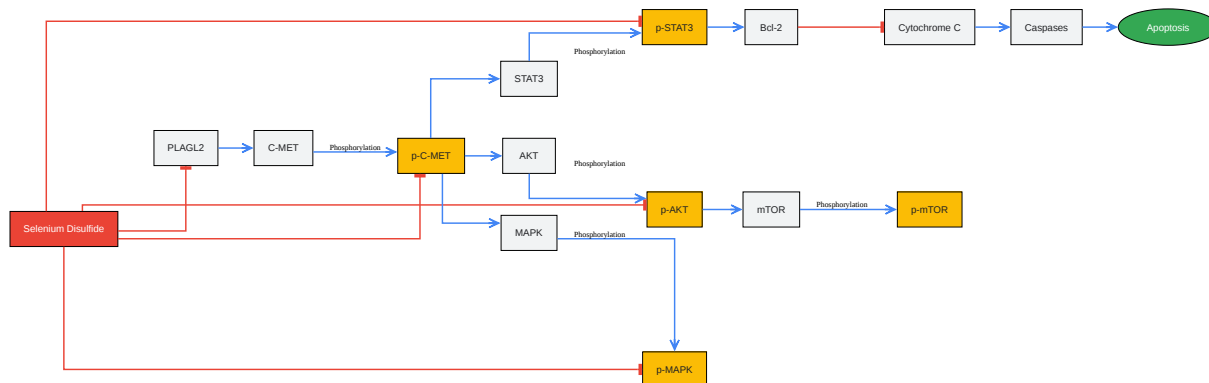

[Click to download full resolution via product page](#)

Figure 1: **Selenium Disulfide** Inhibition of STAT3 Signaling in HCC.

Modulation of NF- κ B Signaling

Selenium compounds have been shown to inhibit the activation of the transcription factor NF- κ B, a key regulator of inflammation.[7][18][19] The activation of NF- κ B is often triggered by oxidative stress. By modulating the cellular redox state, selenium compounds can interfere with the signaling cascade that leads to NF- κ B activation. This involves preventing the degradation of the inhibitory protein I κ B α and blocking the nuclear translocation of the p50 subunit of NF- κ B.[7][20]

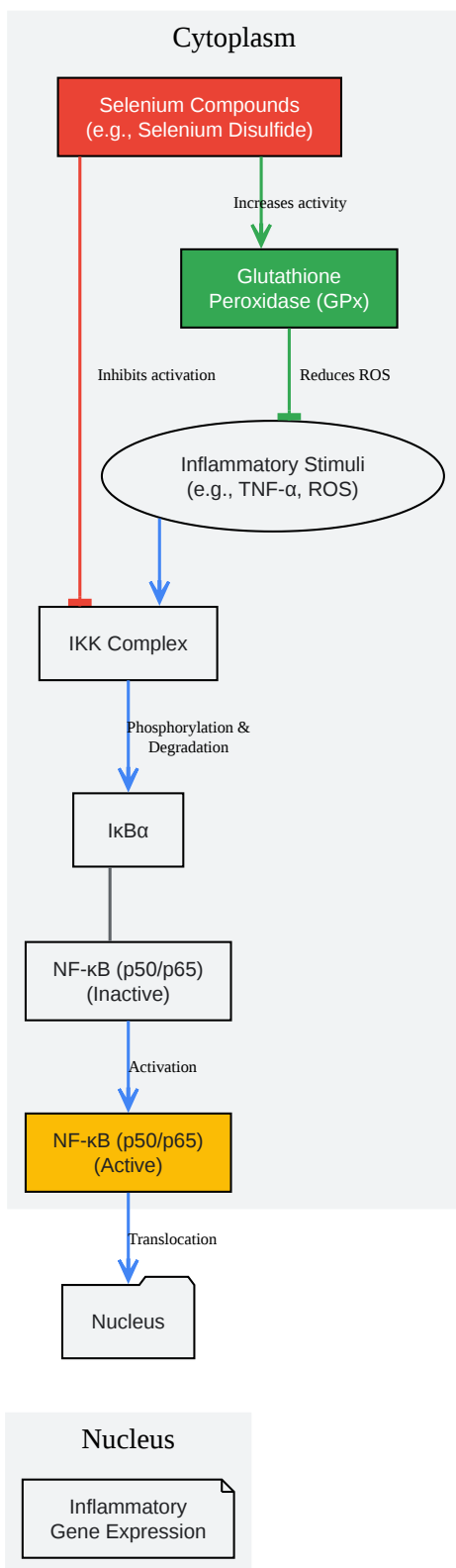

[Click to download full resolution via product page](#)

Figure 2: Modulation of NF-κB Signaling by Selenium Compounds.

Experimental Protocols

This section provides detailed methodologies for key experiments related to the synthesis and biological evaluation of **selenium disulfide**.

Synthesis of Selenium Disulfide Nanoparticles

This protocol describes the synthesis of polysaccharide-stabilized **selenium disulfide** nanoparticles (SPS-SeS₂NPs).[21]

Materials:

- Selenious acid (H₂SeO₃) solution
- Radix saposhnikoviae polysaccharide (SPS) solution
- Ammonium sulfide ((NH₄)₂S) solution (20%)
- Magnetic stirrer with heating
- Deionized water

Procedure:

- Combine equal volumes of H₂SeO₃ solution and SPS solution.
- Stir the mixture continuously for 1 hour at 45°C.
- Add the 20% (NH₄)₂S solution dropwise at a controlled rate while maintaining stirring and temperature to form a nanocolloidal suspension.
- The optimal conditions can be determined by varying the mass ratios of H₂SeO₃ to SPS, H₂SeO₃ to (NH₄)₂S, reaction temperature, and reaction time.[21]

Preparation of Selenium Disulfide Suspension for In Vitro Assays

Due to its poor solubility, preparing a stable suspension of **selenium disulfide** is crucial for in vitro assays.

Materials:

- **Selenium disulfide** powder
- Sterile deionized water or cell culture medium
- A suitable dispersing agent (e.g., carboxymethyl cellulose)[[22](#)]
- Sonicator or homogenizer

Procedure:

- Weigh the desired amount of **selenium disulfide** powder.
- In a sterile container, add a small amount of the dispersing agent to the powder to form a paste.
- Gradually add the sterile water or culture medium while continuously mixing or vortexing to form a suspension.
- Sonicate or homogenize the suspension to reduce particle size and improve stability.
- Visually inspect the suspension for homogeneity before use.

Cytotoxicity Assay (MTT Assay)

The MTT assay is a colorimetric assay for assessing cell metabolic activity, which is an indicator of cell viability.[[23](#)][[24](#)]

Materials:

- Cells of interest
- 96-well plates
- Complete cell culture medium

- **Selenium disulfide** suspension
- MTT (3-(4,5-dimethylthiazol-2-yl)-2,5-diphenyltetrazolium bromide) solution (5 mg/mL in PBS)
- Solubilization solution (e.g., DMSO or a solution of 10% SDS in 0.01 M HCl)
- Microplate reader

Procedure:

- Seed cells in a 96-well plate at a predetermined density and allow them to adhere overnight.
- Treat the cells with various concentrations of the **selenium disulfide** suspension for the desired time period (e.g., 24, 48, or 72 hours). Include untreated control wells.
- After the treatment period, add 10 μ L of MTT solution to each well and incubate for 2-4 hours at 37°C until a purple formazan precipitate is visible.[\[25\]](#)
- Add 100 μ L of the solubilization solution to each well and mix thoroughly to dissolve the formazan crystals.[\[25\]](#)
- Read the absorbance at 570 nm using a microplate reader.
- Calculate cell viability as a percentage of the untreated control.

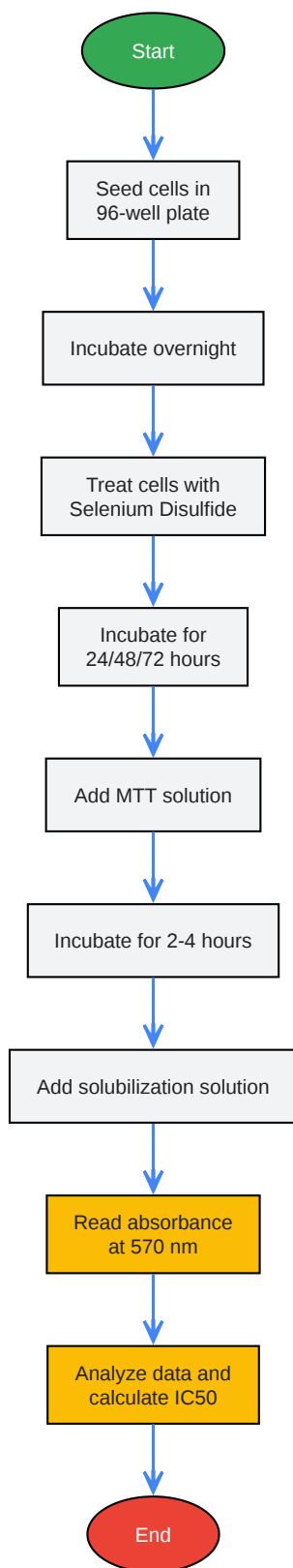

[Click to download full resolution via product page](#)

Figure 3: Experimental Workflow for MTT Cytotoxicity Assay.

Western Blot Analysis for Apoptosis Markers

Western blotting can be used to detect changes in the expression of key apoptosis-related proteins following treatment with **selenium disulfide**.[\[20\]](#)[\[26\]](#)

Materials:

- Treated and untreated cell lysates
- RIPA lysis buffer with protease inhibitors
- BCA protein assay kit
- SDS-PAGE gels
- Transfer buffer
- PVDF or nitrocellulose membrane
- Blocking buffer (e.g., 5% non-fat milk or BSA in TBST)
- Primary antibodies (e.g., anti-Caspase-3, anti-PARP, anti-Bcl-2, anti-Bax)
- HRP-conjugated secondary antibodies
- Chemiluminescent substrate
- Imaging system

Procedure:

- Prepare total protein lysates from treated and untreated cells using RIPA buffer.[\[27\]](#)
- Determine the protein concentration of each lysate using a BCA assay.
- Separate equal amounts of protein (e.g., 20-40 μ g) by SDS-PAGE.[\[28\]](#)
- Transfer the separated proteins to a PVDF or nitrocellulose membrane.

- Block the membrane with blocking buffer for 1 hour at room temperature.
- Incubate the membrane with the primary antibody overnight at 4°C.
- Wash the membrane with TBST and then incubate with the HRP-conjugated secondary antibody for 1 hour at room temperature.
- Wash the membrane again with TBST.
- Add the chemiluminescent substrate and visualize the protein bands using an imaging system.
- Analyze the band intensities to determine changes in protein expression. An increase in cleaved forms of caspases and PARP indicates apoptosis.[20]

Conclusion

Selenium disulfide is a compound with a well-established dermatological profile and a rapidly emerging portfolio of other therapeutic activities, particularly in oncology. Its biological effects are deeply rooted in its redox chemistry, which allows it to interact with and modulate critical cellular pathways. The ability of **selenium disulfide** to induce oxidative stress and apoptosis in cancer cells, while also exhibiting anti-inflammatory and antimicrobial properties, makes it a compelling candidate for further drug development. This technical guide has provided a comprehensive overview of the current understanding of **selenium disulfide**'s redox chemistry and biological activity, along with practical experimental protocols. It is hoped that this resource will facilitate further research into this fascinating and promising therapeutic agent.

Need Custom Synthesis?

BenchChem offers custom synthesis for rare earth carbides and specific isotopic labeling.

Email: info@benchchem.com or [Request Quote Online](#).

References

- [1. researchgate.net \[researchgate.net\]](#)
- [2. researchgate.net \[researchgate.net\]](#)

- [3. Selenium \(Se\) cytotoxicity in drug sensitive and drug resistant murine tumour - PubMed \[pubmed.ncbi.nlm.nih.gov\]](#)
- [4. Selenium Nanoparticles as Candidates for Antibacterial Substitutes and Supplements against Multidrug-Resistant Bacteria - PMC \[pmc.ncbi.nlm.nih.gov\]](#)
- [5. Selenium speciation-dependent cancer radiosensitization by induction of G2/M cell cycle arrest and apoptosis - PMC \[pmc.ncbi.nlm.nih.gov\]](#)
- [6. assets.ctfassets.net \[assets.ctfassets.net\]](#)
- [7. researchgate.net \[researchgate.net\]](#)
- [8. A Selenium Analog of Glutathione. Synthesis and Applications \[jstage.jst.go.jp\]](#)
- [9. researchgate.net \[researchgate.net\]](#)
- [10. mdpi.com \[mdpi.com\]](#)
- [11. First Generation of Antioxidant Precursors for Bioisosteric Se-NSAIDs: Design, Synthesis, and In Vitro and In Vivo Anticancer Evaluation - PMC \[pmc.ncbi.nlm.nih.gov\]](#)
- [12. mdpi.com \[mdpi.com\]](#)
- [13. researchgate.net \[researchgate.net\]](#)
- [14. CN102060277B - Production method of selenium sulfide - Google Patents \[patents.google.com\]](#)
- [15. drugfuture.com \[drugfuture.com\]](#)
- [16. Selenium Nanoparticles as Candidates for Antibacterial Substitutes and Supplements against Multidrug-Resistant Bacteria - PubMed \[pubmed.ncbi.nlm.nih.gov\]](#)
- [17. CN109650353A - A kind of preparation method of high-purity selenium disulfide - Google Patents \[patents.google.com\]](#)
- [18. researchgate.net \[researchgate.net\]](#)
- [19. Antiproliferative Effect of Inorganic and Organic Selenium Compounds in Breast Cell Lines - PMC \[pmc.ncbi.nlm.nih.gov\]](#)
- [20. Apoptosis western blot guide | Abcam \[abcam.com\]](#)
- [21. Selenocysteine in Thiol/Disulfide-Like Exchange Reactions - PMC \[pmc.ncbi.nlm.nih.gov\]](#)
- [22. Can selenenyl sulfides be a substrate of glutathione reductase enzyme? A theoretical insight - PMC \[pmc.ncbi.nlm.nih.gov\]](#)
- [23. repositorio.uc.cl \[repositorio.uc.cl\]](#)
- [24. researchgate.net \[researchgate.net\]](#)

- [25. US3152046A - Selenium disulfide dispersions - Google Patents \[patents.google.com\]](#)
- [26. bio-rad-antibodies.com \[bio-rad-antibodies.com\]](#)
- [27. benchchem.com \[benchchem.com\]](#)
- [28. benchchem.com \[benchchem.com\]](#)
- To cite this document: BenchChem. [Selenium Disulfide: A Technical Guide to its Redox Chemistry and Biological Activity]. BenchChem, [2026]. [Online PDF]. Available at: [\[https://www.benchchem.com/product/b1200345/docs#selenium-disulfide-a-technical-guide-to-its-redox-chemistry-and-biological-activity\]](https://www.benchchem.com/product/b1200345/docs#selenium-disulfide-a-technical-guide-to-its-redox-chemistry-and-biological-activity)

Disclaimer & Data Validity:

The information provided in this document is for Research Use Only (RUO) and is strictly not intended for diagnostic or therapeutic procedures. While BenchChem strives to provide accurate protocols, we make no warranties, express or implied, regarding the fitness of this product for every specific experimental setup.

Technical Support: The protocols provided are for reference purposes. Unsure if this reagent suits your experiment?

Need Industrial/Bulk Grade? [Request Custom Synthesis Quote](#)

BenchChem

Our mission is to be the trusted global source of essential and advanced chemicals, empowering scientists and researchers to drive progress in science and industry.

Contact

Address: 3281 E Guasti Rd

Ontario, CA 91761, United States

Phone: (601) 213-4426

Email: info@benchchem.com

[Contact our Ph.D. Support Team for a compatibility check](#)

