

# Application Notes and Protocols for Quantum Dot Synthesis Using Cadmium Acetate

**Author:** BenchChem Technical Support Team. **Date:** April 2026

## Compound of Interest

Compound Name: Cadmium acetate

CAS No.: 543-90-8

Cat. No.: B1200064

[Get Quote](#)

For Researchers, Scientists, and Drug Development Professionals

These application notes provide detailed protocols and comparative data for the synthesis of semiconductor quantum dots (QDs) using **cadmium acetate** as a cadmium precursor.

**Cadmium acetate** is a commonly used starting material due to its lower toxicity compared to other cadmium sources like cadmium oxide.<sup>[1][2]</sup> The following sections detail established methodologies for the synthesis of Cadmium Selenide (CdSe) and Cadmium Sulfide (CdS) quantum dots, primarily focusing on the prevalent hot-injection technique.

## Overview of the Hot-Injection Synthesis Method

The hot-injection method is a widely adopted technique for producing monodisperse quantum dots. This approach relies on the rapid injection of a precursor solution (the chalcogenide source) into a hot solvent containing the cadmium precursor. This triggers a burst of nucleation events, followed by a controlled growth phase, leading to the formation of quantum dots with a narrow size distribution. Key parameters that influence the final properties of the quantum dots include reaction temperature, precursor concentration, ligand choice, and reaction time.

## Cadmium Precursor Preparation: Cadmium Oleate

In many protocols, **cadmium acetate** is first converted to cadmium oleate, which serves as the active cadmium precursor for quantum dot synthesis.[3] The oleate ligands provide solubility in the high-boiling-point solvents used for the synthesis and also act as surface passivating agents for the growing nanocrystals.[3]

### Protocol for Cadmium Oleate Synthesis from **Cadmium Acetate**

- **Reaction Setup:** In a three-neck round-bottom flask equipped with a condenser, a thermocouple, and a magnetic stir bar, combine **cadmium acetate** dihydrate, oleic acid, and a non-polar solvent like 1-octadecene.[3]
- **Heating and Degassing:** Heat the mixture under an inert atmosphere (e.g., argon or nitrogen) with continuous stirring.[3] A typical temperature for this step is around 130-150°C. This process removes water and acetic acid, byproducts of the reaction between **cadmium acetate** and oleic acid.[3]
- **Completion:** The reaction is typically complete when the solution becomes clear and colorless, indicating the formation of cadmium oleate.[3] The resulting solution can be used directly for quantum dot synthesis or cooled and stored under an inert atmosphere.[3]

## Synthesis of CdSe Quantum Dots

The synthesis of CdSe quantum dots using **cadmium acetate** is well-documented. The following protocol is a common example of the hot-injection method.

### Experimental Protocol: Hot-Injection Synthesis of CdSe QDs

- **Cadmium Precursor Solution:** Prepare a solution of cadmium oleate in 1-octadecene as described in the previous section. For a typical synthesis, a mixture of **cadmium acetate** dihydrate, oleic acid, and 1-octadecene is heated to form the cadmium precursor in situ.[1][2]
- **Selenium Precursor Solution:** In a separate flask, dissolve selenium powder in trioctylphosphine (TOP) with stirring at room temperature to form a TOP-Se solution.[1][2]

- **Reaction Setup:** Heat the cadmium precursor solution in a three-neck flask under an inert atmosphere to a high temperature, typically in the range of 225-280°C.[2]
- **Injection:** Rapidly inject the selenium precursor solution into the hot cadmium precursor solution with vigorous stirring. The color of the solution will change almost instantaneously, indicating the formation of CdSe quantum dots.[4]
- **Growth and Size Tuning:** The size of the quantum dots, and consequently their optical properties (color of emission), can be controlled by the reaction time and temperature.[5] Aliquots of the reaction mixture can be withdrawn at different time intervals to obtain quantum dots of various sizes.[6] Cooling the withdrawn samples in a room temperature vial effectively stops the growth process.[7]
- **Purification:** The synthesized quantum dots are typically purified by precipitation with a non-solvent like methanol or acetone, followed by centrifugation. This process is repeated multiple times to remove unreacted precursors and excess ligands.

#### Quantitative Data for CdSe QD Synthesis

Parameter	Value	Reference
Cadmium Precursor	Cadmium Acetate Dihydrate	[1][2]
Selenium Precursor	Selenium powder in Trioctylphosphine (TOP)	[1][2]
Solvent	1-Octadecene	[1][2]
Ligand	Oleic Acid	[1][2]
Injection Temperature	~225 °C	[2]
Growth Temperature	~225 °C	[7]
Resulting QD Size	2-6 nm (tunable with reaction time)	[2][5]
Photoluminescence	Green to Red (tunable with size)	[5]

## Synthesis of CdS Quantum Dots

Similar to CdSe, CdS quantum dots can be synthesized using **cadmium acetate** as the cadmium source. The sulfur precursor is typically a solution of sulfur powder dissolved in a suitable solvent or a sulfur-containing organic compound.

### Experimental Protocol: Hot-Injection Synthesis of CdS QDs

- **Cadmium Precursor Solution:** Prepare the cadmium oleate solution from **cadmium acetate** dihydrate, oleic acid, and 1-octadecene as previously described.
- **Sulfur Precursor Solution:** Prepare a sulfur precursor by dissolving sulfur powder in a high-boiling-point solvent like 1-octadecene or by using a more reactive sulfur source like bis(trimethylsilyl)sulfide ((TMS)<sub>2</sub>S) dissolved in an organic solvent.
- **Reaction Setup:** Heat the cadmium precursor solution in a three-neck flask under an inert atmosphere to a temperature typically between 200-250°C.
- **Injection:** Swiftly inject the sulfur precursor solution into the hot cadmium precursor solution with vigorous stirring.
- **Growth and Size Tuning:** Monitor the growth of the CdS quantum dots by observing the changes in the absorption and photoluminescence spectra of aliquots taken from the reaction mixture over time.
- **Purification:** Purify the CdS quantum dots using the same precipitation and centrifugation method described for CdSe QDs.

### Quantitative Data for CdS QD Synthesis

Parameter	Value	Reference
Cadmium Precursor	Cadmium Acetate Dihydrate	[8]
Sulfur Precursor	Thiourea or Sodium Sulfide	[8][9]
Solvent	Water or Ethanol (for aqueous synthesis)	[9][10]
Capping Agent	2-Mercaptoethanol or Potato Extract	[8][10]
Reaction Temperature	Room Temperature to 100°C (for aqueous synthesis)	[11]
Resulting QD Size	~5 nm	[10]
Photoluminescence	Blue-Green	[10]

## Visualizing the Synthesis Workflow

The following diagrams illustrate the key steps in the hot-injection synthesis of quantum dots using **cadmium acetate**.

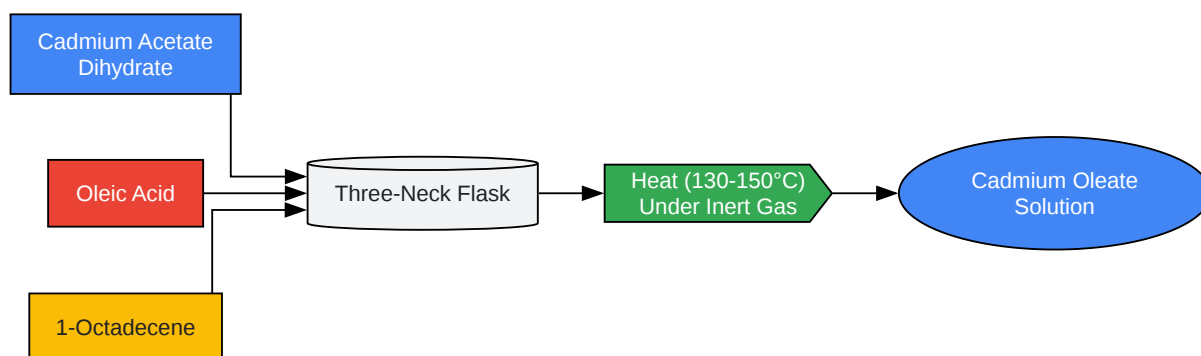

[Click to download full resolution via product page](#)

Caption: Preparation of the Cadmium Oleate Precursor.

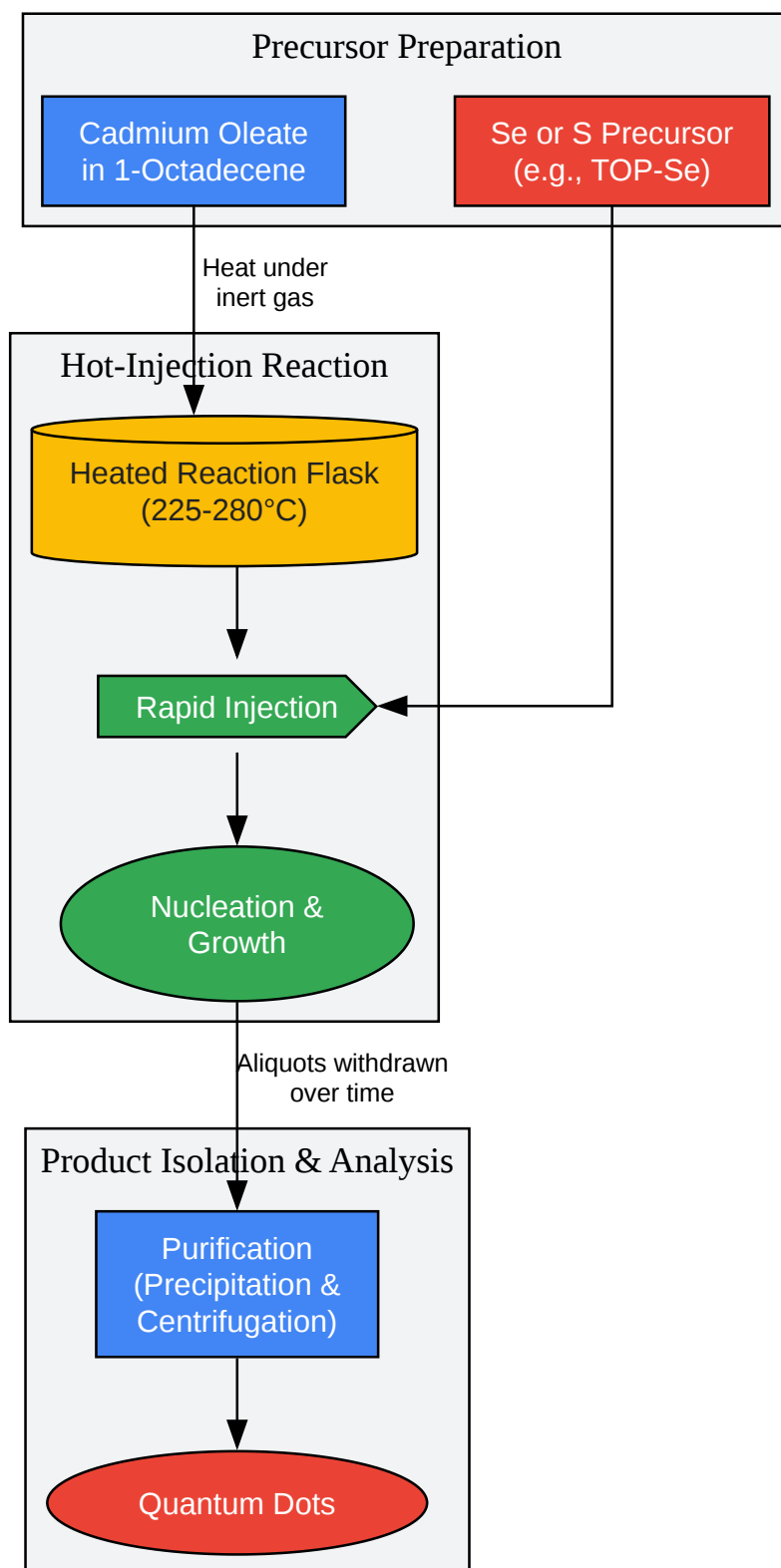

[Click to download full resolution via product page](#)

Caption: Hot-Injection Workflow for Quantum Dot Synthesis.

## Safety Considerations

- Cadmium Compounds: **Cadmium acetate** and the resulting quantum dots are toxic and carcinogenic.[1] Handle these materials with appropriate personal protective equipment (PPE), including gloves, lab coat, and safety glasses, and work in a well-ventilated fume hood.
- Solvents and Reagents: Trioctylphosphine (TOP) is toxic and air-sensitive. 1-octadecene is a high-boiling-point solvent and should be handled with care at elevated temperatures.
- Waste Disposal: All cadmium-containing waste should be collected and disposed of as hazardous waste according to institutional guidelines.[1]

These protocols provide a foundation for the synthesis of high-quality quantum dots using **cadmium acetate**. Researchers are encouraged to consult the primary literature for further details and optimization strategies for specific applications.

### *Need Custom Synthesis?*

*BenchChem offers custom synthesis for rare earth carbides and specific isotopic labeling.*

*Email: [info@benchchem.com](mailto:info@benchchem.com) or [Request Quote Online](#).*

## References

- [1. pubs.acs.org](https://pubs.acs.org) [[pubs.acs.org](https://pubs.acs.org)]
- [2. researchgate.net](https://researchgate.net) [[researchgate.net](https://researchgate.net)]
- [3. benchchem.com](https://benchchem.com) [[benchchem.com](https://benchchem.com)]
- [4. m.youtube.com](https://m.youtube.com) [[m.youtube.com](https://m.youtube.com)]
- [5. asianpubs.org](https://asianpubs.org) [[asianpubs.org](https://asianpubs.org)]
- [6. Synthesis of Cadmium Selenide Quantum Dot Nanoparticles – MRSEC Education Group – UW–Madison](https://education.mrsec.wisc.edu) [[education.mrsec.wisc.edu](https://education.mrsec.wisc.edu)]
- [7. m.youtube.com](https://m.youtube.com) [[m.youtube.com](https://m.youtube.com)]
- [8. researchgate.net](https://researchgate.net) [[researchgate.net](https://researchgate.net)]
- [9. sphinxesai.com](https://sphinxesai.com) [[sphinxesai.com](https://sphinxesai.com)]

- [10. pubs.acs.org \[pubs.acs.org\]](https://pubs.acs.org)
- [11. mdpi.com \[mdpi.com\]](https://mdpi.com)
- To cite this document: BenchChem. [Application Notes and Protocols for Quantum Dot Synthesis Using Cadmium Acetate]. BenchChem, [2026]. [Online PDF]. Available at: [<https://www.benchchem.com/product/b1200064/docs#application-notes-and-protocols-for-quantum-dot-synthesis-using-cadmium-acetate>]

---

### Disclaimer & Data Validity:

The information provided in this document is for Research Use Only (RUO) and is strictly not intended for diagnostic or therapeutic procedures. While BenchChem strives to provide accurate protocols, we make no warranties, express or implied, regarding the fitness of this product for every specific experimental setup.

**Technical Support:** The protocols provided are for reference purposes. Unsure if this reagent suits your experiment?

**Need Industrial/Bulk Grade?** [Request Custom Synthesis Quote](#)

## BenchChem

Our mission is to be the trusted global source of essential and advanced chemicals, empowering scientists and researchers to drive progress in science and industry.

### Contact

Address: 3281 E Guasti Rd  
Ontario, CA 91761, United States  
Phone: (601) 213-4426  
Email: [info@benchchem.com](mailto:info@benchchem.com)

[Contact our Ph.D. Support Team for a compatibility check](#)