

A Comparative Guide to Rapid Sample Preparation for Selenium Analysis

Author: BenchChem Technical Support Team. **Date:** April 2026

Compound of Interest

Compound Name: *Selenium disulfide*

CAS No.: *7488-56-4*

Cat. No.: *B1200345*

[Get Quote](#)

For researchers, scientists, and drug development professionals, accurate and efficient analysis of selenium is critical. The sample preparation step, designed to digest the sample matrix and solubilize the analyte, is often the most time-consuming and error-prone stage of the entire analytical process. This guide provides an objective comparison of a rapid sample preparation method, microwave-assisted digestion, with traditional techniques like wet acid digestion and dry ashing, supported by experimental data to facilitate an informed choice of methodology.

Performance Comparison of Digestion Methods

The selection of an appropriate digestion method is a trade-off between speed, efficiency, and the specific requirements of the analysis. The following table summarizes the key performance parameters of different methods based on validation studies.

Parameter	Microwave-Assisted Digestion	Wet Acid Digestion (Open Vessel)	Dry Ashing	UV-Assisted Digestion
Digestion Time	20 - 40 minutes	4 - 16 hours	~8 hours	60 - 120 minutes
Accuracy (Recovery %)	95% - 105%	87% - 109%	Generally good, but can have losses	96% - 112% (for various elements)
Precision (%RSD)	< 2.0%	5% - 17%	Can be >10%	Good, but matrix dependent
Contamination Risk	Low (closed system)	High (open system)	High (open system)	Low (closed system)
Throughput	High	Low	Low	Moderate
Safety	High (contained system)	Lower (use of strong acids at high temps)	Moderate	High

Experimental Workflows

The general workflow for selenium analysis involves sample digestion followed by detection using techniques like Inductively Coupled Plasma-Optical Emission Spectrometry (ICP-OES) or Atomic Absorption Spectrometry (AAS). The key difference lies in the digestion step.

General Workflow for Selenium Analysis

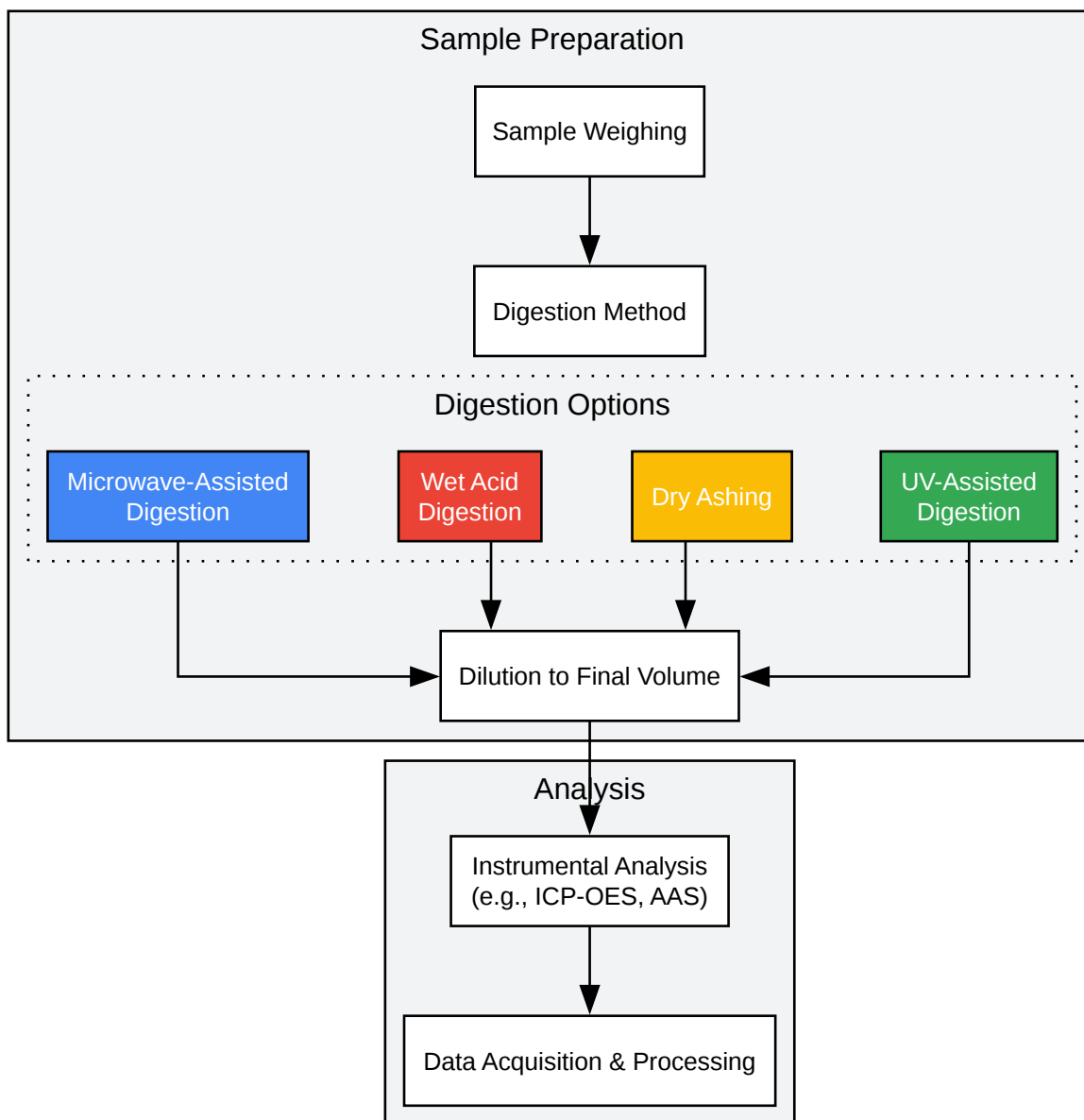

[Click to download full resolution via product page](#)

Workflow for Selenium Analysis

Experimental Protocols

Below are detailed methodologies for the key digestion techniques discussed.

Microwave-Assisted Digestion (Rapid Method)

This method utilizes microwave energy to rapidly heat the sample and acid mixture in a closed, pressurized vessel, significantly reducing the digestion time.

Protocol:

- Weigh approximately 0.25 g of the homogenized sample into a clean microwave digestion vessel.
- In a fume hood, add 9 mL of concentrated nitric acid (HNO_3) and 3 mL of hydrofluoric acid (HF) to the vessel. For samples with high organic content, 2 mL of 30% hydrogen peroxide (H_2O_2) can be added to aid digestion.
- Seal the vessels and place them in the microwave digestion system.
- The temperature program should ramp to 200°C over 20 minutes and hold for 5-15 minutes.
- After the program is complete, allow the vessels to cool to room temperature.
- Carefully uncap the vessels in a fume hood.
- Quantitatively transfer the digested sample to a volumetric flask and dilute to the final volume with deionized water.

Microwave-Assisted Digestion Workflow

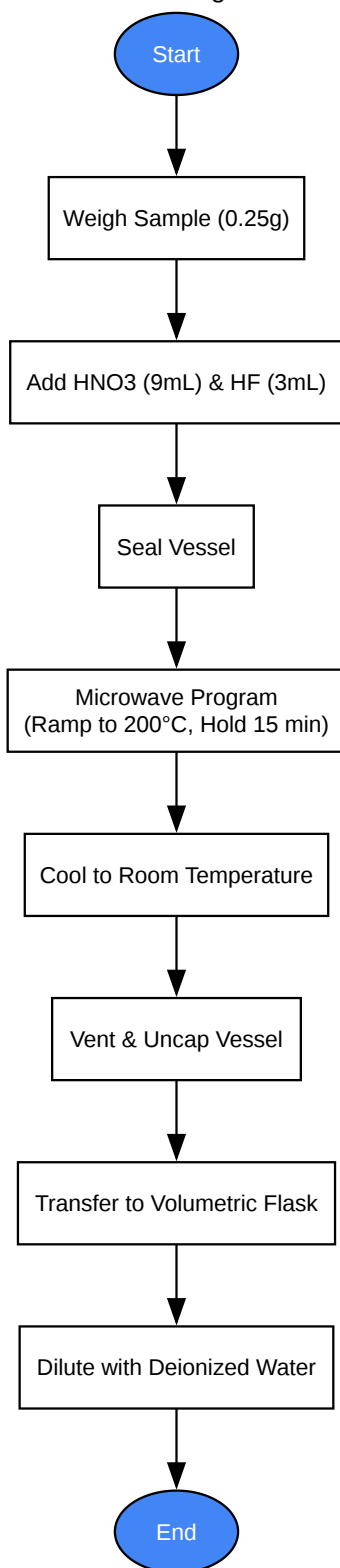

[Click to download full resolution via product page](#)

Microwave Digestion Workflow

Wet Acid Digestion (Conventional Method)

This traditional method involves heating the sample with a mixture of strong acids in an open or partially covered vessel on a hot plate.

Protocol:

- Weigh approximately 0.25-0.30 g of the sample into a 100 mL tall form beaker.
- Under a fume hood, add 10 mL of 16 M nitric acid (HNO_3) and 2 mL of 6 M hydrochloric acid (HCl). For biological samples, a mixture of nitric acid and perchloric acid (HClO_4) is also common.
- Cover the beaker with a watch glass and heat on a hot plate at a low temperature for several hours or overnight, ensuring the sample does not boil dry.
- Remove the watch glass and continue heating to evaporate the acid until the sample is nearly dry.
- After cooling, add 10 mL of 12 M hydrochloric acid and heat for at least 15 minutes to ensure the conversion of Se(VI) to Se(IV).
- Cool the digest and transfer it to a volumetric flask, then dilute to the mark with deionized water.

UV-Assisted Digestion

This technique uses UV radiation to generate highly reactive radicals that oxidize the organic matrix. It is particularly useful for liquid samples with low to moderate organic content.

Protocol:

- Pipette 10 mL of the water sample into a quartz sample vessel.
- Add 10 μL of hydrochloric acid (HCl) and 50 μL of 30% hydrogen peroxide (H_2O_2).
- Place the vessel in the UV digester and irradiate at 90°C for 60 minutes.

- If the reduction of Se(VI) to Se(IV) is necessary, adjust the pH of the solution to 7-9 with NaOH and irradiate for another 60 minutes at 90°C.

Conclusion

For laboratories prioritizing high throughput, safety, and minimal contamination, microwave-assisted digestion presents a validated and superior alternative to traditional methods for selenium analysis. Its ability to achieve complete digestion in a fraction of the time, coupled with high accuracy and precision, makes it an ideal choice for researchers, scientists, and drug development professionals. While conventional wet acid digestion can yield accurate results, it is significantly more time-consuming and carries a higher risk of contamination. Dry ashing is generally the least favorable due to longer processing times and potential for analyte loss. UV-assisted digestion is a viable option for simpler liquid matrices

- To cite this document: BenchChem. [A Comparative Guide to Rapid Sample Preparation for Selenium Analysis]. BenchChem, [2026]. [Online PDF]. Available at: [\[https://www.benchchem.com/product/b1200345/docs#a-comparative-guide-to-rapid-sample-preparation-for-selenium-analysis\]](https://www.benchchem.com/product/b1200345/docs#a-comparative-guide-to-rapid-sample-preparation-for-selenium-analysis)

Disclaimer & Data Validity:

The information provided in this document is for Research Use Only (RUO) and is strictly not intended for diagnostic or therapeutic procedures. While BenchChem strives to provide accurate protocols, we make no warranties, express or implied, regarding the fitness of this product for every specific experimental setup.

Technical Support: The protocols provided are for reference purposes. Unsure if this reagent suits your experiment?

Need Industrial/Bulk Grade? [Request Custom Synthesis Quote](#)

BenchChem

Our mission is to be the trusted global source of essential and advanced chemicals, empowering scientists and researchers to drive progress in science and industry.

Contact

Address: 3281 E Guasti Rd

Ontario, CA 91761, United States

Phone: (601) 213-4426

Email: info@benchchem.com

[Contact our Ph.D. Support Team for a compatibility check](#)