

Application Notes and Protocols for the Continuous Flow Synthesis of α -Nitrostilbene

Author: BenchChem Technical Support Team. **Date:** May 2026

Compound of Interest

Compound Name: *Stilbene, alpha-nitro-*

CAS No.: 1215-07-2

Cat. No.: B120486

[Get Quote](#)

Introduction: Embracing Continuous Flow for the Efficient Synthesis of α -Nitrostilbene

α -Nitrostilbene and its derivatives are pivotal intermediates in the synthesis of a wide array of pharmacologically active compounds and functional materials. The conventional batch production of these compounds, however, is often beset by challenges related to reaction control, safety, and scalability. Continuous flow chemistry emerges as a powerful enabling technology to overcome these limitations, offering superior heat and mass transfer, enhanced safety profiles for handling potentially hazardous intermediates, and a streamlined path to scale-up.[1][2] This application note provides a comprehensive guide for researchers, scientists, and drug development professionals on the synthesis of α -nitrostilbene utilizing continuous flow methodologies. We will delve into the mechanistic underpinnings of the synthetic strategy, present detailed, field-proven protocols, and discuss key optimization and scale-up considerations, all grounded in authoritative scientific literature.

The synthesis of α -nitrostilbene is typically achieved through a two-step sequence: a base-catalyzed Henry (nitroaldol) reaction between benzaldehyde and phenylnitromethane to form a β -nitro alcohol intermediate, followed by dehydration to yield the target α -nitrostilbene. This

guide will focus on translating this well-established reaction sequence into a robust and efficient continuous flow process.

Scientific Principles and Mechanistic Insights

The core of this synthetic approach lies in the Henry reaction, a classic carbon-carbon bond-forming reaction.[3] The reaction commences with the deprotonation of the nitroalkane (phenylnitromethane) at the α -carbon by a base, forming a nucleophilic nitronate. This nitronate then attacks the electrophilic carbonyl carbon of benzaldehyde. The subsequent protonation of the resulting alkoxide furnishes the β -nitro alcohol.

Mechanism of the Henry Reaction:

- Deprotonation: A base abstracts an acidic α -proton from phenylnitromethane to generate a resonance-stabilized nitronate anion.
- Nucleophilic Addition: The carbon-centered nucleophile of the nitronate attacks the carbonyl carbon of benzaldehyde.
- Protonation: The resulting β -nitro alkoxide is protonated to yield the β -nitro alcohol.

All steps in the Henry reaction are reversible, which can limit yields in batch processes.[4] Flow chemistry, with its ability to precisely control reaction time and rapidly remove the product from the reaction environment, can help to drive the reaction towards completion.

The subsequent dehydration of the β -nitro alcohol to α -nitrostilbene is typically acid or base-catalyzed and proceeds through an elimination mechanism. In a continuous flow setup, this step can be integrated sequentially, creating a telescoped synthesis that minimizes manual handling and improves overall efficiency.[5]

Visualizing the Synthetic Workflow

To provide a clear overview of the continuous flow process for α -nitrostilbene synthesis, the following diagrams illustrate the key stages.

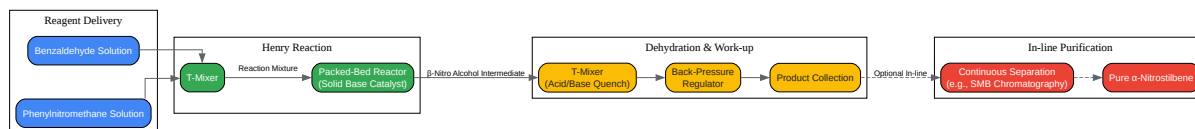

[Click to download full resolution via product page](#)

Caption: High-level workflow for the continuous synthesis of α -nitrostilbene.

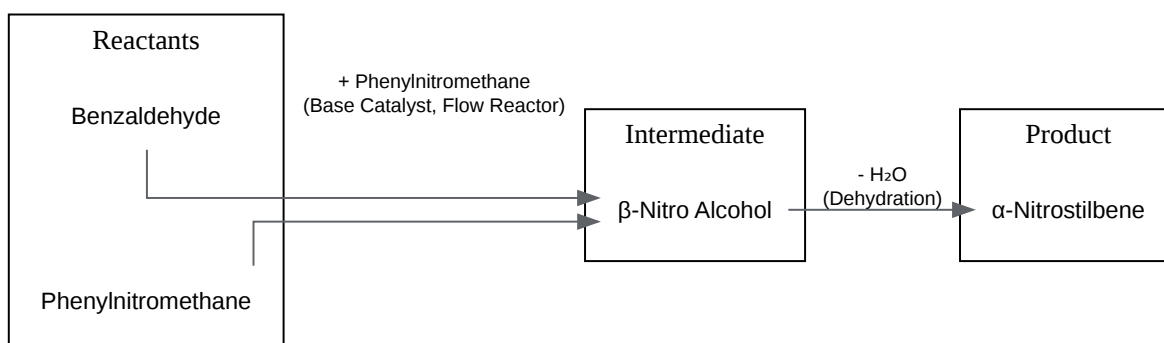

[Click to download full resolution via product page](#)

Caption: Chemical transformation pathway from reactants to the final product.

Experimental Protocols

The following protocols provide a detailed, step-by-step methodology for the continuous flow synthesis of α -nitrostilbene.

Protocol 1: Packed-Bed Reactor Setup and Catalyst Packing

The use of a packed-bed reactor with a heterogeneous catalyst is highly advantageous for continuous flow synthesis as it simplifies product purification by retaining the catalyst within the reactor.^{[2][6]}

Materials:

- Omnifit® glass column (e.g., 6.6 mm ID x 100 mm length) or similar
- Frits (porosity appropriate for the catalyst particle size)
- Amino-functionalized silica gel (or other suitable solid-supported base)
- HPLC pump
- Tubing (PTFE or PFA) and fittings

Procedure:

- **Column Assembly:** Securely fit one frit at the bottom outlet of the glass column.
- **Catalyst Slurry Preparation:** Create a slurry of the amino-functionalized silica gel in the reaction solvent (e.g., ethanol or acetonitrile).
- **Packing the Column:** Carefully pour the catalyst slurry into the column. Gently tap the column to ensure even packing and avoid the formation of channels.
- **Securing the Catalyst Bed:** Once the desired bed height is achieved, allow the solvent to drain to the top of the catalyst bed and place the second frit on top of the bed. Secure the top fitting of the column.
- **System Equilibration:** Connect the packed column to the flow system and pump the solvent through the column at a low flow rate until the system is fully wetted and free of air bubbles.

Protocol 2: Continuous Flow Henry Reaction and In-situ Dehydration

This protocol details the continuous synthesis of α -nitrostilbene through a telescoped Henry reaction and dehydration sequence.

Reagent Preparation:

- Solution A (Benzaldehyde): Prepare a 0.5 M solution of benzaldehyde in ethanol.
- Solution B (Phenylnitromethane): Prepare a 0.5 M solution of phenylnitromethane in ethanol.
- Solution C (Dehydrating Agent - Optional): Prepare a solution of a suitable dehydrating agent (e.g., methanesulfonyl chloride with triethylamine in ethanol) if a separate dehydration step is desired.

Flow System Setup:

- Connect two separate HPLC pumps, one for Solution A and one for Solution B, to a T-mixer.
- Connect the outlet of the T-mixer to the inlet of the packed-bed reactor.
- The outlet of the packed-bed reactor can be directed to another T-mixer for the introduction of the dehydrating agent (if used) or directly to a back-pressure regulator (BPR).
- Place a BPR (e.g., 100 psi) after the reactor to maintain a stable flow and prevent solvent outgassing.
- The outlet of the BPR is directed to a collection vessel.

Reaction Execution:

- Initiate Flow: Start pumping Solution A and Solution B at equal flow rates (e.g., 0.1 mL/min each, for a total flow rate of 0.2 mL/min). This corresponds to a 1:1 stoichiometry.
- Set Reaction Temperature: If required, the packed-bed reactor can be heated using a column heater. For many base-catalyzed Henry reactions, room temperature is sufficient.

- **Achieve Steady State:** Allow the system to run for at least three reactor volumes to reach a steady state before collecting the product.
- **Product Collection:** Collect the product stream in a suitable vessel.
- **In-situ Dehydration:** The basic conditions within the packed-bed reactor may be sufficient to induce spontaneous dehydration of the β -nitro alcohol intermediate to the α -nitrostilbene product. Monitor the reaction output by TLC or LC-MS to determine the product distribution.
- **Shutdown:** Upon completion, flush the system with fresh solvent to remove all reactants and products.

Data Presentation: Optimization of Reaction Parameters

The optimization of reaction parameters is crucial for maximizing yield and purity in a continuous flow process.^{[7][8]} A design of experiments (DoE) approach can be systematically employed to explore the reaction space.

Parameter	Range Explored	Optimal Value (Example)	Effect on Yield and Purity
Temperature (°C)	25 - 80	40	Higher temperatures may accelerate both the Henry reaction and dehydration but can also lead to side product formation.
Total Flow Rate (mL/min)	0.1 - 1.0	0.2	Affects residence time. Lower flow rates (longer residence time) generally lead to higher conversion.
Stoichiometry (Benzaldehyde:Phenyl nitromethane)	1:1 to 1:1.5	1:1.2	A slight excess of the nitroalkane can drive the reaction to completion.
Solvent	Ethanol, Acetonitrile, THF	Ethanol	Solvent choice can influence reactant solubility and catalyst activity. ^[9]

Purification and Scale-Up Strategies

In-line and Continuous Purification

For high-purity α -nitrostilbene required in drug development, integrating a continuous purification step is highly desirable.^{[10][11]}

- **Liquid-Liquid Extraction:** A continuous liquid-liquid extraction can be performed using a membrane separator or a centrifugal contactor to remove water-soluble impurities.
- **Continuous Crystallization:** If the product is crystalline, a continuous crystallization setup can be designed to isolate the pure compound.^[11]

- Simulated Moving Bed (SMB) Chromatography: For challenging separations, SMB chromatography offers a continuous and efficient method for isolating the target compound with high purity.

Scale-Up Considerations

Scaling up a continuous flow process is typically more straightforward than scaling up a batch reaction.[\[12\]](#)

- Scaling-Up: For a tubular or packed-bed reactor, increasing the production can be achieved by simply running the system for a longer duration.
- Numbering-Up: To increase throughput, multiple reactor systems can be run in parallel. This approach avoids the need for re-optimization of reaction conditions that is often required when scaling up the volume of a batch reactor.[\[12\]](#)

Conclusion: A Superior Approach to α -Nitrostilbene Synthesis

The application of continuous flow chemistry to the synthesis of α -nitrostilbene offers significant advantages over traditional batch methods. The enhanced control over reaction parameters, improved safety, and streamlined scalability make it an ideal platform for both academic research and industrial drug development. The protocols and insights provided in this application note serve as a robust starting point for scientists to implement and optimize the continuous flow synthesis of this valuable chemical intermediate, paving the way for more efficient and sustainable chemical manufacturing.

References

- Continuous Flow Technology as an Enabler for Innovative Transformations Exploiting Carbenes, Nitrenes, and Benzynes. (2022). PMC - NIH. [\[Link\]](#)
- Continuous-flow synthesis of primary amines: Metal-free reduction of aliphatic and aromatic nitro derivatives with trichlorosilane. (n.d.). Beilstein Journals. [\[Link\]](#)
- Continuous flow photocyclization of stilbenes – scalable synthesis of functionalized phenanthrenes and helicenes. (n.d.). Beilstein Journals. [\[Link\]](#)

- Continuous Flow Chemistry: A Novel Technology for the Synthesis of Marine Drugs. (n.d.). NIH. [\[Link\]](#)
- Henry reaction - Wikipedia. (n.d.). Wikipedia. [\[Link\]](#)
- (PDF) Continuous-flow synthesis of primary amines: Metal-free reduction of aliphatic and aromatic nitro derivatives with trichlorosilane. (2016). ResearchGate. [\[Link\]](#)
- Henry Reaction between Benzaldehyde and Nitromethane over Solid Base Catalysts: A Green Protocol. (n.d.). SciRP.org. [\[Link\]](#)
- Figure 6. Scale-up strategies for tubular flow reactors: numbering up,... (n.d.). ResearchGate. [\[Link\]](#)
- Inline purification in continuous flow synthesis – opportunities and challenges. (n.d.). BJOC. [\[Link\]](#)
- Heterogeneous Organocatalysts for Light-Driven Reactions in Continuous Flow. (2024). MDPI. [\[Link\]](#)
- Regioselective Synthesis of α -Functional Stilbenes via Precise Control of Rapid cis- trans Isomerization in Flow. (2021). PubMed. [\[Link\]](#)
- Efficient optimization and synthesis of diverse azaarenes via nitrogen atom insertion under continuous flow conditions. (n.d.). Chemical Communications (RSC Publishing). [\[Link\]](#)
- Henry Reaction between Benzaldehyde and Nitromethane over Solid Base Catalysts: A Green Protocol. (2018). ResearchGate. [\[Link\]](#)
- Catalysis in Flow. (n.d.). The Kappe Laboratory. [\[Link\]](#)
- (PDF) Inline purification in continuous flow synthesis – opportunities and challenges. (2022). ResearchGate. [\[Link\]](#)
- When it comes to scaling up organic synthesis, it pays to think small. James Mitchell Crow explains. (n.d.). Royal Society of Chemistry. [\[Link\]](#)

- Optimizing Henry reaction conditions (substituted benzaldehydes + nitromethane). (2017). Sciencemadness Discussion Board. [\[Link\]](#)
- Henry Reaction between Benzaldehyde and Nitromethane over Solid Base Catalysts: A Green Protocol. (2018). Semantic Scholar. [\[Link\]](#)
- Heterogenous Reactions with Solids in Flow. (n.d.). Chemical Industry Journal. [\[Link\]](#)
- Unveiling Reliable Catalysts for the Asymmetric Nitroaldol (Henry) Reaction**. (2004). University of Windsor. [\[Link\]](#)
- 1. Reactors: Goal, Design & Characterization 3. Published applications in Corning AFR. (n.d.). Corning. [\[Link\]](#)
- Automated Optimization under Dynamic Flow Conditions. (n.d.). ChemRxiv. [\[Link\]](#)
- Automated Optimization of a Multistep, Multiphase Continuous Flow Process for Pharmaceutical Synthesis. (2024). PMC - NIH. [\[Link\]](#)
- (PDF) Heterogeneous Catalysis Under Flow for the 21st Century Fine Chemical Industry. (2019). ResearchGate. [\[Link\]](#)
- Asymmetric Henry Reaction of Nitromethane with Substituted Aldehydes Catalyzed by Novel In Situ Generated Chiral Bis(β -Amino Alcohol-Cu(OAc)₂). (2021). MDPI. [\[Link\]](#)
- Continuous Flow Synthesis of Nitrofuran Pharmaceuticals Using Acetyl Nitrate. (2025). PubMed. [\[Link\]](#)
- Chemical reaction engineering, process design and scale-up issues at the frontier of synthesis: flow chemistry. (n.d.). AIR Unimi. [\[Link\]](#)
- Continuous flow multi-step organic synthesis. (2010). RSC Publishing. [\[Link\]](#)

Need Custom Synthesis?

BenchChem offers custom synthesis for rare earth carbides and specific isotopic labeling.

Email: info@benchchem.com or [Request Quote Online](#).

Sources

- 1. Regioselective Synthesis of α -Functional Stilbenes via Precise Control of Rapid cis- trans Isomerization in Flow - PubMed [pubmed.ncbi.nlm.nih.gov]
- 2. Heterogenous Reactions with Solids in Flow - Chemical Industry Journal [chemicalindustryjournal.co.uk]
- 3. air.unimi.it [air.unimi.it]
- 4. researchgate.net [researchgate.net]
- 5. Catalysis in Flow – The Kappe Laboratory [goflow.at]
- 6. Efficient optimization and synthesis of diverse azaarenes via nitrogen atom insertion under continuous flow conditions - Chemical Communications (RSC Publishing) [pubs.rsc.org]
- 7. Automated Optimization of a Multistep, Multiphase Continuous Flow Process for Pharmaceutical Synthesis - PMC [pmc.ncbi.nlm.nih.gov]
- 8. mdpi.com [mdpi.com]
- 9. BJOC - Inline purification in continuous flow synthesis – opportunities and challenges [beilstein-journals.org]
- 10. researchgate.net [researchgate.net]
- 11. researchgate.net [researchgate.net]
- 12. rsc.org [rsc.org]
- To cite this document: BenchChem. [Application Notes and Protocols for the Continuous Flow Synthesis of α -Nitrostilbene]. BenchChem, [2026]. [Online PDF]. Available at: [<https://www.benchchem.com/product/b120486/docs#application-notes-and-protocols-for-the-continuous-flow-synthesis-of-nitrostilbene>]

Disclaimer & Data Validity:

The information provided in this document is for Research Use Only (RUO) and is strictly not intended for diagnostic or therapeutic procedures. While BenchChem strives to provide accurate protocols, we make no warranties, express or implied, regarding the fitness of this product for every specific experimental setup.

Technical Support: The protocols provided are for reference purposes. Unsure if this reagent suits your experiment?

Need Industrial/Bulk Grade? [Request Custom Synthesis Quote](#)

BenchChem

Our mission is to be the trusted global source of essential and advanced chemicals, empowering scientists and researchers to drive progress in science and industry.

Contact

Address: 3281 E Guasti Rd
Ontario, CA 91761, United States
Phone: (601) 213-4426
Email: info@benchchem.com

[Contact our Ph.D. Support Team for a compatibility check](#)