

# Methyltributylammonium Iodide: A Comprehensive Guide for Researchers and Drug Development Professionals

**Author:** BenchChem Technical Support Team. **Date:** May 2026

## Compound of Interest

Compound Name:	Methyltributylammonium iodide
CAS No.:	3085-79-8
Cat. No.:	B1199620

[Get Quote](#)

**Methyltributylammonium iodide** (MTBAI) is a quaternary ammonium salt that has garnered significant interest as a versatile ionic liquid and phase-transfer catalyst. Its unique combination of a bulky, lipophilic cation and a nucleophilic anion makes it a powerful tool in a variety of chemical transformations. This guide provides an in-depth exploration of MTBAI's properties and its practical applications in organic synthesis and electrochemistry, complete with detailed protocols and expert insights to empower researchers in their experimental endeavors.

## Physicochemical Properties and Safety Considerations

A thorough understanding of the physical and chemical characteristics of **methyltributylammonium iodide** is paramount for its effective and safe utilization.

### Key Physicochemical Data

The properties of MTBAI, such as its solubility, viscosity, and electrochemical stability, are crucial for designing and optimizing reactions. While extensive data for MTBAI is not always

readily available, we can infer some properties from its chloride analogue and related quaternary ammonium salts.

Property	Value	References
Molecular Formula	C <sub>13</sub> H <sub>30</sub> IN	[1]
Molecular Weight	327.29 g/mol	[1]
Appearance	White to light yellow powder or crystals	-
Melting Point	95-99 °C (for the chloride analogue)	[2]
Solubility	Soluble in water. Soluble in polar organic solvents like acetonitrile, methanol, and DMSO.[3]	[2][3]
Viscosity	Moderate to high; decreases with increasing temperature.[4]	[4]
Electrochemical Window	Expected to be wide, similar to other quaternary ammonium-based ionic liquids. For a related R <sub>4</sub> NNTf <sub>2</sub> ionic liquid, the window is reported as +1.5 to -3 V vs Ag/Ag <sup>+</sup> . [5]	[5]

Note: The viscosity of ionic liquids is highly dependent on temperature and the presence of impurities, particularly water.[4] It is recommended to dry the ionic liquid under vacuum before use in moisture-sensitive applications.

## Safety and Handling

**Methyltributylammonium iodide** is classified as an irritant.[6] Proper handling procedures are essential to ensure laboratory safety.

- Hazard Statements:

- H315: Causes skin irritation.[6]
- H319: Causes serious eye irritation.[6]
- H335: May cause respiratory irritation.[6]
- Precautionary Statements:
  - P261: Avoid breathing dust/fume/gas/mist/vapors/spray.[6]
  - P264: Wash skin thoroughly after handling.[6]
  - P280: Wear protective gloves/protective clothing/eye protection/face protection.[6]
  - P302 + P352: IF ON SKIN: Wash with plenty of soap and water.[6]
  - P305 + P351 + P338: IF IN EYES: Rinse cautiously with water for several minutes. Remove contact lenses, if present and easy to do. Continue rinsing.[6]

Disposal: Dispose of contents/container to an approved waste disposal plant in accordance with local regulations.[6]

## Synthesis of Methyltributylammonium Iodide

The synthesis of **methyltributylammonium iodide** is a straightforward process, typically achieved through a Menshutkin reaction, which involves the quaternization of a tertiary amine with an alkyl halide.[7]

### Synthesis Protocol

This protocol describes the synthesis of **methyltributylammonium iodide** from tributylamine and methyl iodide.

Materials:

- Tributylamine
- Methyl iodide[8]

- A polar aprotic solvent (e.g., acetone or acetonitrile)
- Round-bottom flask with a reflux condenser
- Magnetic stirrer and heating mantle
- Rotary evaporator
- Diethyl ether (for washing)

Procedure:

- In a round-bottom flask, dissolve tributylamine (1 equivalent) in the chosen polar aprotic solvent.
- Slowly add methyl iodide (1.1 equivalents) to the solution while stirring. The reaction is exothermic, so controlled addition is important.
- Heat the reaction mixture to a gentle reflux and maintain for several hours. The progress of the reaction can be monitored by thin-layer chromatography (TLC) or gas chromatography (GC).
- After the reaction is complete, cool the mixture to room temperature.
- Remove the solvent using a rotary evaporator.
- The resulting solid is the crude **methyltributylammonium iodide**. Wash the solid with diethyl ether to remove any unreacted starting materials.
- Dry the purified product under vacuum.

Diagram of the Synthesis Workflow:

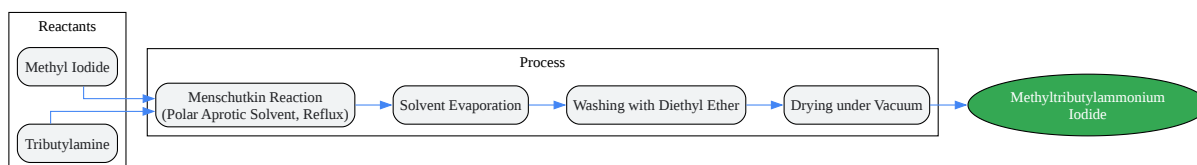

[Click to download full resolution via product page](#)

Caption: Workflow for the synthesis of **Methyltributylammonium Iodide**.

## Applications in Organic Synthesis: Phase-Transfer Catalysis

**Methyltributylammonium iodide** excels as a phase-transfer catalyst (PTC), facilitating reactions between reactants in immiscible phases.[9] The lipophilic tributyl groups on the cation allow it to transport the iodide anion (or other nucleophiles after anion exchange) from an aqueous phase into an organic phase where the substrate resides.[9]

## Mechanism of Phase-Transfer Catalysis

The catalytic cycle involves the transfer of the nucleophile to the organic phase, reaction with the substrate, and regeneration of the catalyst.

Diagram of the PTC Mechanism:

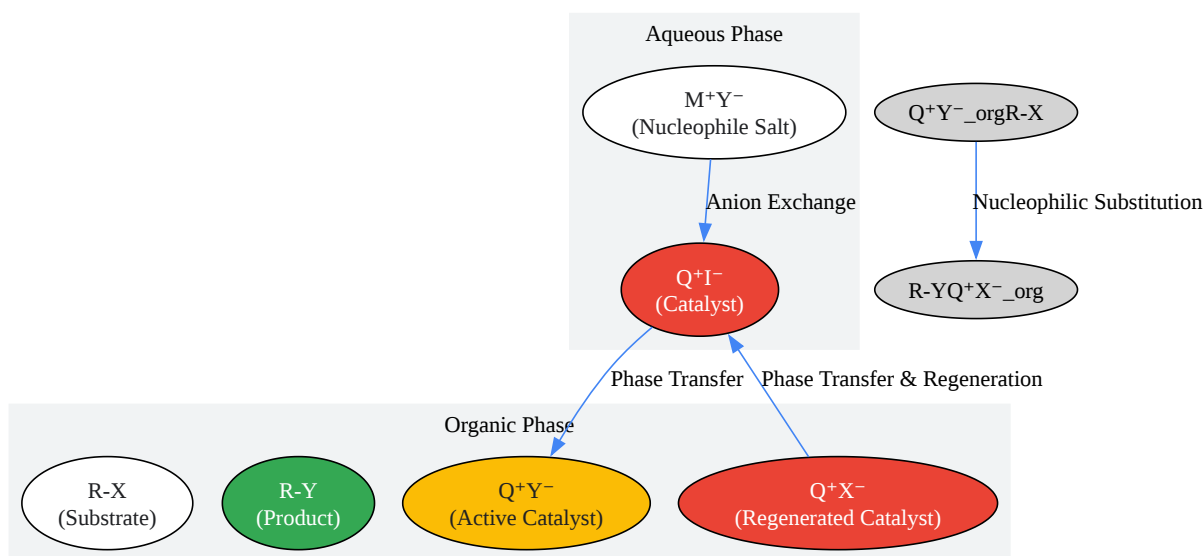

[Click to download full resolution via product page](#)

Caption: Mechanism of phase-transfer catalysis using MTBAI.

## Protocol: Nucleophilic Substitution of an Alkyl Halide

This protocol details the cyanation of 1-bromooctane using sodium cyanide, catalyzed by **methyltributylammonium iodide**. This reaction is a classic example of a nucleophilic substitution that is significantly accelerated by PTC.[9][10]

Materials:

- 1-Bromooctane
- Sodium cyanide (NaCN)
- **Methyltributylammonium iodide (MTBAI)**

- Toluene
- Water
- Round-bottom flask with a reflux condenser and mechanical stirrer
- Heating mantle
- Separatory funnel
- Anhydrous magnesium sulfate ( $\text{MgSO}_4$ )
- Rotary evaporator

Procedure:

- Set up a round-bottom flask with a reflux condenser and a mechanical stirrer.
- Charge the flask with 1-bromooctane (1 equivalent), sodium cyanide (1.5 equivalents), and **methyltributylammonium iodide** (0.05 equivalents).
- Add toluene and water to create a biphasic system (e.g., a 2:1 ratio of toluene to water).[9]
- Heat the mixture to 90-100 °C with vigorous stirring to ensure efficient mixing of the two phases.[9]
- Monitor the reaction progress by GC analysis of the organic layer. The reaction is typically complete within 2-4 hours.[9]
- Once the reaction is complete, cool the mixture to room temperature and transfer it to a separatory funnel.
- Separate the organic and aqueous layers.
- Wash the organic layer with water and then with brine.[9]
- Dry the organic layer over anhydrous magnesium sulfate, filter, and concentrate using a rotary evaporator to obtain 1-cyanoctane.[9]

## Applications in Electrochemistry

The inherent ionic conductivity and wide electrochemical window of quaternary ammonium salts make them promising electrolytes for various electrochemical devices, including batteries and dye-sensitized solar cells (DSSCs).[11][12]

## Methyltributylammonium Iodide as an Electrolyte in Zinc-Iodine Batteries

Recent research has shown that quaternary ammonium-based ionic liquids can be used as additives in the electrolyte of zinc-iodine batteries to suppress the growth of zinc dendrites and the shuttling of polyiodide ions, thereby improving the battery's cycle life.[11]

Conceptual Workflow for Battery Assembly and Testing:

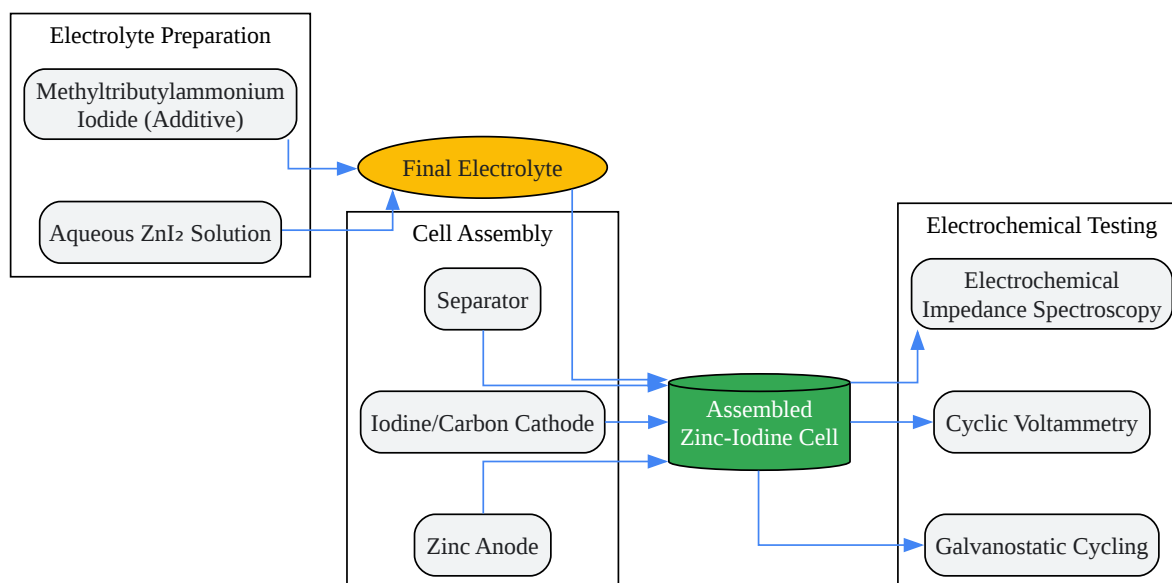

[Click to download full resolution via product page](#)

Caption: Conceptual workflow for using MTBAI in a zinc-iodine battery.

## Protocol: Preparation of an Ionic Liquid-Based Electrolyte for a DSSC

The iodide/triiodide redox couple is a standard component of electrolytes in dye-sensitized solar cells.[4] Ionic liquids like **methyltributylammonium iodide** can be used to create a less volatile and more stable electrolyte compared to traditional organic solvents.[13]

Materials:

- **Methyltributylammonium iodide** (MTBAI)
- Iodine ( $I_2$ )
- A suitable solvent if not using a pure ionic liquid electrolyte (e.g., acetonitrile or a low-viscosity ionic liquid)
- Components for DSSC fabrication (FTO glass,  $TiO_2$  paste, dye, platinum-coated counter electrode)

Procedure:

- Electrolyte Preparation:
  - In a light-protected vial, dissolve a specific concentration of **methyltributylammonium iodide** in the chosen solvent (or use it neat if its viscosity is low enough).
  - Add a smaller, optimized concentration of iodine to the solution. The iodine will react with the iodide ions to form the triiodide ( $I_3^-$ ) necessary for the redox shuttle. The ratio of  $I^-$  to  $I_2$  is a critical parameter for optimizing cell performance.
- DSSC Assembly:
  - Prepare the  $TiO_2$  photoanode on FTO glass and sensitize it with a suitable dye.
  - Assemble the DSSC in a sandwich configuration with the dye-sensitized photoanode, a spacer, and the platinum-coated counter electrode.

- Introduce the prepared electrolyte into the cell through pre-drilled holes in the counter electrode.
- Seal the cell to prevent leakage.
- Characterization:
  - Measure the photovoltaic performance of the assembled DSSC under simulated sunlight, including the open-circuit voltage ( $V_{oc}$ ), short-circuit current density ( $J_{sc}$ ), fill factor (FF), and power conversion efficiency (PCE).

## Conclusion

**Methyltributylammonium iodide** is a highly effective and versatile ionic liquid with significant potential in both academic research and industrial applications. Its utility as a phase-transfer catalyst is well-established, offering green and efficient alternatives to traditional synthetic methods. Furthermore, its emerging applications in electrochemical energy storage and conversion highlight its potential as a key component in next-generation technologies. The protocols and data presented in this guide are intended to provide a solid foundation for researchers to explore and exploit the full potential of this remarkable compound.

## References

- Spectrum and Reactivity of the Solvated Electron in the Ionic Liquid Methyltributylammonium Bis(trifluoromethylsulfonyl)imide. The Journal of Physical Chemistry B. [\[Link\]](#)
- methyl iodide - Organic Syntheses Procedure. Organic Syntheses. [\[Link\]](#)
- Viscosity and Ionic Conductivity of Imidazolium based Ionic Liquids bearing Triiodide Anion. E3S Web of Conferences. [\[Link\]](#)
- The Development of a Nucleophilic Substitution Reaction Experiment for the Organic Chemistry Laboratory. CUNY Academic Works. [\[Link\]](#)
- Revisiting applications of molecular iodine in organic synthesis. ResearchGate. [\[Link\]](#)
- Triethyl methyl ammonium ionic liquid as an effective electrolyte additive for high-performance zinc-iodine batteries. PubMed. [\[Link\]](#)

- Tributylmethylammonium chloride | C13H30N.Cl | CID 91822. PubChem. [\[Link\]](#)
- Viscosity and Ionic Conductivity of Imidazolium based Ionic Liquids bearing Triiodide Anion. ResearchGate. [\[Link\]](#)
- Phase-Transfer Catalysis (PTC). Macmillan Group. [\[Link\]](#)
- How do you synthesize Methyl ammonium iodide? ResearchGate. [\[Link\]](#)
- The Role of Methyl Iodide in Modern Organic Synthesis. Nanjing Kaimubo Pharmatech Company Limited. [\[Link\]](#)
- Ionic liquid/poly(ionic liquid)-based electrolytes for lithium batteries. Industrial Chemistry & Materials (RSC Publishing). [\[Link\]](#)
- Methyl Tributyl Ammonium Chloride – Aqueous. PTC Organics, Inc. [\[Link\]](#)
- Alkyl iodide synthesis by iodination or substitution. Organic Chemistry Portal. [\[Link\]](#)
- investigating viscosity and conductivity of ionic liquids. Institute For Research In Schools. [\[Link\]](#)
- ORGANIC CHEMISTRY CH 384, Fall 2009 WORKSHOP 8 Nucleophilic Substitution Reactions. University of Texas at Austin. [\[Link\]](#)
- Phase Transfer Catalysis. ACS Green Chemistry Institute Pharmaceutical Roundtable. [\[Link\]](#)
- Densities and Viscosities of Ionic Liquid with Organic Solvents. MDPI. [\[Link\]](#)
- Recent Progress in Synthetic Applications of Hypervalent Iodine(III) Reagents. PMC. [\[Link\]](#)
- 18 F-Fluorination Using Tri-Tert-Butanol Ammonium Iodide as Phase-Transfer Catalyst: An Alternative Minimalist Approach. MDPI. [\[Link\]](#)
- Density, viscosity and electrical conductivity of protic alkanolammonium ionic liquids. ScienceDirect. [\[Link\]](#)

- Electrolytes for Use in High Energy Lithium-Ion Batteries with Wide Operating Temperature Range. NASA. [[Link](#)]
- Dual Nature of the Excited State in Organic-Inorganic Lead Halide Perovskites - Supporting Information. ACS Publications. [[Link](#)]
- Study of nucleophilic aromatic substitution with diaryliodonium salts. Diva-Portal.org. [[Link](#)]
- Synthesis of [<sup>11</sup>C]methyl magnesium iodide and its application to the introduction of [<sup>11</sup>C]-N-tert-butyl groups and [<sup>11</sup>C]-sec-alcohols. University of Groningen research portal. [[Link](#)]
- Impact of tetrabutylammonium, iodide and triiodide ions conductivity in polyacrylonitrile based electrolyte on DSSC performance. ResearchGate. [[Link](#)]
- Methyltributylammonium Chloride | CAS# 56375-79-2. SACHEM, Inc.[[Link](#)]
- Properties and Applications of Ionic Liquids. Journal of Chemical Reviews. [[Link](#)]
- Phase-Transfer-Catalyzed Alkylation of Hydantoins. PMC. [[Link](#)]
- Safety Data Sheet. Greatcell Solar Materials. [[Link](#)]

### *Need Custom Synthesis?*

*BenchChem offers custom synthesis for rare earth carbides and specific isotopic labeling.*

*Email: [info@benchchem.com](mailto:info@benchchem.com) or [Request Quote Online](#).*

## Sources

- 1. Tributylmethylammonium chloride | C<sub>13</sub>H<sub>30</sub>N.Cl | CID 91822 - PubChem [[pubchem.ncbi.nlm.nih.gov](https://pubchem.ncbi.nlm.nih.gov)]
- 2. Methyl tributyl ammonium chloride | 56375-79-2 [[chemicalbook.com](https://chemicalbook.com)]
- 3. 18F-Fluorination Using Tri-Tert-Butanol Ammonium Iodide as Phase-Transfer Catalyst: An Alternative Minimalist Approach [[mdpi.com](https://mdpi.com)]
- 4. [e3s-conferences.org](https://e3s-conferences.org) [[e3s-conferences.org](https://e3s-conferences.org)]
- 5. [pubs.acs.org](https://pubs.acs.org) [[pubs.acs.org](https://pubs.acs.org)]

- [6. aksci.com \[aksci.com\]](#)
- [7. pdf.benchchem.com \[pdf.benchchem.com\]](#)
- [8. nbinno.com \[nbinno.com\]](#)
- [9. pdf.benchchem.com \[pdf.benchchem.com\]](#)
- [10. macmillan.princeton.edu \[macmillan.princeton.edu\]](#)
- [11. Triethyl methyl ammonium ionic liquid as an effective electrolyte additive for high-performance zinc-iodine batteries - PubMed \[pubmed.ncbi.nlm.nih.gov\]](#)
- [12. researchgate.net \[researchgate.net\]](#)
- [13. researchgate.net \[researchgate.net\]](#)
- To cite this document: BenchChem. [Methyltributylammonium Iodide: A Comprehensive Guide for Researchers and Drug Development Professionals]. BenchChem, [2026]. [Online PDF]. Available at:  
[\[https://www.benchchem.com/product/b1199620/docs#methyltributylammonium-iodide-a-comprehensive-guide-for-researchers-and-drug-development-professionals\]](https://www.benchchem.com/product/b1199620/docs#methyltributylammonium-iodide-a-comprehensive-guide-for-researchers-and-drug-development-professionals)

---

#### Disclaimer & Data Validity:

The information provided in this document is for Research Use Only (RUO) and is strictly not intended for diagnostic or therapeutic procedures. While BenchChem strives to provide accurate protocols, we make no warranties, express or implied, regarding the fitness of this product for every specific experimental setup.

**Technical Support:** The protocols provided are for reference purposes. Unsure if this reagent suits your experiment?

**Need Industrial/Bulk Grade?** [Request Custom Synthesis Quote](#)

## BenchChem

Our mission is to be the trusted global source of essential and advanced chemicals, empowering scientists and researchers to drive progress in science and industry.

#### Contact

Address: 3281 E Guasti Rd  
Ontario, CA 91761, United States  
Phone: (601) 213-4426  
Email: [info@benchchem.com](mailto:info@benchchem.com)

Contact our Ph.D. Support Team for a compatibility check