

# Application Note: High-Performance Liquid Chromatography for the Analysis of **Cibalgin**

**Author:** BenchChem Technical Support Team. **Date:** December 2025

## Compound of Interest

Compound Name: *Cibalgin*

Cat. No.: *B1197522*

[Get Quote](#)

## Introduction

**Cibalgin** is a combination analgesic drug formulation historically containing active ingredients such as aminophenazone and allobarbital. Aminophenazone, a pyrazolone derivative, possesses analgesic, anti-inflammatory, and antipyretic properties. Allobarbital is a barbiturate that acts as a central nervous system depressant, providing sedative effects. The quantitative analysis of these active pharmaceutical ingredients (APIs) in finished products is crucial for quality control, ensuring product safety and efficacy. High-Performance Liquid Chromatography (HPLC) is an ideal technique for this purpose, offering high resolution, sensitivity, and specificity for the simultaneous determination of multiple components in a single analytical run.

This application note details a stability-indicating reversed-phase HPLC (RP-HPLC) method for the simultaneous quantification of aminophenazone and allobarbital in pharmaceutical formulations.

## Principle of the Method

The method employs a reversed-phase C18 column with an isocratic mobile phase consisting of a buffered aqueous solution and an organic modifier. The separation is based on the differential partitioning of the analytes between the stationary phase and the mobile phase. Detection is achieved using a UV detector at a wavelength where both compounds exhibit significant absorbance. The method is designed to be stability-indicating, meaning it can resolve the active ingredients from their potential degradation products.

## Experimental

### Instrumentation and Chromatographic Conditions

A standard HPLC system equipped with a pump, autosampler, column oven, and a UV-Vis detector is suitable for this analysis. The specific conditions are outlined in the table below.

Parameter	Condition
HPLC System	Any standard HPLC system with a UV detector
Column	C18, 250 mm x 4.6 mm, 5 µm particle size
Mobile Phase	Phosphate buffer (pH 2.5) : Acetonitrile : Methanol (70:20:10, v/v/v)
Flow Rate	1.5 mL/min
Column Temperature	Ambient (~25 °C)
Detection Wavelength	230 nm
Injection Volume	20 µL
Run Time	Approximately 15 minutes

## Quantitative Data Summary

The following tables summarize the expected quantitative performance of the HPLC method for the analysis of aminophenazone and allobarbital. These values are based on typical performance for similar compounds and methods.[\[1\]](#)[\[2\]](#)

### System Suitability

Parameter	Aminophenazone	Allobarbital	Acceptance Criteria
Retention Time (min)	~4.5	~8.0	RSD ≤ 2%
Tailing Factor	< 1.5	< 1.5	≤ 2.0
Theoretical Plates	> 2000	> 2000	> 2000

## Method Validation Parameters

Parameter	Aminophenazone	Allobarbital
Linearity Range ( $\mu\text{g/mL}$ )	10 - 100	10 - 100
Correlation Coefficient ( $r^2$ )	> 0.999	> 0.999
Limit of Detection (LOD) ( $\mu\text{g/mL}$ )	~0.5	~0.5
Limit of Quantification (LOQ) ( $\mu\text{g/mL}$ )	~1.5	~1.5
Accuracy (% Recovery)	98 - 102	98 - 102
Precision (% RSD)	< 2.0	< 2.0

## Signaling Pathways of Active Ingredients

The following diagrams illustrate the simplified mechanisms of action for aminophenazone and allobarbital.

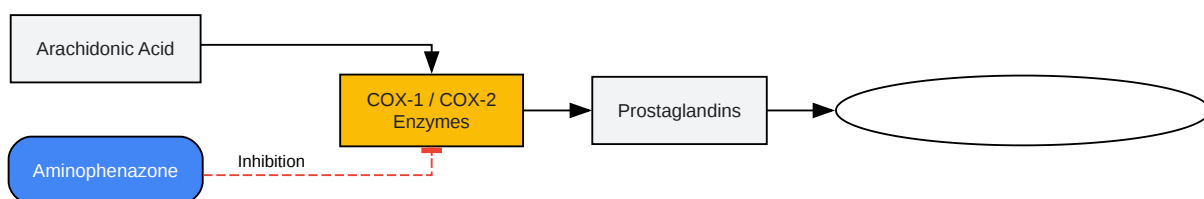

[Click to download full resolution via product page](#)

### Mechanism of Action of Aminophenazone

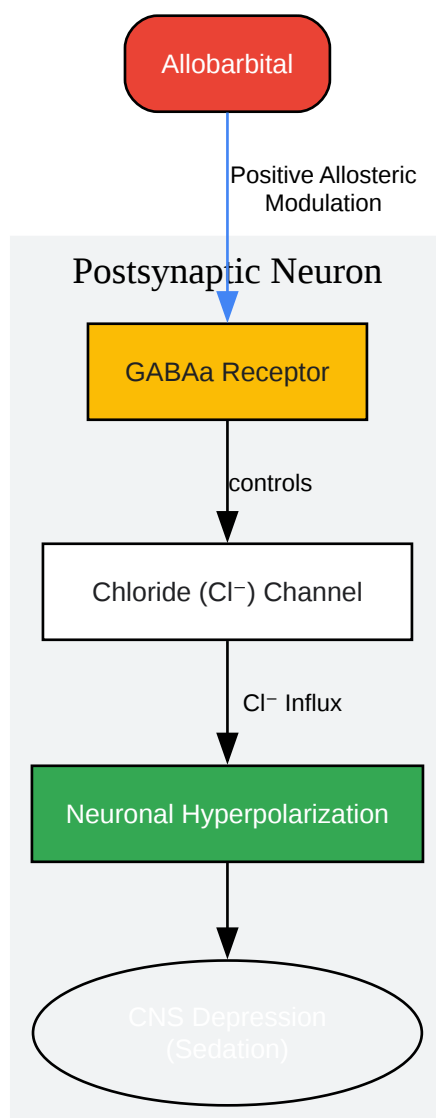

[Click to download full resolution via product page](#)

Mechanism of Action of Allobarbital

## Protocol: HPLC Analysis of Cibalgin Formulation Scope

This protocol describes the procedure for the quantitative determination of aminophenazone and allobarbital in a pharmaceutical formulation using RP-HPLC with UV detection.

## Materials and Reagents

- Aminophenazone reference standard
- Allobarbitol reference standard
- Acetonitrile (HPLC grade)
- Methanol (HPLC grade)
- Potassium dihydrogen phosphate (analytical grade)
- Orthophosphoric acid (analytical grade)
- Deionized water (18.2 MΩ·cm)
- Sample of **Cibalgin** tablets

## Preparation of Solutions

### 3.1. Mobile Phase Preparation (Phosphate buffer pH 2.5 : Acetonitrile : Methanol in 70:20:10 v/v/v)

- Dissolve an appropriate amount of potassium dihydrogen phosphate in deionized water to make a 0.025 M solution.
- Adjust the pH of the buffer solution to 2.5 with orthophosphoric acid.
- Filter the buffer through a 0.45 μm membrane filter.
- Mix the filtered buffer, acetonitrile, and methanol in the ratio of 70:20:10.
- Degas the mobile phase using sonication or vacuum filtration before use.

### 3.2. Standard Stock Solution Preparation (100 μg/mL)

- Accurately weigh about 10 mg of aminophenazone and 10 mg of allobarbitol reference standards.
- Transfer each standard into separate 100 mL volumetric flasks.

- Dissolve and dilute to volume with the mobile phase.
- This will give stock solutions with a concentration of 100 µg/mL for each analyte.

### 3.3. Working Standard Solution Preparation

- Prepare a series of working standard solutions by diluting the stock solutions with the mobile phase to cover the linearity range (e.g., 10, 25, 50, 75, and 100 µg/mL).

### 3.4. Sample Preparation

- Weigh and finely powder not fewer than 20 tablets of **Cibalgin**.
- Accurately weigh a portion of the powder equivalent to the average tablet weight.
- Transfer the powder to a 100 mL volumetric flask.
- Add approximately 70 mL of the mobile phase and sonicate for 15 minutes to dissolve the active ingredients.
- Dilute to volume with the mobile phase and mix well.
- Filter the solution through a 0.45 µm syringe filter into an HPLC vial.

## HPLC Analysis Workflow

The general workflow for the HPLC analysis is depicted in the diagram below.

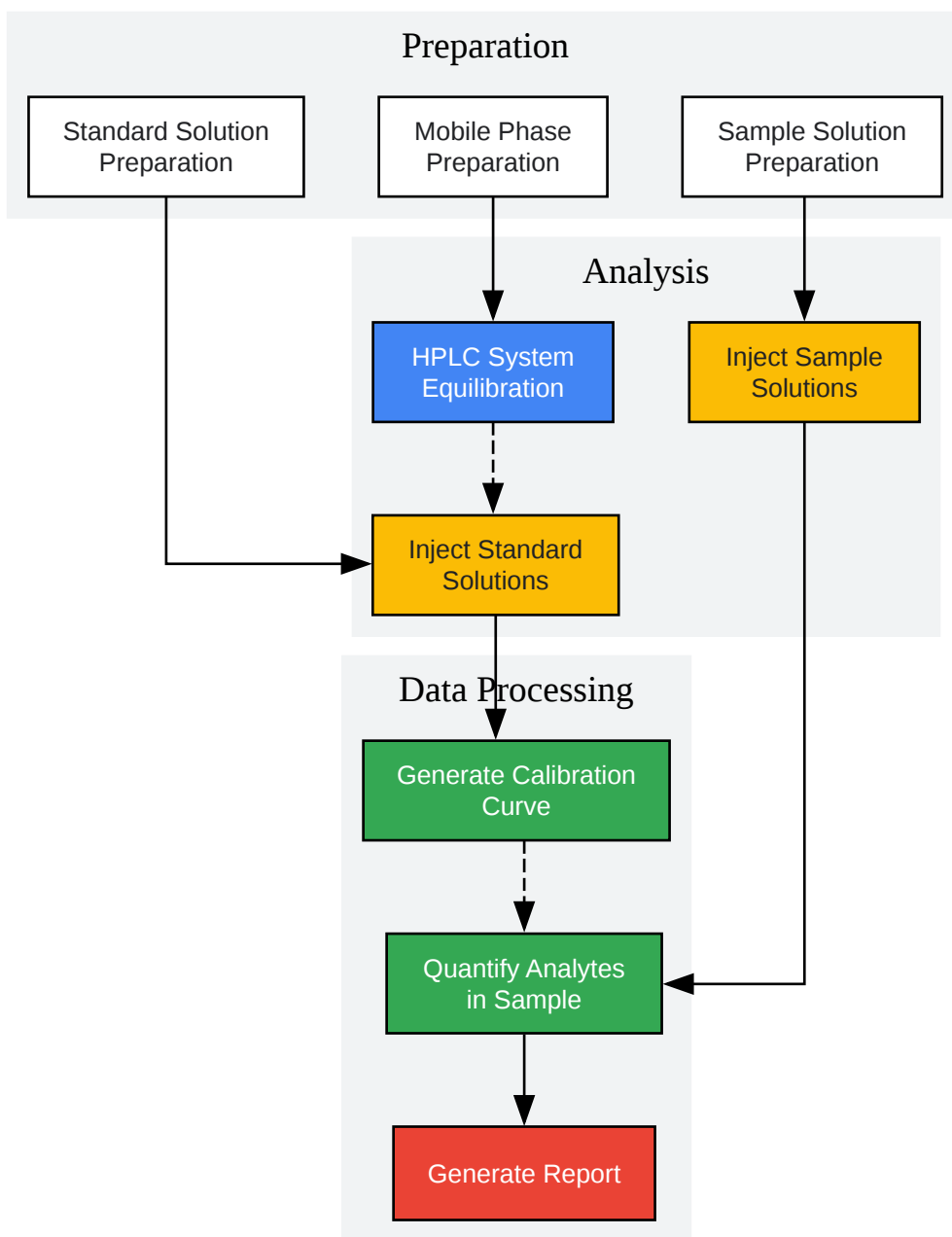

[Click to download full resolution via product page](#)

## HPLC Experimental Workflow

### Procedure

- Equilibrate the HPLC system with the mobile phase for at least 30 minutes or until a stable baseline is achieved.

- Perform a blank injection (mobile phase) to ensure no interfering peaks are present.
- Inject the standard solutions in triplicate to establish the calibration curve and check for system suitability.
- Inject the sample solutions in triplicate.
- After all analyses are complete, flush the column with a suitable solvent mixture (e.g., methanol/water) and store it according to the manufacturer's recommendations.

## Data Analysis and Calculations

- Identify the peaks for aminophenazone and allobarbital in the chromatograms based on their retention times from the standard injections.
- For each standard solution, determine the peak area for each analyte.
- Construct a calibration curve by plotting the peak area versus the concentration for each analyte. Perform a linear regression analysis to obtain the equation of the line ( $y = mx + c$ ) and the correlation coefficient ( $r^2$ ).
- Determine the peak area of each analyte in the sample chromatograms.
- Calculate the concentration of each analyte in the sample solution using the regression equation from the calibration curve.
- Calculate the amount of each active ingredient per tablet using the following formula:

$$\text{Amount per tablet (mg)} = (C \times V \times D) / L$$

Where:

- C = Concentration of the analyte in the sample solution (mg/mL)
- V = Volume of the volumetric flask used for sample preparation (mL)
- D = Average tablet weight (mg)
- L = Weight of the powdered sample taken for analysis (mg)



## Conclusion

The described RP-HPLC method is simple, accurate, and precise for the simultaneous determination of aminophenazone and allobarbital in pharmaceutical dosage forms. The method can be used for routine quality control analysis and for stability studies of **Cibalgin** and similar formulations.

## References

- 1. Validated stability indicating RP-HPLC method for the determination of phenazone and lidocaine hydrochloride in bulk and dosage form - Int J Pharm Chem Anal [ijpca.org]
- 2. Stability-Indicating Assay for the Determination of Pentobarbital Sodium in Liquid Formulations - PMC [pmc.ncbi.nlm.nih.gov]
- To cite this document: BenchChem. [Application Note: High-Performance Liquid Chromatography for the Analysis of Cibalgin]. BenchChem, [2025]. [Online PDF]. Available at: [<https://www.benchchem.com/product/b1197522#high-performance-liquid-chromatography-methods-for-cibalgin-analysis>]

---

### Disclaimer & Data Validity:

The information provided in this document is for Research Use Only (RUO) and is strictly not intended for diagnostic or therapeutic procedures. While BenchChem strives to provide accurate protocols, we make no warranties, express or implied, regarding the fitness of this product for every specific experimental setup.

**Technical Support:** The protocols provided are for reference purposes. Unsure if this reagent suits your experiment? [[Contact our Ph.D. Support Team for a compatibility check](#)]

**Need Industrial/Bulk Grade?** [Request Custom Synthesis Quote](#)

# BenchChem

Our mission is to be the trusted global source of essential and advanced chemicals, empowering scientists and researchers to drive progress in science and industry.

## Contact

Address: 3281 E Guasti Rd

Ontario, CA 91761, United States

Phone: (601) 213-4426

Email: [info@benchchem.com](mailto:info@benchchem.com)