

Application Note: Octadecylboronic Acid (ODBA) in Fluorescent Biosensors

Author: BenchChem Technical Support Team. **Date:** May 2026

Compound of Interest

Compound Name: Octadecylboronic acid

CAS No.: 4445-09-4

Cat. No.: B1196986

[Get Quote](#)

Executive Summary

This guide details the application of **Octadecylboronic Acid (ODBA)** and its derivatives (e.g., 4-octadecylphenylboronic acid) in the design of fluorescent biosensors. Unlike water-soluble boronic acids used in solution-phase sensing, ODBA is defined by its C18 hydrophobic tail. This structural feature enables the formation of supramolecular assemblies (vesicles, micelles) or the functionalization of lipid bilayers (liposomes, cell membranes).

This document focuses on the Indicator Displacement Assay (IDA), utilizing Alizarin Red S (ARS) as the optical reporter.[1] This system provides a robust, non-enzymatic method for detecting glucose, fructose, and cell-surface sialic acids.

Introduction: The Amphiphilic Advantage

Boronic acids are Lewis acids that reversibly form cyclic esters with cis-1,2- or cis-1,3-diols (found in sugars).[2] While phenylboronic acid (PBA) is the standard recognition motif, it lacks intrinsic structural organization.

Octadecylboronic Acid (ODBA) incorporates a stearyl (C18) chain, transforming the recognition unit into an amphiphile.

- **Hydrophobic Tail (C18):** Drives self-assembly into vesicles or insertion into existing lipid bilayers (anchoring).
- **Hydrophilic Head (Boronic Acid):** Remains at the aqueous interface, available for binding sugars.

This dual nature allows for the creation of "Boronic Acid Liposomes," which mimic cellular recognition surfaces and offer higher sensitivity due to the multivalent presentation of binding sites on the vesicle surface.

Mechanism of Action: The ARS Displacement Assay

Since ODBA is non-fluorescent, it is paired with Alizarin Red S (ARS), a catecholic fluorophore. The sensing mechanism relies on competitive binding.

- **Assembly:** ODBA is anchored in a lipid membrane (liposome).
- **Quenching/Binding:** ARS binds to the boronic acid headgroup of ODBA, forming a cyclic boronate ester. This complexation alters the excitation/emission profile of ARS (typically quenching fluorescence or shifting absorbance).
- **Detection (Signal Recovery):** When a target sugar (e.g., Glucose) is introduced, it competes for the boronic acid. Since glucose often has a higher affinity (or concentration dominance), it displaces the ARS.
- **Result:** Free ARS is released into the bulk solution, recovering its original fluorescence.

Pathway Diagram: ARS Displacement on Liposomes

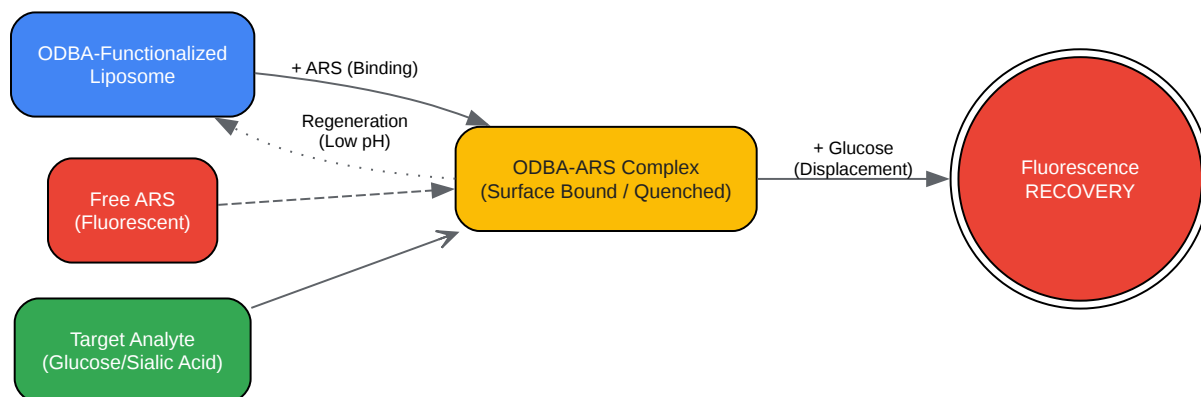

[Click to download full resolution via product page](#)

Figure 1: The Indicator Displacement Assay (IDA) mechanism. ARS binds to the membrane-anchored ODBA, quenching fluorescence. Glucose displaces ARS, restoring the signal.

Protocol A: Synthesis of ODBA-Functionalized Liposomes

This protocol describes the co-assembly of ODBA with standard lipids (DOPC) to create sensor vesicles.

Materials Required^{[2][3][4][5][6][7][8][9][10]}

- Lipid: 1,2-Dioleoyl-sn-glycero-3-phosphocholine (DOPC).
- Sensor: 4-Octadecylphenylboronic acid (ODBA-PBA) or **Octadecylboronic acid**.
- Solvents: Chloroform (HPLC grade), Methanol.
- Buffer: 10 mM Carbonate Buffer, pH 9.0 (High pH is required for optimal Boronic Acid-Diol binding unless using specialized derivatives).

Step-by-Step Workflow

- Stock Preparation:

- Dissolve DOPC in Chloroform (10 mg/mL).
- Dissolve ODBA in Chloroform/Methanol (9:1 v/v) (1 mg/mL).
- Film Formation:
 - Mix DOPC and ODBA in a molar ratio of 95:5 (Lipid:Sensor) in a round-bottom flask.
 - Evaporate solvents under a nitrogen stream to form a thin, uniform lipid film.
 - Vacuum dry for >4 hours to remove residual solvent.
- Hydration:
 - Add Carbonate Buffer (pH 9.0) to the flask to achieve a final lipid concentration of 1 mM.
 - Vortex vigorously for 30 minutes at room temperature. This forms Multilamellar Vesicles (MLVs).
- Extrusion (Sizing):
 - Pass the MLV suspension through a polycarbonate membrane (100 nm pore size) 11-21 times using a mini-extruder.
 - Result: Large Unilamellar Vesicles (LUVs) with ODBA displaying the boronic acid headgroup on the surface.

Workflow Diagram: Liposome Fabrication

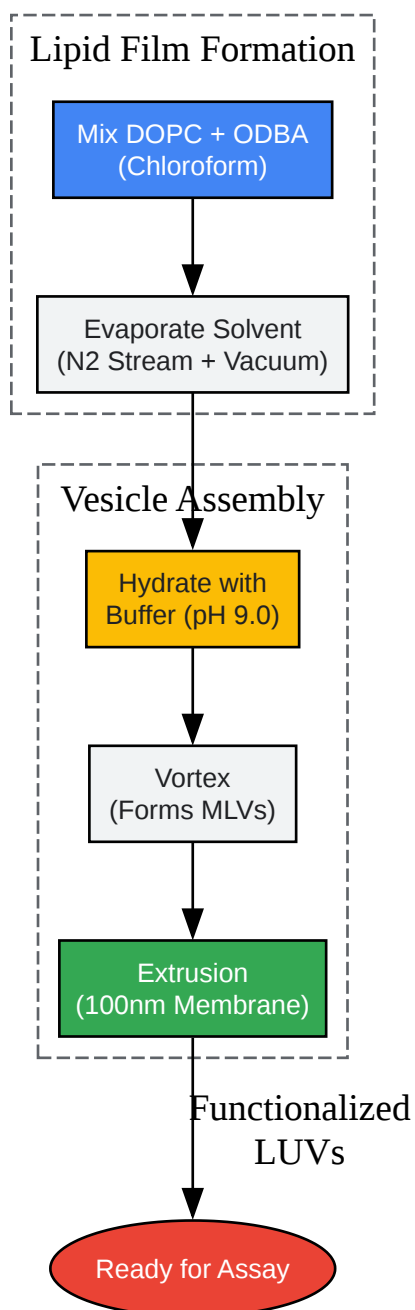

[Click to download full resolution via product page](#)

Figure 2: Workflow for preparing ODBA-functionalized Large Unilamellar Vesicles (LUVs).

Protocol B: Fluorescent Sensing Assay

Experimental Setup

- Excitation/Emission (ARS): Ex: 460 nm / Em: 570 nm (Note: Spectra shift upon binding; verify peak max for your specific buffer).
- Temperature: 25°C.

Procedure

- Baseline (F0): Take 1 mL of ODBA-Liposome suspension. Measure fluorescence.[1][2][3][4][5][6][7][8][9][10][11][12] (Should be low/background).
- Reporter Loading: Add Alizarin Red S (ARS) to a final concentration of 10 μ M. Incubate for 10 minutes.
 - Observation: Fluorescence should change (typically quench or shift) as ARS binds to the liposome surface.
- Titration: Add aliquots of the target sugar solution (Glucose or Fructose).
- Measurement: Record fluorescence intensity after each addition (allow 2 mins for equilibrium).
- Data Analysis: Plot
against sugar concentration.

Comparative Binding Data (Typical Trends)

Analyte	Binding Affinity ()	Detection Limit	Specificity Note
D-Fructose	High (~4000)	~0.1 mM	Forms stable tridentate complex.
D-Glucose	Moderate (~100-200)	~1-5 mM	Physiologically relevant range.
Galactose	Low	>10 mM	Weak interference.

Note: Boronic acids generally bind Fructose stronger than Glucose. To improve Glucose selectivity, bis-boronic acid scaffolds or specific buffer formulations are often required.

Application Note: Cell Surface Glycan Detection

Beyond simple glucose sensing, ODBA is a powerful tool for cell surface engineering.

Mechanism: The hydrophobic C18 tail of ODBA spontaneously inserts into the plasma membrane of live cells. The boronic acid headgroup is then displayed extracellularly.

- Usage: This allows the "painting" of cell surfaces with boronic acids to detect sialic acid-rich glycoproteins or to facilitate drug delivery vehicles (boronic acid liposomes) binding to tumor cells (which often overexpress sialic acid).

Protocol Modification: Instead of forming liposomes, dissolve ODBA in DMSO (stock). Add to cell culture media (<1% DMSO final). Incubate cells for 30 mins. Wash. The cells are now functionalized. Add ARS to visualize surface glycan competition or use the boronic acid to capture sialic-acid-capped nanoparticles.

Troubleshooting & Optimization (Expert Insights)

- pH Sensitivity (The pKa Problem):
 - Issue: Standard boronic acids have a pKa ~8.8. They only bind diols effectively when in the tetrahedral anionic form ($\text{pH} > \text{pKa}$).
 - Solution: Perform assays at pH 9.0 (Carbonate buffer). For physiological pH (7.4) sensing, use 3-pyridyl derivatives or introduce a cationic lipid (like DOTAP) into the liposome to stabilize the anionic boronate via electrostatic attraction.
- Aggregation:
 - Issue: ODBA is highly hydrophobic. If not properly mixed with lipids, it precipitates.
 - Solution: Always co-dissolve in organic solvent before hydration. Do not add ODBA directly to water.
- Fructose Interference:

- Issue: Fructose binds tighter than glucose.[4]
- Solution: If measuring blood glucose, this is less critical as glucose concentration (mM) is much higher than fructose (M). For food analysis, use a dual-sensor array to discriminate.

References

- Foundational Review: Bull, S. D., Davidson, M. G., van den Elsen, J. M., Fossey, J. S., Jenkins, A. T., Jiang, Y. B., ... & James, T. D. (2013). "Boronic acid-based sensors for the detection of saccharides." *Accounts of Chemical Research*. [Link](#)
- ARS Mechanism: Springsteen, G., & Wang, B. (2002). "A detailed examination of boronic acid-diol complexation." *Tetrahedron*. [Link](#)
- Amphiphilic Assemblies: Ivanov, A. E., et al. (2025/Recent). "Functionalized Vesicles Based on Amphiphilic Boronic Acids: A System for Recognizing Biologically Important Polyols." *ResearchGate/Journal of Liposome Research*. [Link](#)
- Liposome Delivery: Zhang, X., et al. (2014). "Boronic Acid Liposomes for Cellular Delivery and Content Release Driven by Carbohydrate Binding." [8] *Bioconjugate Chemistry*. [Link](#)
- Membrane Anchoring: Boonyarattanakalin, S., et al. (2004). "Chemical Scale for Evaluating the Stability of Boronate-Based Carbohydrate Sensors." *J. Am. Chem. Soc.* [Link](#)

Need Custom Synthesis?

BenchChem offers custom synthesis for rare earth carbides and specific isotopic labeling.

Email: info@benchchem.com or [Request Quote Online](#).

Sources

- [1. researchgate.net](https://www.researchgate.net) [[researchgate.net](https://www.researchgate.net)]
- [2. Recent development of boronic acid-based fluorescent sensors - RSC Advances \(RSC Publishing\)](https://pubs.rsc.org) [pubs.rsc.org]

- [3. researchgate.net \[researchgate.net\]](#)
- [4. Recent Advances in Fluorescent Arylboronic Acids for Glucose Sensing - PMC \[pmc.ncbi.nlm.nih.gov\]](#)
- [5. mdpi.com \[mdpi.com\]](#)
- [6. Progress in boronic acid-based fluorescent glucose sensors - PubMed \[pubmed.ncbi.nlm.nih.gov\]](#)
- [7. mdpi.com \[mdpi.com\]](#)
- [8. Boronic Acid Liposomes for Cellular Delivery and Content Release Driven by Carbohydrate Binding - PMC \[pmc.ncbi.nlm.nih.gov\]](#)
- [9. Boronic acids for sensing and other applications - a mini-review of papers published in 2013 - PMC \[pmc.ncbi.nlm.nih.gov\]](#)
- [10. mdpi.com \[mdpi.com\]](#)
- [11. researchgate.net \[researchgate.net\]](#)
- [12. pubs.acs.org \[pubs.acs.org\]](#)
- To cite this document: BenchChem. [Application Note: Octadecylboronic Acid (ODBA) in Fluorescent Biosensors]. BenchChem, [2026]. [Online PDF]. Available at: [<https://www.benchchem.com/product/b1196986/docs#application-note-octadecylboronic-acid-odba-in-fluorescent-biosensors>]

Disclaimer & Data Validity:

The information provided in this document is for Research Use Only (RUO) and is strictly not intended for diagnostic or therapeutic procedures. While BenchChem strives to provide accurate protocols, we make no warranties, express or implied, regarding the fitness of this product for every specific experimental setup.

Technical Support: The protocols provided are for reference purposes. Unsure if this reagent suits your experiment?

Need Industrial/Bulk Grade? [Request Custom Synthesis Quote](#)

BenchChem

Our mission is to be the trusted global source of essential and advanced chemicals, empowering scientists and researchers to drive progress in science and industry.

Contact

Address: 3281 E Guasti Rd
Ontario, CA 91761, United States
Phone: (601) 213-4426
Email: info@benchchem.com

[Contact our Ph.D. Support Team for a compatibility check](#)