

# Technical Support Center: Optimizing Reaction Conditions for Product Purity

**Author:** BenchChem Technical Support Team. **Date:** April 2026

## Compound of Interest

Compound Name: (4-chlorophenyl) 4-nitrobenzenesulfonate

CAS No.: 128886-84-0

Cat. No.: B11957818

[Get Quote](#)

A Guide for Researchers, Scientists, and Drug Development Professionals

Welcome to the Technical Support Center. As a Senior Application Scientist, I've designed this guide to provide you with in-depth, field-proven insights into one of the most critical aspects of chemical synthesis: the impact of reaction conditions on product purity. This resource moves beyond simple step-by-step instructions to explain the why behind experimental choices, empowering you to troubleshoot effectively and optimize your reactions for the highest possible purity.

## Frequently Asked Questions (FAQs)

Here, we address some of the most common questions encountered during chemical synthesis and drug development related to reaction temperature and time.

### Q1: Why is my product purity low despite the reaction going to completion?

A: Low purity, even with complete consumption of starting materials, often points to the formation of side products or degradation of the desired product. Several factors related to temperature and time can contribute to this:

- Side Reactions: Elevated temperatures can provide the necessary activation energy for alternative reaction pathways, leading to the formation of undesired byproducts.[1]
- Product Degradation: The desired product, once formed, may not be stable under the reaction conditions. Prolonged reaction times or excessive temperatures can lead to its decomposition.[1][2] Many pharmaceutical products are temperature-sensitive, and exposure to non-optimal temperatures can cause molecular breakdown, rendering them ineffective or even harmful.[2][3][4]
- Kinetic vs. Thermodynamic Control: Sometimes, a less stable "kinetic" product forms faster at lower temperatures, while a more stable "thermodynamic" product is favored at higher temperatures and longer reaction times.[5][6][7] If your desired product is the kinetic one, extended reaction times or higher temperatures might be converting it to the thermodynamic, undesired product.

Troubleshooting Steps:

- Monitor the reaction over time: Use techniques like Thin-Layer Chromatography (TLC) or High-Performance Liquid Chromatography (HPLC) to track the appearance and disappearance of both the product and impurities throughout the reaction.[8][9][10] This can help you identify the optimal time to quench the reaction before significant degradation or side product formation occurs.[11]
- Perform a temperature study: Run the reaction at a range of temperatures to determine the optimal balance between reaction rate and impurity formation.[12][13][14]
- Consider a different workup procedure: Impurities may be introduced or formed during the workup and purification steps. Ensure your purification methods are suitable for separating the desired product from the specific impurities present.

**Q2: I'm observing the formation of multiple products. How can I improve the selectivity for my desired**

## compound?

A: The formation of multiple products, such as isomers, is a common challenge where temperature and time play a crucial role in controlling selectivity.

- **Regioselectivity and Stereoselectivity:** Temperature can significantly influence the regioselectivity (where on a molecule a reaction occurs) and stereoselectivity (the spatial arrangement of the resulting molecule) of a reaction.<sup>[15][16][17]</sup> In some cases, lower temperatures favor the formation of one isomer, while higher temperatures favor another.<sup>[17][18]</sup>
- **Kinetic vs. Thermodynamic Control:** As mentioned previously, the product distribution can be governed by whether the reaction is under kinetic or thermodynamic control.<sup>[5][6][7]</sup> Short reaction times and lower temperatures favor the kinetic product, which is formed fastest. Longer reaction times and higher temperatures allow the system to reach equilibrium, favoring the most stable thermodynamic product.<sup>[5][6]</sup>

Troubleshooting and Optimization Strategies:

- **Temperature Screening:** Systematically vary the reaction temperature to find the optimal point for the formation of the desired isomer. Even small changes in temperature can have a significant impact on selectivity.<sup>[19]</sup>
- **Time Course Analysis:** Monitor the product distribution at different time points to understand the kinetics of isomer formation.
- **Solvent Effects:** The choice of solvent can also influence selectivity in conjunction with temperature.<sup>[18]</sup> Consider screening different solvents.

## Q3: My reaction is very slow at low temperatures, but at higher temperatures, I get a lot of impurities. What should I do?

A: This is a classic optimization problem. The goal is to find a temperature that is high enough to achieve a reasonable reaction rate but low enough to minimize the formation of impurities.<sup>[12]</sup>

### Strategies for Optimization:

- **Catalyst Optimization:** A more active catalyst can increase the reaction rate at lower temperatures, allowing you to avoid the high temperatures that lead to impurity formation.
- **Concentration Effects:** Increasing the concentration of reactants can sometimes increase the reaction rate without needing to raise the temperature. However, be cautious as this can also affect the rate of side reactions.
- **Design of Experiments (DoE):** DoE is a powerful statistical tool for systematically optimizing multiple reaction parameters simultaneously, including temperature, time, and reactant concentrations.<sup>[20][21][22][23][24][25]</sup> This approach is more efficient than the traditional one-factor-at-a-time (OFAT) method and can reveal interactions between variables.<sup>[21][23]</sup>

## Q4: How do I know the optimal reaction time?

A: The optimal reaction time is the point at which the concentration of your desired product is at its maximum, and the formation of degradation products is at a minimum.

### Methods for Determining Optimal Reaction Time:

- **Reaction Monitoring:** The most reliable way to determine the optimal reaction time is to monitor the reaction's progress.
  - **TLC:** A quick and easy method for qualitative analysis of the reaction mixture.<sup>[8][10]</sup>
  - **HPLC/UHPLC:** Provides quantitative data on the concentration of starting materials, products, and impurities over time.<sup>[9][26]</sup>
  - **In-situ Sampling:** Automated in-situ sampling tools can provide a detailed reaction profile by collecting samples at regular intervals for analysis.<sup>[11]</sup>
- **Time-Course Study:** Run the reaction and take samples at various time points (e.g., 1, 2, 4, 8, and 24 hours). Analyze these samples to create a concentration vs. time profile for your product and key impurities. A case study on amide synthesis showed that while product yield increased with time, purity was highest at shorter reaction times.<sup>[27]</sup>

## Troubleshooting Guide: Common Issues and Solutions

This section provides a more focused approach to troubleshooting specific problems you might encounter.

Problem	Potential Cause (Temperature/Time Related)	Troubleshooting Steps
Low Product Yield	Incomplete reaction due to insufficient temperature or time. <a href="#">[1]</a>	- Increase reaction temperature in small increments. - Extend the reaction time and monitor for completion using TLC or HPLC. <a href="#">[1]</a>
Product degradation from excessive heat or prolonged reaction time. <a href="#">[1]</a>	- Lower the reaction temperature. - Perform a time-course study to find the optimal reaction time before significant degradation occurs.	
Presence of Unreacted Starting Material	Reaction time is too short. <a href="#">[1]</a>	- Increase the reaction time and monitor progress.
Reaction temperature is too low, resulting in a slow reaction rate. <a href="#">[1]</a>	- Gradually increase the reaction temperature while monitoring for the formation of impurities.	
Formation of a Dark, Tarry Substance	Reaction temperature was too high, leading to decomposition. <a href="#">[1]</a>	- Carefully control the reaction temperature, ensuring it does not exceed the recommended range. - Consider pre-cooling the reaction mixture for exothermic reactions before adding reagents. <a href="#">[28]</a>
Inconsistent Results Between Batches	Poor temperature control, leading to variations in reaction conditions.	- Use a reliable temperature control system like an oil bath, heating mantle, or a recirculating chiller. <a href="#">[28]</a> - Ensure consistent and efficient stirring to avoid hot spots, especially in exothermic reactions. <a href="#">[28]</a> <a href="#">[29]</a>

---

Runaway Exothermic Reaction	The rate of heat generation exceeds the rate of heat removal.[30][31]	- Immediate Action: Stop reagent addition and maximize cooling.[29] - Prevention: Use controlled, slow reagent addition (dosing).[29] Dilute the reaction mixture.[31] Ensure your cooling system is adequate for the scale of the reaction.
-----------------------------	---	--

---

## Experimental Protocols

### Protocol 1: Optimization of Reaction Temperature Using a Gradient Approach

This protocol outlines a systematic way to determine the optimal reaction temperature.

- Setup: Prepare multiple identical reactions in parallel. Use a reaction block or multiple reaction vessels in a temperature-controlled bath that allows for a temperature gradient.
- Temperature Range: Set a range of temperatures to be tested. For example, if the initial procedure calls for 60°C, you might test 40°C, 50°C, 60°C, 70°C, and 80°C.
- Execution: Start all reactions simultaneously and run them for the same amount of time.
- Analysis: Quench each reaction and analyze the crude product mixture by HPLC or another suitable analytical technique to determine the purity and yield at each temperature.
- Evaluation: Plot the product purity and yield as a function of temperature to identify the optimal temperature.

### Protocol 2: Determining Optimal Reaction Time via a Time-Course Study

This protocol helps to pinpoint the ideal reaction duration.

- Setup: Set up a single, larger-scale reaction at the optimized temperature.

- **Sampling:** At predetermined time intervals (e.g., 0.5, 1, 2, 4, 8, 12, and 24 hours), carefully withdraw a small, representative sample from the reaction mixture.
- **Quenching:** Immediately quench the reaction in each sample to stop any further transformation. This can be done by cooling it rapidly or adding a quenching agent.
- **Analysis:** Analyze each quenched sample by HPLC to quantify the concentration of the starting material, desired product, and any major impurities.
- **Data Plotting:** Plot the concentration of each species as a function of time. The optimal reaction time is typically where the product concentration is at its peak before it begins to decline due to degradation.

## Visualizing Key Concepts

### Kinetic vs. Thermodynamic Control

The following diagram illustrates the energy profile for a reaction that can form two different products: a kinetic product and a thermodynamic product.

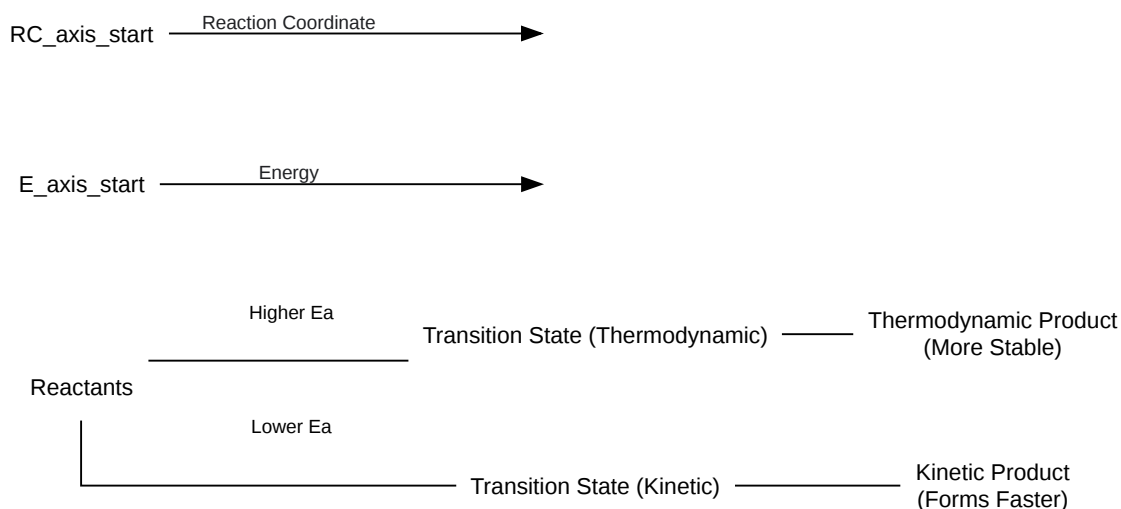

[Click to download full resolution via product page](#)

Caption: Energy profile of kinetic vs. thermodynamic products.

## Troubleshooting Workflow for Low Product Purity

This flowchart provides a logical sequence of steps to diagnose and resolve issues of low product purity.

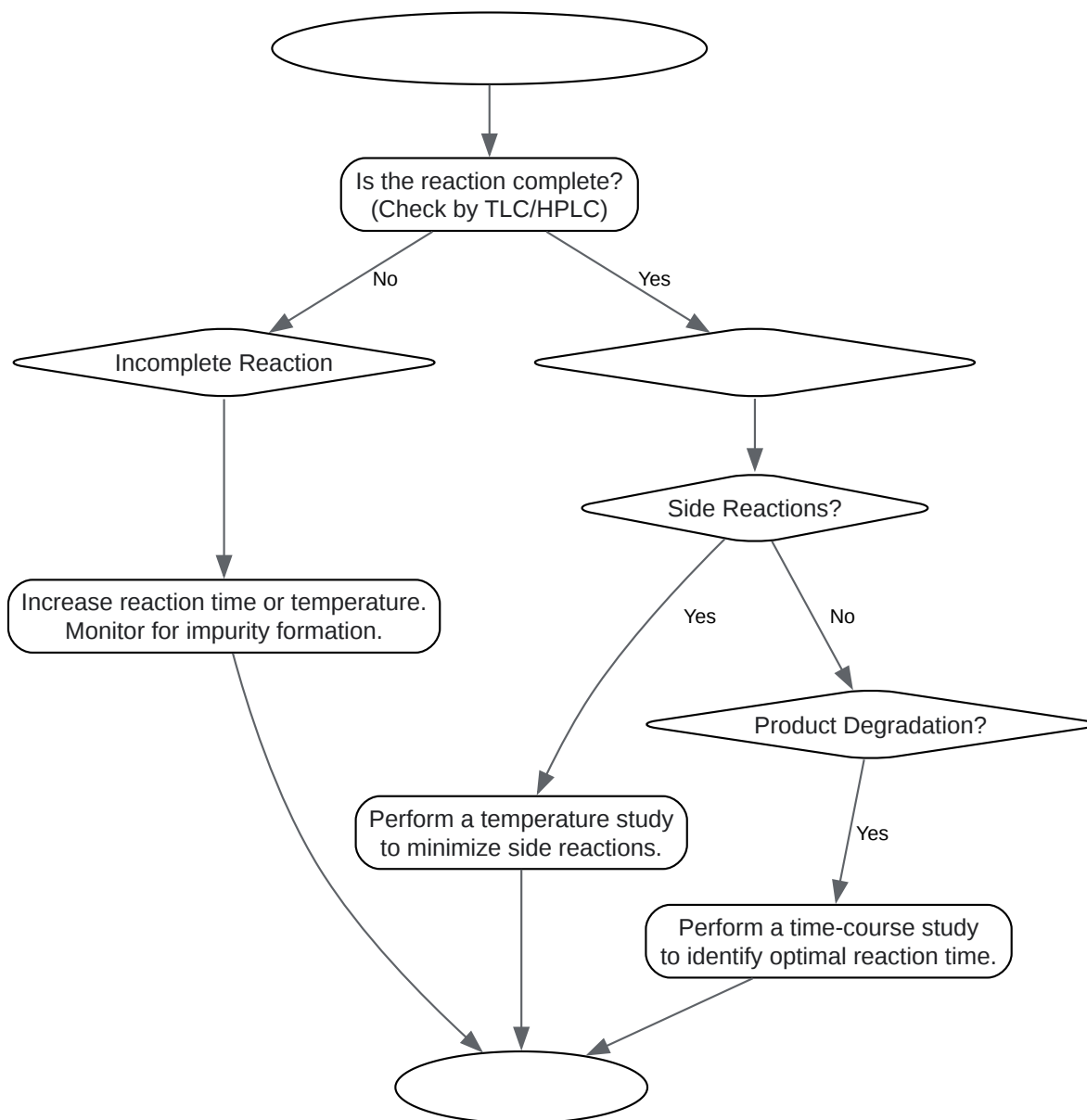

[Click to download full resolution via product page](#)

Caption: Troubleshooting workflow for low product purity.

## References

- Science Ready. (n.d.). Factors Considered When Designing a Chemical Synthesis Process. Retrieved from [[Link](#)]
- Lab Safety. (2025, December 25). Best Practices for Working with Chemical Reactions in the Lab. Retrieved from [[Link](#)]
- Homework.Study.com. (n.d.). How does temperature affect regiochemistry and stereochemistry? Retrieved from [[Link](#)]
- Patsnap. (2025, September 3). Control Strategies For Managing Exothermic Reactions In Flow. Retrieved from [[Link](#)]
- Wikipedia. (n.d.). Thermodynamic and kinetic reaction control. Retrieved from [[Link](#)]
- Roy, D. (n.d.). Effect of Temperature on the Purity and Yield of Aspirin. AWS. Retrieved from [[Link](#)]
- Roy, D. (n.d.). Effect of Temperature on the Purity and Yield of Aspirin. Academia.edu. Retrieved from [[Link](#)]
- SpotSee. (2024, March 11). Effects of Temperature Change on Biologic Drugs. Retrieved from [[Link](#)]
- Biotage. (2023, February 6). How does reaction time impact synthetic product purity and yield? Retrieved from [[Link](#)]
- ChemRxiv. (n.d.). Environmental Control of Regio-/Stereoselectivity Across Mechanistically Similar Transformations. Retrieved from [[Link](#)]
- Caister Academic Press. (2011, January 15). PCR Troubleshooting and Optimization: The Essential Guide. Retrieved from [[Link](#)]
- Minitab. (2025, August 21). Best Practices For Implementing Design Of Experiments (DOE) In Industrial Settings. Retrieved from [[Link](#)]
- ACS Axial. (2025, May 12). A Practical Start-Up Guide for Synthetic Chemists to Implement Design of Experiments (DoE). Retrieved from [[Link](#)]

- Triclinic Labs. (n.d.). Chromatographic Purity Analysis and Separation Sciences (TLC, HPLC, GC). Retrieved from [\[Link\]](#)
- Mettler Toledo. (n.d.). Design of Experiments (DoE) Studies. Retrieved from [\[Link\]](#)
- Organic Chemistry Portal. (2012). Solvent- or Temperature-Controlled Diastereoselective Aldol Reaction of Methyl Phenylacetate. Retrieved from [\[Link\]](#)
- PP Healthcare Solutions. (2023, February 27). Understanding the Temperature-Sensitive Nature of Drugs. Retrieved from [\[Link\]](#)
- PMC. (2022, June 16). Exploring the Temperature Effect on Enantioselectivity of a Baeyer-Villiger Biooxidation by the 2,5-DKCMO Module: The SLM Approach. Retrieved from [\[Link\]](#)
- Mettler Toledo. (n.d.). Impurity Profiling of Chemical Reactions | Process Development Strategies. Retrieved from [\[Link\]](#)
- Dalal Institute. (n.d.). Kinetic and Thermodynamic Control. Retrieved from [\[Link\]](#)
- Mercatus Bioscience. (2024, May 7). Impact of temperature fluctuation on medicines. Retrieved from [\[Link\]](#)
- Health Authority. (2023, September 7). Rising temperatures can cause serious side effects with many medicines. Retrieved from [\[Link\]](#)
- Master Organic Chemistry. (2012, February 9). Thermodynamic and Kinetic Products. Retrieved from [\[Link\]](#)
- Chemical Industry Journal. (2022, June 1). Handling Reaction Exotherms – A Continuous Approach. Retrieved from [\[Link\]](#)
- Jack Westin. (n.d.). Kinetic Control Versus Thermodynamic Control Of A Reaction - Rate Processes In Chemical Reactions Kinetics And Equilibrium - MCAT Content. Retrieved from [\[Link\]](#)
- Lab Manager. (2025, October 22). Using Design of Experiments (DoE) in Method Development. Retrieved from [\[Link\]](#)

- Walsh Medical Media. (n.d.). The Impact of Climate Change on Drug Safety and Efficacy. Retrieved from [[Link](#)]
- Statistical Software. (2026, January 27). Design of Experiments (DOE): A Comprehensive Guide to Experimental Planning and Analysis. Retrieved from [[Link](#)]
- ResearchGate. (n.d.). (PDF) TLC/HPTLC and HPLC methods for monitoring microbial transformation processes. Retrieved from [[Link](#)]
- Taylor & Francis. (n.d.). Regioselectivity – Knowledge and References. Retrieved from [[Link](#)]
- Lab Manager. (2026, January 13). Preventing Explosions in Exothermic Reaction Calorimetry. Retrieved from [[Link](#)]
- PRISM BioLab. (2023, November 15). Reaction Conditions Optimization: The Current State. Retrieved from [[Link](#)]
- ResearchGate. (n.d.). Effect of reaction time on the yield and purity of boric acid. Retrieved from [[Link](#)]
- LCGC International. (2023, June 19). Rapid Monitoring of Chemical Reactions Made Possible by Ultrahigh-Performance Liquid Chromatography. Retrieved from [[Link](#)]
- PubMed. (2009, April 15). Optimization and troubleshooting in PCR. Retrieved from [[Link](#)]
- WSU. (n.d.). Monitoring Reactions by TLC. Retrieved from [[Link](#)]

#### Need Custom Synthesis?

BenchChem offers custom synthesis for rare earth carbides and specific isotopic labeling.

Email: [info@benchchem.com](mailto:info@benchchem.com) or [Request Quote Online](#).

## Sources

- 1. [pdf.benchchem.com](https://pdf.benchchem.com) [[pdf.benchchem.com](https://pdf.benchchem.com)]
- 2. [Understanding the Temperature-Sensitive Nature of Drugs](https://pphealthcaresolutions.co.uk) [[pphealthcaresolutions.co.uk](https://pphealthcaresolutions.co.uk)]

- [3. Impact of temperature fluctuation on medicines | Mercatus Bioscience \[bioscience.mercatus.pt\]](#)
- [4. Rising temperatures can cause serious side effects with many medicines - health authority | Clean Energy Wire \[cleanenergywire.org\]](#)
- [5. Thermodynamic and kinetic reaction control - Wikipedia \[en.wikipedia.org\]](#)
- [6. pdf.benchchem.com \[pdf.benchchem.com\]](#)
- [7. masterorganicchemistry.com \[masterorganicchemistry.com\]](#)
- [8. Chromatographic Purity Analysis and Separation Services \[trcliniclabs.com\]](#)
- [9. pdf.benchchem.com \[pdf.benchchem.com\]](#)
- [10. s3.wp.wsu.edu \[s3.wp.wsu.edu\]](#)
- [11. mt.com \[mt.com\]](#)
- [12. scienceready.com.au \[scienceready.com.au\]](#)
- [13. terra-docs.s3.us-east-2.amazonaws.com \[terra-docs.s3.us-east-2.amazonaws.com\]](#)
- [14. academia.edu \[academia.edu\]](#)
- [15. homework.study.com \[homework.study.com\]](#)
- [16. chemrxiv.org \[chemrxiv.org\]](#)
- [17. taylorandfrancis.com \[taylorandfrancis.com\]](#)
- [18. Solvent- or Temperature-Controlled Diastereoselective Aldol Reaction of Methyl Phenylacetate \[organic-chemistry.org\]](#)
- [19. Exploring the Temperature Effect on Enantioselectivity of a Baeyer-Villiger Biooxidation by the 2,5-DKCMO Module: The SLM Approach - PMC \[pmc.ncbi.nlm.nih.gov\]](#)
- [20. enertherm-engineering.com \[enertherm-engineering.com\]](#)
- [21. A Practical Start-Up Guide for Synthetic Chemists to Implement Design of Experiments \(DoE\) - PMC \[pmc.ncbi.nlm.nih.gov\]](#)
- [22. mt.com \[mt.com\]](#)
- [23. Using Design of Experiments \(DoE\) in Method Development | Lab Manager \[labmanager.com\]](#)
- [24. Design of Experiments \(DOE\): A Comprehensive Guide to Experimental Planning and Analysis \[numiqo.com\]](#)
- [25. Reaction Conditions Optimization: The Current State - PRISM BioLab \[prismbiolab.com\]](#)
- [26. chromatographyonline.com \[chromatographyonline.com\]](#)

- [27. biotage.com \[biotage.com\]](#)
- [28. labproinc.com \[labproinc.com\]](#)
- [29. benchchem.com \[benchchem.com\]](#)
- [30. Handling Reaction Exotherms – A Continuous Approach - Chemical Industry Journal \[chemicalindustryjournal.co.uk\]](#)
- [31. Preventing Explosions in Exothermic Reaction Calorimetry | Lab Manager \[labmanager.com\]](#)
- To cite this document: BenchChem. [Technical Support Center: Optimizing Reaction Conditions for Product Purity]. BenchChem, [2026]. [Online PDF]. Available at: [\[https://www.benchchem.com/product/b11957818/docs#technical-support-center-optimizing-reaction-conditions-for-product-purity\]](https://www.benchchem.com/product/b11957818/docs#technical-support-center-optimizing-reaction-conditions-for-product-purity)

---

#### Disclaimer & Data Validity:

The information provided in this document is for Research Use Only (RUO) and is strictly not intended for diagnostic or therapeutic procedures. While BenchChem strives to provide accurate protocols, we make no warranties, express or implied, regarding the fitness of this product for every specific experimental setup.

**Technical Support:** The protocols provided are for reference purposes. Unsure if this reagent suits your experiment?

**Need Industrial/Bulk Grade?** [Request Custom Synthesis Quote](#)

## BenchChem

Our mission is to be the trusted global source of essential and advanced chemicals, empowering scientists and researchers to drive progress in science and industry.

#### Contact

Address: 3281 E Guasti Rd  
Ontario, CA 91761, United States  
Phone: (601) 213-4426  
Email: [info@benchchem.com](mailto:info@benchchem.com)

Contact our Ph.D. Support Team for a compatibility check