

Application Note & Protocol: Determination of Cyverine Dose-Response Curve

Author: BenchChem Technical Support Team. **Date:** April 2026

Compound of Interest

| | |
|----------------|-----------|
| Compound Name: | Cyverine |
| CAS No.: | 4432-75-1 |
| Cat. No.: | B1195482 |

[Get Quote](#)

Audience: Researchers, scientists, and drug development professionals.

Purpose: This document provides a detailed protocol for determining the half-maximal inhibitory concentration (IC50) of **Cyverine**, a hypothetical compound, by generating a dose-response curve using an in vitro cell-based assay.

Introduction

The dose-response relationship is a fundamental concept in pharmacology, describing the magnitude of a substance's effect in relation to its concentration.[1][2] Generating a dose-response curve is essential for characterizing the potency and efficacy of a new chemical entity.[2][3] This curve is typically sigmoidal, plotting the biological response against the logarithm of the drug concentration, which allows for the determination of key parameters like the IC50 (the concentration at which 50% of the maximum inhibitory effect is observed).[3]

For the purpose of this application note, we will characterize **Cyverine**, a hypothetical inhibitor of the pro-inflammatory "Cyto-Kinase Signaling Pathway." Understanding its potency through IC50 determination is a critical step in its preclinical evaluation.

Hypothetical Mechanism of Action of Cyverine

Cyverine is postulated to inhibit cellular proliferation by blocking a critical kinase in the Cytokine Kinase Signaling Pathway. This pathway is initiated by an external cytokine binding to its receptor, leading to a phosphorylation cascade that ultimately activates a transcription factor responsible for expressing genes involved in cell division. By inhibiting this kinase, **Cyverine** disrupts the signal transduction and halts the proliferative response.[4][5]

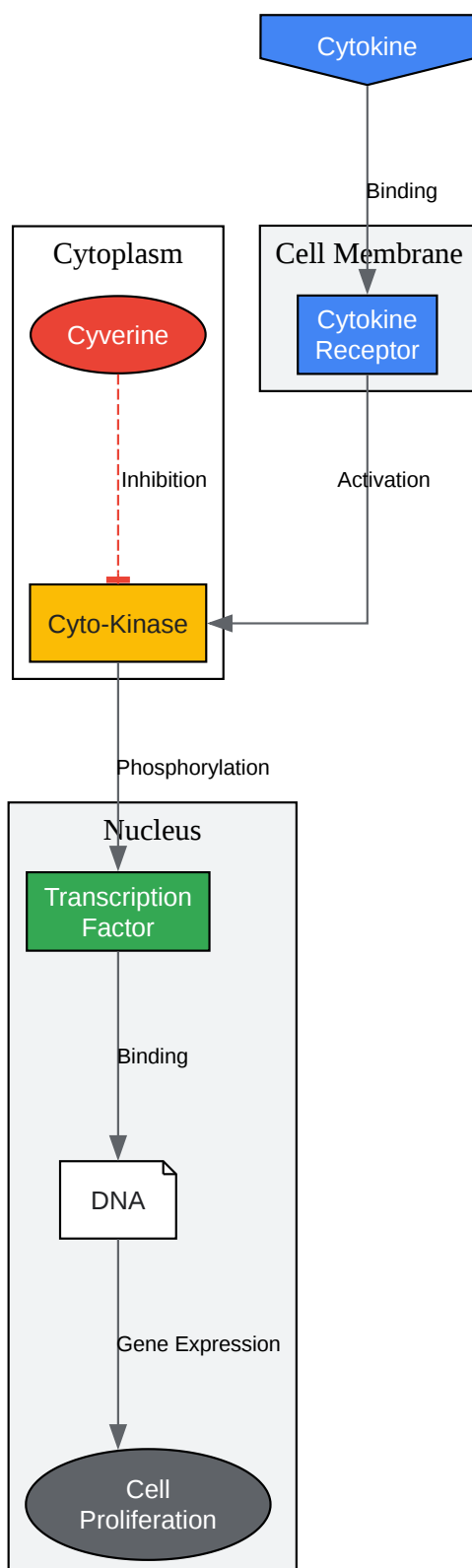

[Click to download full resolution via product page](#)

Caption: Hypothetical Cyto-Kinase Signaling Pathway inhibited by **Cyverine**.

Experimental Protocol: IC50 Determination

This protocol details the use of a Resazurin-based cell viability assay to generate a dose-response curve for **Cyverine**. Metabolically active cells reduce the blue, non-fluorescent Resazurin dye to the pink, highly fluorescent Resorufin.[6] The measured fluorescence is directly proportional to the number of viable cells.

Overall Experimental Workflow

The process involves seeding cells, treating them with a serial dilution of **Cyverine**, incubating to allow for drug action, adding the viability reagent, and finally measuring the output to determine the dose-dependent effect.

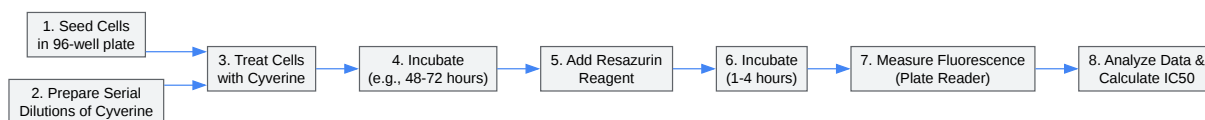

[Click to download full resolution via product page](#)

Caption: Workflow for determining the dose-response curve of **Cyverine**.

Materials and Reagents

| Material/Reagent | Example Supplier | Purpose |
|-------------------------------------|------------------|-------------------------------------|
| Human Cancer Cell Line (e.g., A549) | ATCC | Biological system for testing |
| DMEM/F-12 Medium | Thermo Fisher | Cell culture growth medium |
| Fetal Bovine Serum (FBS) | Thermo Fisher | Growth supplement for medium |
| Penicillin-Streptomycin | Thermo Fisher | Antibiotic to prevent contamination |
| Trypsin-EDTA | Thermo Fisher | Cell detachment for passaging |
| Phosphate-Buffered Saline (PBS) | Thermo Fisher | Washing cells |
| Cyverine Compound | N/A | Test article |
| Dimethyl Sulfoxide (DMSO) | Sigma-Aldrich | Solvent for Cyverine stock |
| Resazurin Sodium Salt | Sigma-Aldrich | Cell viability indicator |
| 96-well clear-bottom black plates | Corning | Plate for cell culture and assay |

Step-by-Step Methodology

Day 1: Cell Seeding

- Culture A549 cells in DMEM/F-12 supplemented with 10% FBS and 1% Penicillin-Streptomycin at 37°C and 5% CO₂.
- Harvest cells using Trypsin-EDTA and perform a cell count using a hemocytometer or automated cell counter.
- Dilute the cell suspension to a final concentration of 5×10^4 cells/mL.
- Seed 100 μ L of the cell suspension (5,000 cells/well) into each well of a 96-well plate.
- Include wells for "cells + vehicle" (negative control) and "media only" (background blank).

- Incubate the plate overnight to allow cells to attach.

Day 2: Compound Treatment

- Prepare a 10 mM stock solution of **Cyverine** in 100% DMSO.
- Perform a serial dilution of the **Cyverine** stock solution to create a range of concentrations. A common approach is a 10-point, 3-fold serial dilution.[7]
 - Start by creating a top working concentration (e.g., 200 μ M) in culture medium. The final DMSO concentration in all wells should be kept constant and low (e.g., $\leq 0.5\%$).
 - Serially dilute this solution to obtain concentrations spanning a wide range (e.g., 100 μ M down to 0.005 μ M).
- Carefully remove the old medium from the cells and add 100 μ L of the medium containing the respective **Cyverine** concentrations to the appropriate wells.
- Add 100 μ L of medium with vehicle (e.g., 0.5% DMSO) to the negative control wells.
- Incubate the plate for 48-72 hours.

Day 4: Cell Viability Measurement

- Prepare a 0.15 mg/mL working solution of Resazurin in sterile PBS.
- Add 20 μ L of the Resazurin solution to each well, including controls.
- Incubate the plate for 2-4 hours at 37°C, protected from light.
- Measure the fluorescence using a microplate reader with an excitation wavelength of ~560 nm and an emission wavelength of ~590 nm.

Data Presentation and Analysis

Data Calculation

- Correct for Background: Subtract the average fluorescence of the "media only" blank wells from all other wells.

- Calculate Percent Inhibition: Use the following formula for each concentration: % Inhibition = $100 * (1 - (\text{Fluorescence_Test} / \text{Fluorescence_VehicleControl}))$

Sample Data Table

This table shows representative data from a **Cyverine** dose-response experiment.

| Cyverine Conc. (µM) | Log [Cyverine] (M) | Avg. Fluorescence (Corrected) | % Inhibition |
|---------------------|--------------------|-------------------------------|--------------|
| 100.000 | -4.00 | 150 | 97.0% |
| 33.333 | -4.48 | 350 | 93.0% |
| 11.111 | -4.95 | 900 | 82.0% |
| 3.704 | -5.43 | 2100 | 58.0% |
| 1.235 | -5.91 | 3900 | 22.0% |
| 0.412 | -6.38 | 4800 | 4.0% |
| 0.137 | -6.86 | 5050 | -1.0% |
| 0.046 | -7.34 | 4950 | 1.0% |
| 0.015 | -7.82 | 5000 | 0.0% |
| 0 (Vehicle) | N/A | 5000 | 0.0% |

Generating the Dose-Response Curve

To determine the IC50, the data must be plotted and analyzed using non-linear regression.[\[7\]](#)
[\[8\]](#)

- Plot the % Inhibition (Y-axis) against the Logarithm of the molar concentration of **Cyverine** (X-axis).[\[9\]](#)
- Fit the data to a sigmoidal dose-response (variable slope) equation, often referred to as a four-parameter logistic (4PL) model.[\[10\]](#)

- Software such as GraphPad Prism, R, or Python can be used for this analysis.[8] The software will calculate the best-fit value for the IC50.

Summary of Results

The analysis yields key parameters that characterize the potency of the compound.

| Parameter | Value | 95% Confidence Interval | Description |
|----------------|-------------|-------------------------|-----------------------------------|
| IC50 | 3.1 μ M | 2.5 - 3.8 μ M | Concentration for 50% inhibition. |
| Hill Slope | -1.1 | -0.9 to -1.3 | Steepness of the curve. |
| R ² | 0.995 | N/A | Goodness of fit of the curve. |

Conclusion

This application note provides a robust and detailed protocol for determining the dose-response curve and IC50 value of the hypothetical compound **Cyverine**. The described cell-based assay is a fundamental technique in drug discovery, allowing for the quantitative assessment of a compound's potency.[11] Accurate determination of the IC50 is crucial for comparing different compounds, understanding structure-activity relationships, and guiding further drug development efforts.[2]

Need Custom Synthesis?

BenchChem offers custom synthesis for rare earth carbides and specific isotopic labeling.

Email: info@benchchem.com or [Request Quote Online](#).

References

- [1. Dose Response Curve | Definition, Equation & Examples - Lesson | Study.com \[study.com\]](#)

- [2. lifesciences.danaher.com](https://lifesciences.danaher.com) [lifesciences.danaher.com]
- [3. collaboratedrug.com](https://collaboratedrug.com) [collaboratedrug.com]
- [4. sinobiological.com](https://sinobiological.com) [sinobiological.com]
- [5. Cytokines Signal Transduction - Creative BioMart](https://creativebiomart.net) [creativebiomart.net]
- [6. Cell Viability Assays - Assay Guidance Manual - NCBI Bookshelf](https://ncbi.nlm.nih.gov) [ncbi.nlm.nih.gov]
- [7. How Do I Perform a Dose-Response Experiment? - FAQ 2188 - GraphPad](https://graphpad.com) [graphpad.com]
- [8. researchgate.net](https://researchgate.net) [researchgate.net]
- [9. pubs.acs.org](https://pubs.acs.org) [pubs.acs.org]
- [10. Star Republic: Guide for Biologists](https://sciencegateway.org) [sciencegateway.org]
- [11. The dose-response relationship in phase I clinical trials and beyond: use, meaning, and assessment - PubMed](https://pubmed.ncbi.nlm.nih.gov) [pubmed.ncbi.nlm.nih.gov]
- To cite this document: BenchChem. [Application Note & Protocol: Determination of Cyverine Dose-Response Curve]. BenchChem, [2026]. [Online PDF]. Available at: [<https://www.benchchem.com/product/b1195482/docs#application-note-protocol-determination-of-cyverine-dose-response-curve>]

Disclaimer & Data Validity:

The information provided in this document is for Research Use Only (RUO) and is strictly not intended for diagnostic or therapeutic procedures. While BenchChem strives to provide accurate protocols, we make no warranties, express or implied, regarding the fitness of this product for every specific experimental setup.

Technical Support: The protocols provided are for reference purposes. Unsure if this reagent suits your experiment?

Need Industrial/Bulk Grade? [Request Custom Synthesis Quote](#)

BenchChem

Our mission is to be the trusted global source of essential and advanced chemicals, empowering scientists and researchers to drive progress in science and industry.

Contact

Address: 3281 E Guasti Rd
Ontario, CA 91761, United States
Phone: (601) 213-4426
Email: info@benchchem.com

[Contact our Ph.D. Support Team for a compatibility check](#)