

Spectral Fingerprinting of Malonamides: A Comparative FTIR Guide

Author: BenchChem Technical Support Team. **Date:** May 2026

Compound of Interest

Compound Name: 2-Benzylpropanediamide

CAS No.: 1846-13-5

Cat. No.: B11949359

[Get Quote](#)

Executive Summary Malonamides (

) represent a unique structural class in medicinal chemistry, serving as versatile bioisosteres for peptides and chelating agents in metallodrug development. Their diagnostic utility relies heavily on the vibrational coupling between the two carbonyl groups separated by a single methylene bridge. This guide provides a technical comparison of the FTIR absorption characteristics of primary malonamide groups against standard monoamides, emphasizing the spectral anomalies caused by intramolecular hydrogen bonding and vibrational coupling.

Part 1: The Malonamide Signature (The "Product")

Unlike simple monoamides (e.g., acetamide), malonamides possess two amide groups in close proximity (

-position). This structural proximity leads to vibrational coupling and intramolecular hydrogen bonding, creating a spectral signature that is distinct from standard peptide bonds.

Core Absorption Bands

The following table details the primary infrared absorption bands for unsubstituted primary malonamides in the solid state.

Band Assignment	Wavenumber (cm ⁻¹)	Vibrational Mode	Diagnostic Feature
Amide A	3350 – 3180	Asymmetric & Symmetric Stretch	Split Peak: Distinct doublet often observed. Lower frequency shift indicates strong H-bonding.[1]
Amide I	1690 – 1640	Carbonyl Stretch	The "Malonamide Doublet": Often appears as a split band or broadened shoulder due to coupling between the two carbonyls.
Amide II	1620 – 1580	Bending + Stretch	High Intensity: Stronger relative intensity compared to secondary amides.
Amide III	1420 – 1400	Stretch +	Methylene Interaction: Often overlaps with scissoring modes of the bridge.

The "Coupled Oscillator" Mechanism

In a standard monoamide, the Amide I band is a single, sharp peak. In malonamides, the two carbonyl dipoles interact through the methylene bridge. This interaction creates two normal modes:

- Symmetric Stretching: Both

bonds expand simultaneously (Higher energy, $\sim 1680\text{ cm}^{-1}$).

- Asymmetric Stretching: One

expands while the other contracts (Lower energy, $\sim 1650\text{ cm}^{-1}$).

Note: In solid-state samples (KBr pellet), this splitting is often obscured by lattice intermolecular hydrogen bonding, resulting in a single, broad, asymmetric band.

Part 2: Comparative Analysis (The "Alternatives")

To validate the presence of a malonamide moiety, one must distinguish it from chemically similar alternatives.

Comparison 1: Malonamide vs. Primary Monoamide (e.g., Acetamide)

Performance Metric: Spectral Resolution & Band Shape

Feature	Malonamide (Target)	Acetamide (Alternative)	Interpretation
Amide I Band	Broad/Split (Doublet)	Sharp Singlet	The "Doublet" confirms the presence of interacting carbonyls (-dicarbonyl system).
H-Bonding	Intramolecular (6-membered ring)	Intermolecular only	Malonamide bands are less sensitive to dilution in non-polar solvents (see Protocol).
	Active Methylene (~2900 cm^{-1})	Methyl only (~2960 cm^{-1})	The acidic methylene bridge in malonamides shows distinct C-H stretching.

Comparison 2: Primary vs. Secondary Malonamides

Performance Metric: N-H Stretching Region (Amide A)

- Primary Malonamide (): Shows two distinct bands in the 3400–3200 cm^{-1} region (Asymmetric and Symmetric stretch).
- Secondary Malonamide (): Shows only one band in this region.
- Tertiary Malonamide (): No bands in the 3400–3200 cm^{-1} region.

Part 3: Mechanistic Insights & Visualization

The spectral anomalies in malonamides are driven by the formation of a pseudo-six-membered ring via intramolecular hydrogen bonding between one amide hydrogen and the carbonyl oxygen of the adjacent group.

Structural Diagram: The H-Bond Network

The following diagram illustrates the vibrational coupling and the competing hydrogen bond networks.

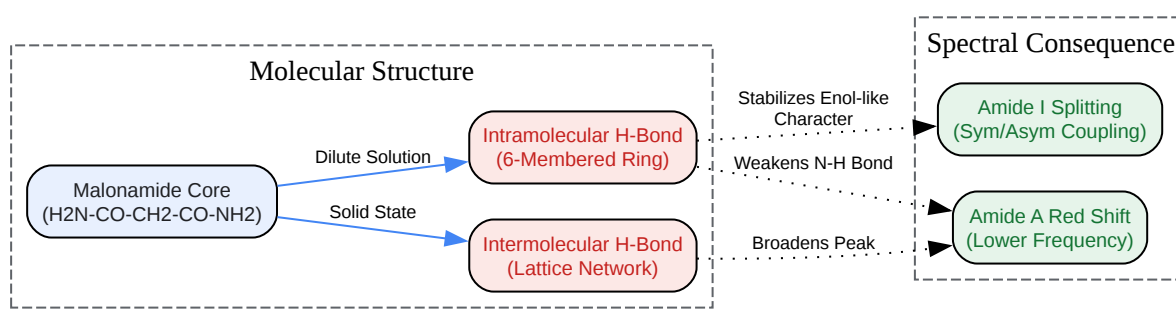

[Click to download full resolution via product page](#)

Part 4: Experimental Protocol

To rigorously distinguish between intermolecular (concentration-dependent) and intramolecular (structure-dependent) hydrogen bonding in malonamides, the following self-validating protocol is recommended.

Method: Dilution Series Analysis

Objective: Confirm the "Malonamide Signature" by eliminating intermolecular lattice effects.

Reagents:

- Analyte: Malonamide derivative (Dry solid).
- Solvent: Anhydrous Chloroform (

) or Carbon Tetrachloride (

). Note: Solvents must be non-polar to avoid competing H-bonds.

Step-by-Step Workflow:

- Baseline (Solid State):
 - Prepare a KBr pellet (1-2% w/w sample in KBr).[2]
 - Acquire spectrum (32 scans, 4 cm^{-1} resolution).
 - Observation: Expect broad, merged bands due to lattice packing.
- Solution Preparation (High Conc.):
 - Dissolve sample in
to 0.1 M.
 - Acquire spectrum using a liquid cell (CaF_2 windows).
- Dilution (Validation Step):
 - Serially dilute the solution to 0.01 M and 0.001 M.
 - Acquire spectra at each step.[2]
- Data Interpretation (The "Self-Check"):
 - Intermolecular H-bonds: Bands will shift to higher frequency and sharpen as concentration decreases (bonds break).
 - Intramolecular H-bonds (Malonamide Ring): Bands will remain constant in position regardless of dilution. This confirms the specific malonamide folded conformation.

Decision Tree for Spectral Identification

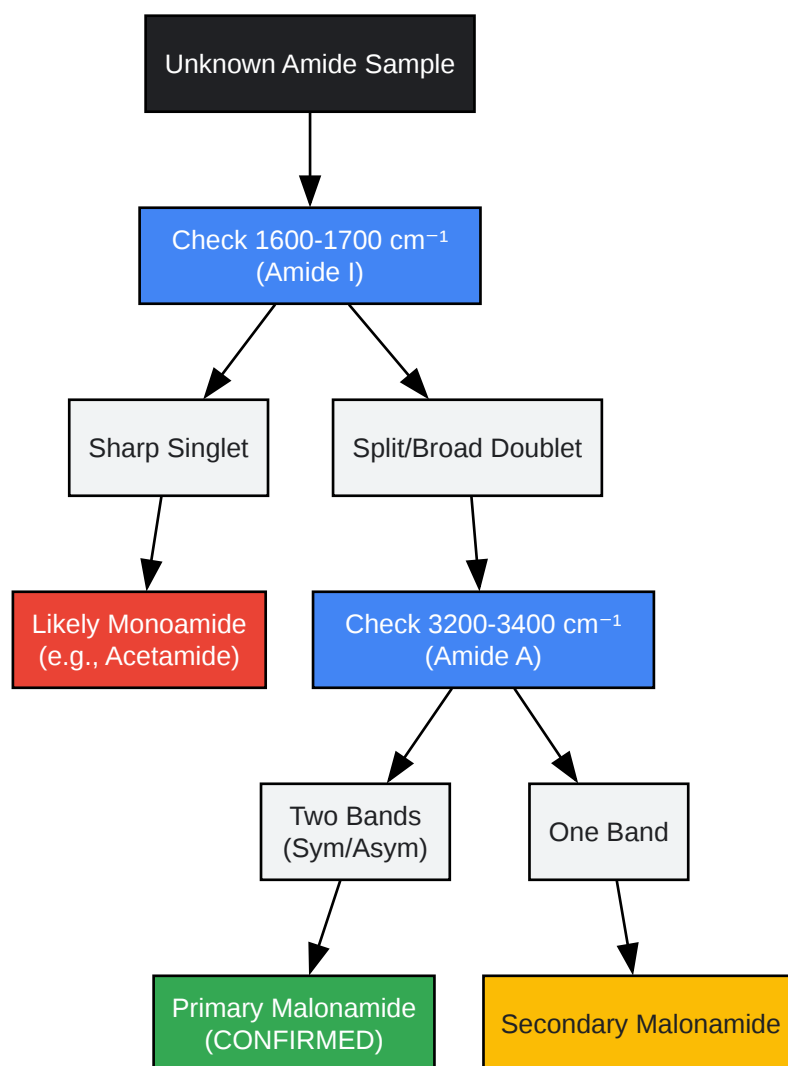

[Click to download full resolution via product page](#)

References

- Barth, A. (2007). Infrared spectroscopy of proteins. *Biochimica et Biophysica Acta (BBA) - Bioenergetics*, 1767(9), 1073-1101. [Link](#)
- Dziembowska, T., et al. (2005). Theoretical study of malonamide and nitromalonamide in vacuum and in water solution. *Journal of Molecular Structure: THEOCHEM*, 719(1-3), 137-148. [Link](#)
- Takasuka, M., et al. (1991).[3] FTIR spectral study of intramolecular hydrogen bonding in thromboxane A2 receptor antagonist S-145 and related compounds. *Journal of Medicinal Chemistry*, 34(6), 1885-1891.[3] [Link](#)

- Specac Ltd. (n.d.). Interpreting Infrared Spectra: Amide Groups. Specac Knowledge Base. [Link](#)
- LibreTexts. (2024). Infrared Spectra of Some Common Functional Groups: Amides. Chemistry LibreTexts. [Link](#)

Need Custom Synthesis?

BenchChem offers custom synthesis for rare earth carbides and specific isotopic labeling.

Email: info@benchchem.com or [Request Quote Online](#).

Sources

- [1. researchgate.net \[researchgate.net\]](https://www.researchgate.net)
- [2. eng.uc.edu \[eng.uc.edu\]](https://eng.uc.edu)
- [3. FTIR spectral study of intramolecular hydrogen bonding in thromboxane A2 receptor antagonist S-145 and related compounds. 3. Conformation and activity of S-145 analogues - PubMed \[pubmed.ncbi.nlm.nih.gov\]](https://pubmed.ncbi.nlm.nih.gov)
- To cite this document: BenchChem. [Spectral Fingerprinting of Malonamides: A Comparative FTIR Guide]. BenchChem, [2026]. [Online PDF]. Available at: [\[https://www.benchchem.com/product/b11949359/docs#spectral-fingerprinting-of-malonamides-a-comparative-ftir-guide\]](https://www.benchchem.com/product/b11949359/docs#spectral-fingerprinting-of-malonamides-a-comparative-ftir-guide)

Disclaimer & Data Validity:

The information provided in this document is for Research Use Only (RUO) and is strictly not intended for diagnostic or therapeutic procedures. While BenchChem strives to provide accurate protocols, we make no warranties, express or implied, regarding the fitness of this product for every specific experimental setup.

Technical Support: The protocols provided are for reference purposes. Unsure if this reagent suits your experiment?

Need Industrial/Bulk Grade? [Request Custom Synthesis Quote](#)

BenchChem

Our mission is to be the trusted global source of essential and advanced chemicals, empowering scientists and researchers to drive progress in science and industry.

Contact

Address: 3281 E Guasti Rd

Ontario, CA 91761, United States

Phone: (601) 213-4426

Email: info@benchchem.com

[Contact our Ph.D. Support Team for a compatibility check](#)