

# Technical Guide: UV-Vis Absorption Maxima of Semicarbazone Metal Complexes

**Author:** BenchChem Technical Support Team. **Date:** May 2026

## Compound of Interest

Compound Name:	1-(2,3-Dihydroxybenzylidene)semicarbazide
CAS No.:	106324-34-9
Cat. No.:	B11940214

[Get Quote](#)

## Executive Summary

**Audience:** Researchers, Medicinal Chemists, and Spectroscopists. **Purpose:** To provide a rigorous, data-driven comparison of the ultraviolet-visible (UV-Vis) spectral behaviors of semicarbazone ligands versus their transition metal complexes. This guide focuses on the mechanistic origins of spectral shifts (bathochromic/hypsochromic) and establishes a validated protocol for using UV-Vis data to confirm metal coordination in drug development pipelines.

## Theoretical Framework: Electronic Transitions

Semicarbazones (

) are versatile pharmacophores.<sup>[1][2]</sup> Their biological efficacy—often enhanced by metal complexation—relies on the electronic environment of the azomethine (

) and carbonyl (

) groups.

## The Ligand Baseline

Free semicarbazone ligands typically exhibit two primary absorption bands in the UV region:

- High Energy Band (200–280 nm): Assigned to transitions of the aromatic rings (benzenoid) and the chromophore.
- Medium Energy Band (280–350 nm): Assigned to transitions involving the lone pairs on the azomethine nitrogen or carbonyl oxygen.

## The Complexation Shift (The "Fingerprint")

Upon coordination with metal ions (e.g., Cu(II), Ni(II), Co(II), Zn(II)), these bands shift. The direction and magnitude of this shift are diagnostic of the coordination mode.

- Bathochromic Shift (Red Shift): Most common. The coordination of the metal to the azomethine nitrogen stabilizes the excited state more than the ground state (or destabilizes the orbital less than the orbital), reducing the energy gap ( ).
- Ligand-to-Metal Charge Transfer (LMCT): New bands appear in the visible region (350–450 nm), often obscuring weaker d-d transitions.
- d-d Transitions: Weak bands in the visible region (400–800 nm) specific to the metal's d-electron configuration and geometry (octahedral vs. square planar).

## Comparative Analysis: Ligand vs. Complex

The following data synthesizes literature values for salicylaldehyde semicarbazone derivatives and their metal complexes.

**Table 1: Comparative UV-Vis Absorption Maxima (nm) [3]**

Compound	(nm)	(nm)	LMCT / d-d (nm)	Shift Type	Geometry Indication
Free Ligand (L)	286	316	N/A	Reference	N/A
Cu(II) Complex	290 (+4)	350 (+34)	404, 620	Bathochromic	Square Planar / Octahedral
Ni(II) Complex	288 (+2)	348 (+32)	452	Bathochromic	Octahedral
Co(II) Complex	289 (+3)	353 (+37)	481, 534	Bathochromic	Octahedral (High Spin)
Zn(II) Complex	288 (+2)	345 (+29)	428 (CT only)	Bathochromic	Tetrahedral / Octahedral

Note: Data represents average values from salicylaldehyde-based semicarbazone derivatives in DMSO/DMF.

## Mechanistic Insights by Metal Ion

- Copper ( $\text{Cu}^{2+}$ ): Often exhibits a broad band near 600–650 nm due to the transition (Jahn-Teller distorted octahedral). The intense band near 400 nm is typically LMCT ( ).
- Nickel ( $\text{Ni}^{2+}$ ): Octahedral complexes show three spin-allowed transitions. The band around 450 nm corresponds to .
- Zinc ( $\text{Zn}^{2+}$ ): As a

system, Zn(II) shows no d-d transitions. Any visible color or absorption above 400 nm is strictly due to Charge Transfer (ligand-to-metal) or intraligand shifts. This makes UV-Vis a binary "yes/no" test for Zn complexation purity (absence of d-d bands).

## Experimental Protocol: Synthesis & Characterization

This protocol is designed to be self-validating. If the UV-Vis shift is not observed, coordination has likely failed.

### Workflow Diagram

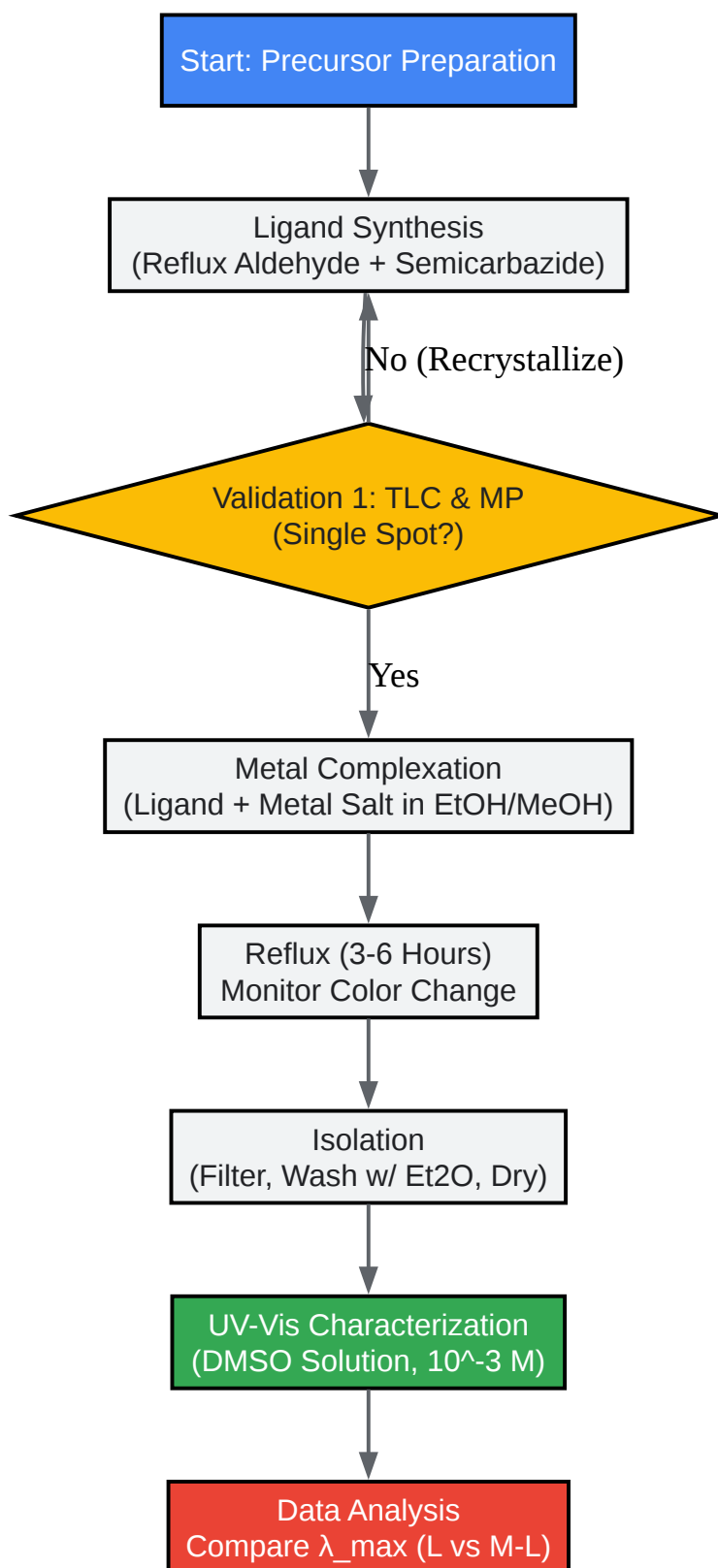

[Click to download full resolution via product page](#)

Caption: Step-by-step workflow for the synthesis and UV-Vis validation of semicarbazone metal complexes.

## Detailed Methodology

### Step 1: Ligand Synthesis

- Dissolve 10 mmol of the aldehyde (e.g., salicylaldehyde) in 20 mL ethanol.
- Add equimolar semicarbazide hydrochloride (dissolved in minimal water with sodium acetate).
- Reflux for 2–4 hours. Cool to precipitate.<sup>[3]</sup> Recrystallize from ethanol.
- Checkpoint: Confirm purity via TLC (single spot) and Melting Point.

### Step 2: Metal Complexation

- Dissolve 1 mmol of the purified ligand in 20 mL hot methanol/ethanol.
- Add 1 mmol of metal salt ( , or ) dissolved in 10 mL solvent dropwise.
- Observation: Immediate color change is the first indicator of complexation.
- Reflux for 3–6 hours.
- Filter the precipitate, wash with cold ethanol (to remove unreacted ligand) and diethyl ether (to dry).

### Step 3: UV-Vis Measurement

- Solvent: Prepare

M stock solutions of both the free ligand and the complex in DMSO or DMF. (Note: Ethanol may not dissolve the complex).

- Blank: Use pure solvent as the baseline.
- Scan: Record spectra from 200 nm to 800 nm.
- Validation: Overlay the spectra. You must observe:
  - Shift of the ligand band ( ) to a higher wavelength (>10 nm shift).
  - Appearance of new low-intensity bands in the 400–700 nm region (for Cu, Ni, Co).

## Mechanism of Action: Why the Shift Occurs?

To interpret the data correctly, one must understand the molecular orbital interactions.

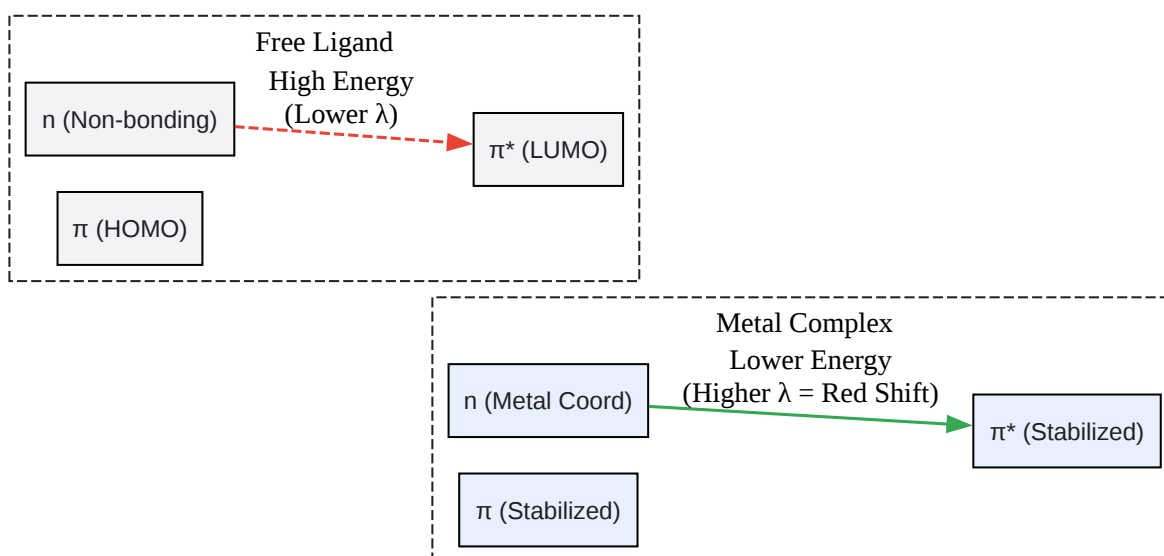

[Click to download full resolution via product page](#)

Caption: Energy level diagram illustrating the reduction in energy gap (

) for

transitions upon metal coordination.

Explanation: The non-bonding (

) electrons of the azomethine nitrogen are involved in bond formation with the metal ion. While this stabilizes the orbital, the excited

state is often stabilized more significantly due to back-donation or conjugation extension, resulting in a net decrease in the transition energy (

). A smaller

results in a larger

(Bathochromic shift).

## References

- More, M. S., et al. (2019).[4] Metal complexes driven from Schiff bases and semicarbazones for biomedical and allied applications: a review. *Materials Today: Proceedings*.
- Al-Amiry, A. A., et al. (2012). Design, biological evaluation, solvatochromic, DFT, and molecular docking studies of new metal complexes derived from a semicarbazone ligand. *Scientific Reports*.
- Chandra, S., & Kumar, A. (2005). Synthesis and spectroscopic characterization of Schiff base metal complexes. *Spectrochimica Acta Part A*.
- Lobana, T. S., et al. (2009). Bonding and structure trends of thiosemicarbazone derivatives of metals—An overview. *Coordination Chemistry Reviews*.
- Suslick, K. S. (2013). *Electronic Spectroscopy of Transition Metal Complexes*. University of Illinois.

### Need Custom Synthesis?

BenchChem offers custom synthesis for rare earth carbides and specific isotopic labeling.

Email: [info@benchchem.com](mailto:info@benchchem.com) or [Request Quote Online](#).

## Sources

- 1. Synthesis, characterization, computational studies and biological activity evaluation of Cu, Fe, Co and Zn complexes with 2-butanone thiosemicarbazone and 1,10-phenanthroline ligands as anticancer and antibacterial agents - PMC [[pmc.ncbi.nlm.nih.gov](https://pubmed.ncbi.nlm.nih.gov/)]
- 2. Design, biological evaluation, solvatochromic, DFT, and molecular docking studies of new metal complexes derived from a semicarbazone ligand - PMC [[pmc.ncbi.nlm.nih.gov](https://pubmed.ncbi.nlm.nih.gov/)]
- 3. [scispace.com](https://www.scispace.com) [[scispace.com](https://www.scispace.com)]
- 4. [portal.findresearcher.sdu.dk](https://portal.findresearcher.sdu.dk) [[portal.findresearcher.sdu.dk](https://portal.findresearcher.sdu.dk)]
- To cite this document: BenchChem. [Technical Guide: UV-Vis Absorption Maxima of Semicarbazone Metal Complexes]. BenchChem, [2026]. [Online PDF]. Available at: [<https://www.benchchem.com/product/b11940214/docs#technical-guide-uv-vis-absorption-maxima-of-semicarbazone-metal-complexes>]

---

### Disclaimer & Data Validity:

The information provided in this document is for Research Use Only (RUO) and is strictly not intended for diagnostic or therapeutic procedures. While BenchChem strives to provide accurate protocols, we make no warranties, express or implied, regarding the fitness of this product for every specific experimental setup.

**Technical Support:** The protocols provided are for reference purposes. Unsure if this reagent suits your experiment?

**Need Industrial/Bulk Grade?** [Request Custom Synthesis Quote](#)

# BenchChem

Our mission is to be the trusted global source of essential and advanced chemicals, empowering scientists and researchers to drive progress in science and industry.

## Contact

Address: 3281 E Guasti Rd

Ontario, CA 91761, United States

Phone: (601) 213-4426

Email: [info@benchchem.com](mailto:info@benchchem.com)

[Contact our Ph.D. Support Team for a compatibility check](#)