

The Pivotal Role of Malonyl-CoA in Cellular Metabolism: A Technical Guide

Author: BenchChem Technical Support Team. **Date:** December 2025

Compound of Interest

Compound Name: Malonyl CoA

Cat. No.: B1194419

[Get Quote](#)

For Researchers, Scientists, and Drug Development Professionals

Abstract

Malonyl-Coenzyme A (Malonyl-CoA) stands as a central figure in the intricate landscape of cellular metabolism. Far more than a simple intermediate, it functions as a critical metabolic sensor and regulator, orchestrating the delicate balance between energy storage and expenditure. This technical guide provides an in-depth exploration of the primary functions of Malonyl-CoA, delving into its core roles in fatty acid biosynthesis and the regulation of fatty acid oxidation. We will examine the key enzymatic players that govern its cellular concentration and explore its involvement in crucial signaling pathways that impact cellular growth, appetite, and insulin secretion. This document aims to provide a comprehensive resource for researchers and professionals in drug development, complete with quantitative data, detailed experimental protocols, and visual representations of the key pathways involving this multifaceted molecule.

Core Functions of Malonyl-CoA: A Dichotomy of Synthesis and Regulation

Malonyl-CoA's primary functions within the cell are twofold and seemingly paradoxical: it is the fundamental building block for the synthesis of fatty acids, and simultaneously, a potent inhibitor of their breakdown. This dual role positions Malonyl-CoA as a master switch that dictates the flow of carbon between anabolic and catabolic pathways, ensuring that the cell efficiently manages its energy resources.^[1]

The Building Block of Lipogenesis: Fueling Fatty Acid Synthesis

In the cytosol, Malonyl-CoA serves as the direct precursor for the de novo synthesis of fatty acids.[2] The enzyme acetyl-CoA carboxylase (ACC) catalyzes the carboxylation of acetyl-CoA to form Malonyl-CoA, a committed step in this pathway.[3] The two-carbon units from Malonyl-CoA are then sequentially added to a growing acyl chain by the multi-enzyme complex fatty acid synthase (FAS), ultimately leading to the formation of palmitate, a 16-carbon saturated fatty acid.[2][4] This process is fundamental for the storage of excess energy in the form of triglycerides and for the production of essential lipids for membrane structure and signaling.

The Gatekeeper of Fatty Acid Oxidation: Allosteric Inhibition of CPT1

Beyond its role in synthesis, cytosolic Malonyl-CoA acts as a powerful allosteric inhibitor of carnitine palmitoyltransferase 1 (CPT1).[5][6] CPT1 is the rate-limiting enzyme in the transport of long-chain fatty acids into the mitochondria for β -oxidation.[6][7] By binding to CPT1, Malonyl-CoA prevents the entry of fatty acids into the mitochondrial matrix, effectively halting their breakdown for energy production.[5] This inhibitory action is crucial for preventing a futile cycle where newly synthesized fatty acids are immediately oxidized.[8]

Quantitative Insights into Malonyl-CoA Dynamics

The cellular concentration of Malonyl-CoA and the kinetic properties of the enzymes that regulate it are critical determinants of its function. The following tables summarize key quantitative data from various studies.

Tissue/Cell Type	Condition	Malonyl-CoA Concentration (nmol/g wet weight)	Reference
Rat Liver	Fed	1.9 ± 0.6	[9]
Rat Heart	Fed	1.3 ± 0.4	[9]
Rat Skeletal Muscle	Fed	0.7 ± 0.2	[9]
Human Skeletal Muscle	Fasting	~1.5	[10]
Human Skeletal Muscle	Hyperglycemia/Hyperinsulinemia	~2.5	[10]
Mouse Hypothalamus	Ad libitum fed	~0.4	[11]
Mouse Hypothalamus	C75 (FAS inhibitor) treated	~0.4 (restored to fed levels)	[11]

Enzyme	Substrate/Inhibitor	Kinetic Parameter	Value	Tissue/Organism	Reference
Acetyl-CoA Carboxylase (ACC)	Acetyl-CoA	Km	4 μ M (CoA-activated)	Rat Liver	[12]
Acetyl-CoA Carboxylase (ACC)	Acetyl-CoA	Km	0.4 mM (control)	Rat Liver	[12]
Carnitine Palmitoyltransferase 1 (CPT1)	Malonyl-CoA	IC50	0.8 μ M	Rat Heart Mitochondria	[13]
Carnitine Palmitoyltransferase 1 (CPT1)	Malonyl-CoA	IC50	~1-2 μ M	Neonatal Cardiac Myocytes	[14]
Carnitine Palmitoyltransferase 1 (CPT1)	Malonyl-CoA	IC50	~13-18 fold higher in permeabilized muscle fibers vs. isolated mitochondria	Human Skeletal Muscle	[15]
Carnitine Palmitoyltransferase 1 (CPT1) - Liver Isoform	Malonyl-CoA	Inhibition	Requires ~10x higher concentration than muscle isoform	Rat	[16]

Key Signaling Pathways Involving Malonyl-CoA

Malonyl-CoA is not just a metabolite but also a key signaling molecule that integrates nutritional status with cellular growth and function.

Regulation of Fatty Acid Metabolism

The central role of Malonyl-CoA in regulating fatty acid synthesis and oxidation is depicted in the following pathway.

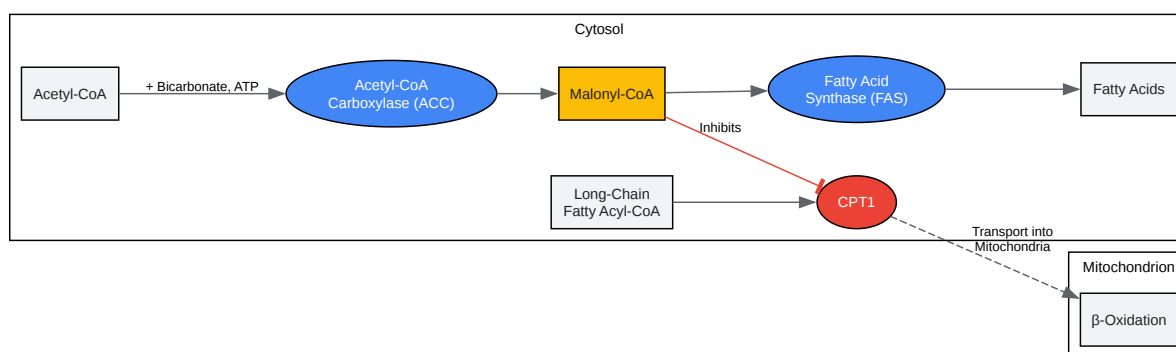

[Click to download full resolution via product page](#)

Fig. 1: Malonyl-CoA's central role in fatty acid metabolism.

AMPK Signaling: The Energy Sensor

AMP-activated protein kinase (AMPK) is a crucial energy sensor that is activated under conditions of low cellular energy (high AMP/ATP ratio). Activated AMPK phosphorylates and inactivates ACC, leading to a decrease in Malonyl-CoA levels. This relieves the inhibition on CPT1, allowing for fatty acid oxidation to generate ATP.^{[1][3]}

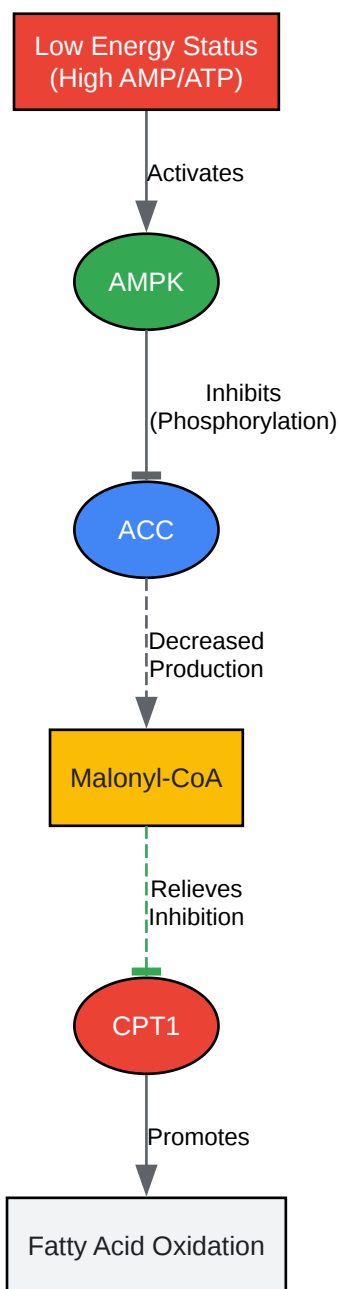

[Click to download full resolution via product page](#)

Fig. 2: AMPK-mediated regulation of Malonyl-CoA.

mTORC1 Signaling: A Link to Cell Growth

Recent evidence has shown that Malonyl-CoA can directly inhibit the mechanistic target of rapamycin complex 1 (mTORC1), a key regulator of cell growth and proliferation.[4][17] When fatty acid synthesis is impaired, the resulting accumulation of Malonyl-CoA acts as an ATP-

competitive inhibitor of mTORC1, thus linking lipid metabolism to the overall control of cell growth.[4][17]

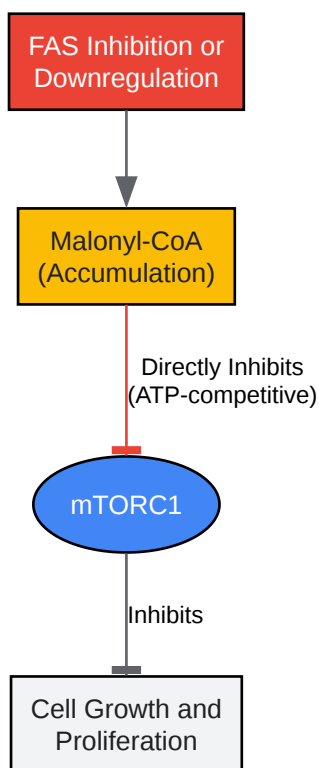

[Click to download full resolution via product page](#)

Fig. 3: Malonyl-CoA as a direct inhibitor of mTORC1.

Hypothalamic Regulation of Appetite

In the hypothalamus, Malonyl-CoA acts as an anorexigenic signal, indicating a state of energy surplus and thereby suppressing food intake.[6][18] Hormones like leptin can increase hypothalamic Malonyl-CoA levels, contributing to their appetite-suppressing effects.[18] Conversely, orexigenic signals like ghrelin can decrease hypothalamic Malonyl-CoA.[18]

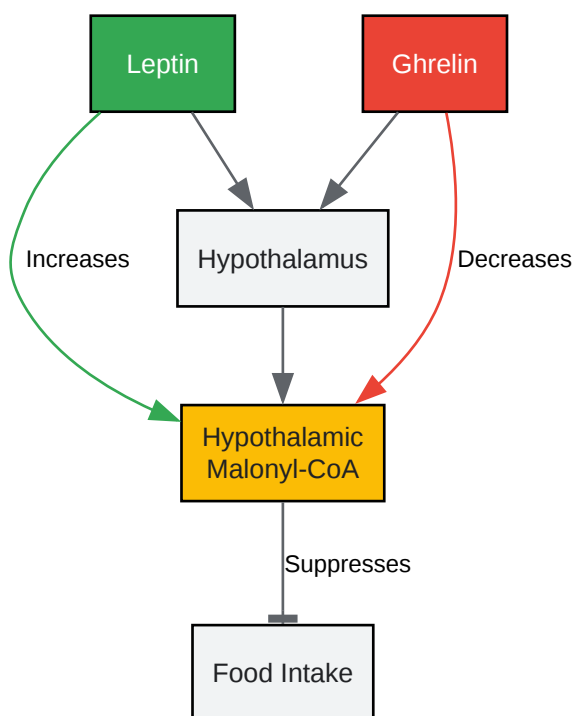

[Click to download full resolution via product page](#)

Fig. 4: Role of hypothalamic Malonyl-CoA in appetite control.

Regulation of Insulin Secretion

In pancreatic β -cells, glucose metabolism leads to an increase in Malonyl-CoA levels. This inhibits fatty acid oxidation and promotes the formation of lipid signaling molecules that enhance glucose-stimulated insulin secretion.[19][20]

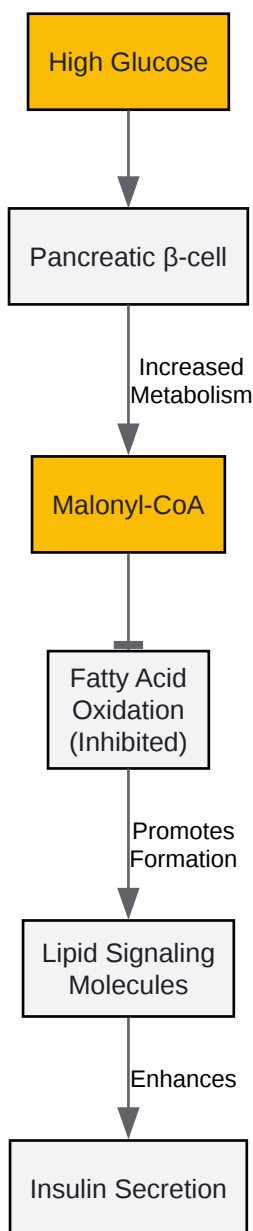

[Click to download full resolution via product page](#)

Fig. 5: Malonyl-CoA's involvement in insulin secretion.

Experimental Protocols: A Methodological Overview

Accurate measurement of Malonyl-CoA and the activity of its related enzymes is crucial for research in this field. Below are summaries of key experimental methodologies.

Quantification of Malonyl-CoA in Tissues

Principle: This method involves the extraction of Malonyl-CoA from tissue samples, followed by separation and quantification using high-performance liquid chromatography coupled with mass spectrometry (HPLC/MS).[9] An isotopically labeled internal standard is used for accurate quantification.[9]

Methodology:

- Tissue Homogenization: Snap-freeze tissue samples in liquid nitrogen and homogenize in a cold solution of 10% trichloroacetic acid.[9]
- Extraction: Centrifuge the homogenate to pellet proteins. The supernatant containing Malonyl-CoA is collected.
- Solid-Phase Extraction: The supernatant is passed through a reversed-phase solid-phase extraction column to isolate and concentrate the acyl-CoAs.[9]
- HPLC/MS Analysis: The extracted sample is injected into an HPLC system for separation, followed by detection and quantification using an electrospray mass spectrometer.[9] Quantification is achieved by comparing the peak area of the analyte to that of the known concentration of the internal standard.[9]



[Click to download full resolution via product page](#)

Fig. 6: Workflow for Malonyl-CoA quantification.

Acetyl-CoA Carboxylase (ACC) Activity Assay

Principle: ACC activity is determined by measuring the rate of Malonyl-CoA production. A coupled-enzyme spectrophotometric assay is commonly used, where the Malonyl-CoA produced is immediately consumed in a subsequent reaction that can be monitored.[21][22]

Methodology:

- Cell Permeabilization: For measurements in intact cells, the plasma membrane is permeabilized using digitonin to allow substrates to enter.[21]

- Reaction Mixture: The permeabilized cells or cell lysate is incubated in a reaction buffer containing acetyl-CoA, ATP, bicarbonate, and a coupling enzyme system.[21]
- Coupled Reaction: The assay often includes fatty acid synthase (FAS) and NADPH. The consumption of NADPH, which is proportional to the amount of Malonyl-CoA produced and then used by FAS, is monitored by the decrease in absorbance at 340 nm.[21] Alternatively, a malonyl-CoA reductase can be used to couple the reaction to NADPH oxidation.[22]
- Calculation: The rate of NADPH consumption is used to calculate the ACC activity.

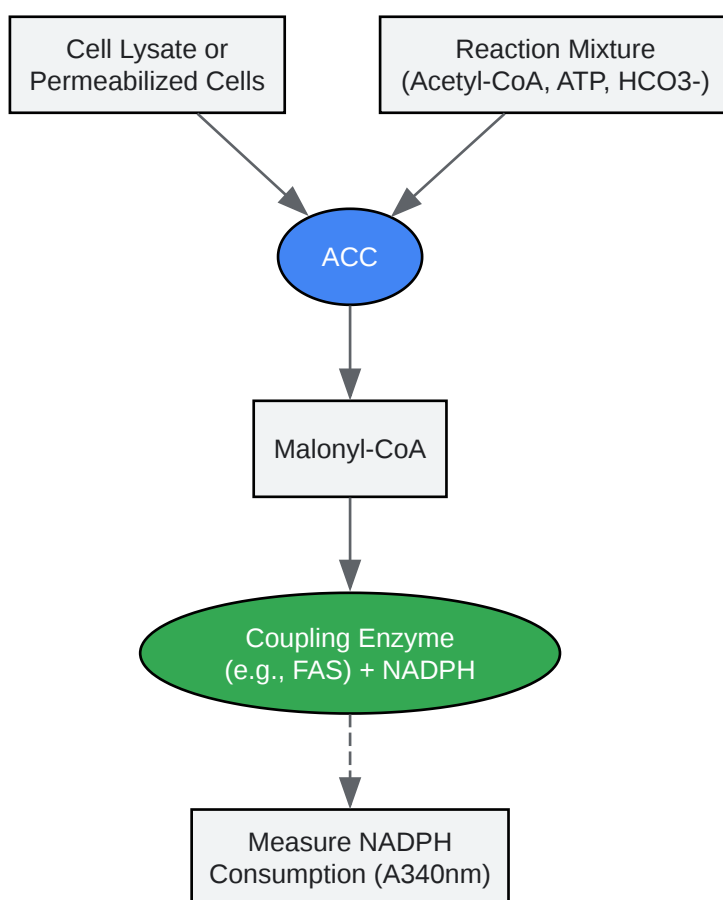

[Click to download full resolution via product page](#)

Fig. 7: Coupled enzyme assay for ACC activity.

Carnitine Palmitoyltransferase 1 (CPT1) Inhibition Assay

Principle: The inhibitory effect of Malonyl-CoA on CPT1 activity is assessed by measuring the rate of acylcarnitine formation from radiolabeled carnitine and a long-chain fatty acyl-CoA in the

presence of varying concentrations of Malonyl-CoA.

Methodology:

- **Mitochondrial Isolation:** Mitochondria are isolated from the tissue of interest by differential centrifugation.
- **Reaction Incubation:** Isolated mitochondria are incubated in a reaction buffer containing a fatty acyl-CoA substrate (e.g., palmitoyl-CoA), radiolabeled L-[³H]carnitine, and varying concentrations of Malonyl-CoA.
- **Separation of Substrate and Product:** The reaction is stopped, and the radiolabeled acylcarnitine product is separated from the unreacted radiolabeled carnitine, often using an ion-exchange resin.
- **Quantification:** The radioactivity of the eluted acylcarnitine is measured by liquid scintillation counting.
- **Data Analysis:** The rate of acylcarnitine formation is plotted against the concentration of Malonyl-CoA to determine the IC₅₀ value (the concentration of Malonyl-CoA that causes 50% inhibition of CPT1 activity).[14]

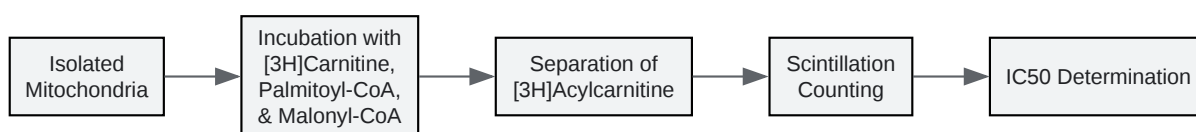

[Click to download full resolution via product page](#)

Fig. 8: Workflow for determining CPT1 inhibition by Malonyl-CoA.

Conclusion and Future Directions

Malonyl-CoA is a linchpin in cellular metabolism, elegantly balancing the synthesis and oxidation of fatty acids. Its role extends beyond that of a simple metabolite, acting as a crucial signaling molecule that integrates nutritional cues with fundamental cellular processes such as growth and appetite regulation. The dysregulation of Malonyl-CoA metabolism is implicated in a range of metabolic disorders, including obesity, type 2 diabetes, and non-alcoholic fatty liver

disease, making the enzymes that control its levels attractive targets for therapeutic intervention.

Future research will likely focus on further elucidating the tissue-specific roles of Malonyl-CoA and the intricate regulatory networks that govern its function. The development of novel pharmacological agents that can selectively modulate the activity of ACC, MCD, and CPT1 holds great promise for the treatment of metabolic diseases. A deeper understanding of the interplay between Malonyl-CoA and major signaling hubs like AMPK and mTORC1 will undoubtedly open new avenues for therapeutic strategies targeting a wide array of human diseases.

Need Custom Synthesis?

BenchChem offers custom synthesis for rare earth carbides and specific isotopic labeling.

Email: info@benchchem.com or [Request Quote Online](#).

References

- 1. Minireview: malonyl CoA, AMP-activated protein kinase, and adiposity - PubMed [pubmed.ncbi.nlm.nih.gov]
- 2. Malonyl-CoA links lipid metabolism to nutrient signalling by directly inhibiting mTORC1 - PubMed [pubmed.ncbi.nlm.nih.gov]
- 3. Malonyl-CoA and AMP-activated protein kinase: an expanding partnership - PubMed [pubmed.ncbi.nlm.nih.gov]
- 4. biorxiv.org [biorxiv.org]
- 5. biorxiv.org [biorxiv.org]
- 6. Hypothalamic malonyl-CoA and the control of food intake - PubMed [pubmed.ncbi.nlm.nih.gov]
- 7. Malonyl-CoA inhibition of carnitine palmitoyltransferase: interpretation of I50 and K1 values - PMC [pmc.ncbi.nlm.nih.gov]
- 8. researchgate.net [researchgate.net]
- 9. Quantification of malonyl-coenzyme A in tissue specimens by high-performance liquid chromatography/mass spectrometry - PubMed [pubmed.ncbi.nlm.nih.gov]
- 10. researchgate.net [researchgate.net]

- 11. pnas.org [pnas.org]
- 12. Regulation of acetyl-coA carboxylase: properties of coA activation of acetyl-coA carboxylase - PMC [pmc.ncbi.nlm.nih.gov]
- 13. Malonyl CoA inhibition of carnitine palmyltransferase in rat heart mitochondria - PubMed [pubmed.ncbi.nlm.nih.gov]
- 14. researchgate.net [researchgate.net]
- 15. Identification of a novel malonyl-CoA IC50 for CPT-1: implications for predicting in vivo fatty acid oxidation rates - PMC [pmc.ncbi.nlm.nih.gov]
- 16. Malonyl-CoA: the regulator of fatty acid synthesis and oxidation - PMC [pmc.ncbi.nlm.nih.gov]
- 17. Malonyl-CoA is a conserved endogenous ATP-competitive mTORC1 inhibitor - PubMed [pubmed.ncbi.nlm.nih.gov]
- 18. Hypothalamic malonyl-CoA and the control of food intake - PMC [pmc.ncbi.nlm.nih.gov]
- 19. A role for the malonyl-CoA/long-chain acyl-CoA pathway of lipid signaling in the regulation of insulin secretion in response to both fuel and nonfuel stimuli - PubMed [pubmed.ncbi.nlm.nih.gov]
- 20. diabetesjournals.org [diabetesjournals.org]
- 21. dspace.library.uu.nl [dspace.library.uu.nl]
- 22. A spectrophotometric assay for measuring acetyl-coenzyme A carboxylase - PubMed [pubmed.ncbi.nlm.nih.gov]
- To cite this document: BenchChem. [The Pivotal Role of Malonyl-CoA in Cellular Metabolism: A Technical Guide]. BenchChem, [2025]. [Online PDF]. Available at: [https://www.benchchem.com/product/b1194419#what-is-the-primary-function-of-malonyl-coa-in-the-cell]

Disclaimer & Data Validity:

The information provided in this document is for Research Use Only (RUO) and is strictly not intended for diagnostic or therapeutic procedures. While BenchChem strives to provide accurate protocols, we make no warranties, express or implied, regarding the fitness of this product for every specific experimental setup.

Technical Support: The protocols provided are for reference purposes. Unsure if this reagent suits your experiment? [[Contact our Ph.D. Support Team for a compatibility check](#)]

Need Industrial/Bulk Grade? [Request Custom Synthesis Quote](#)

BenchChem

Our mission is to be the trusted global source of essential and advanced chemicals, empowering scientists and researchers to drive progress in science and industry.

Contact

Address: 3281 E Guasti Rd
Ontario, CA 91761, United States
Phone: (601) 213-4426
Email: info@benchchem.com