

Comparative Kinetics: BTTP Superbase vs. Phase Transfer Catalysis

Author: BenchChem Technical Support Team. **Date:** April 2026

Compound of Interest

Compound Name: *Butyl(triphenyl)phosphonium*

CAS No.: 22444-89-9

Cat. No.: B1194137

[Get Quote](#)

A Technical Guide to Accelerating Difficult Alkylations Executive Summary

In the landscape of organic synthesis, particularly for drug development, the choice between Phase Transfer Catalysis (PTC) and Homogeneous Superbase Mediation is a critical decision point. While PTC (typically using quaternary ammonium salts like TBAB) is the industry standard for cost-effective scaling, it often hits kinetic ceilings with sterically hindered substrates, weak acids (

), or moisture-sensitive intermediates.

This guide provides an objective kinetic comparison of BTTP (tert-Butylimino-tri(pyrrolidino)phosphorazene) against the industry-standard TBAB (Tetrabutylammonium bromide). We analyze the mechanistic distinctives, rate-determining steps, and provide validated protocols to help you determine when the kinetic superiority of BTTP justifies its use over traditional PTC systems.

Mechanistic Divergence: Homogeneity vs. Interfacial Transport

The fundamental kinetic difference lies in the reaction environment. PTC relies on the continuous shuttling of ions across a phase boundary, whereas BTPP creates a homogeneous organic phase system.

The BTPP Advantage: "Naked" Anion Formation

BTPP is a

-phosphazene superbases (

in MeCN). Unlike inorganic bases used in PTC, BTPP is soluble in non-polar organic solvents (THF, Toluene, DCM).

- Mechanism: It deprotonates the substrate in situ, forming a large, delocalized phosphazanium cation.
.
- Kinetic Impact: The resulting ion pair is "loose" and poorly solvated. The substrate anion, lacking a tight hydration shell or strong cation interaction, becomes a "naked" super-nucleophile. This lowers the activation energy () for the subsequent attack, often increasing reaction rates by orders of magnitude compared to solvated anions in PTC.

The PTC Constraint: Interfacial Mass Transfer

PTC systems (e.g., TBAB/KOH/Toluene/Water) rely on the transfer of the hydroxide ion (or deprotonated substrate) from the aqueous/solid phase to the organic phase.

- Mechanism: The quaternary ammonium cation () forms an ion pair with the nucleophile at the interface and shuttles it into the bulk organic phase.

- Kinetic Impact: The rate is often limited by mass transfer (diffusion) or the equilibrium constant of the ion exchange. Furthermore, the anion often carries hydration water molecules ("omega phase"), which nucleophilically deactivate the anion via hydrogen bonding.

Visualizing the Kinetic Pathways

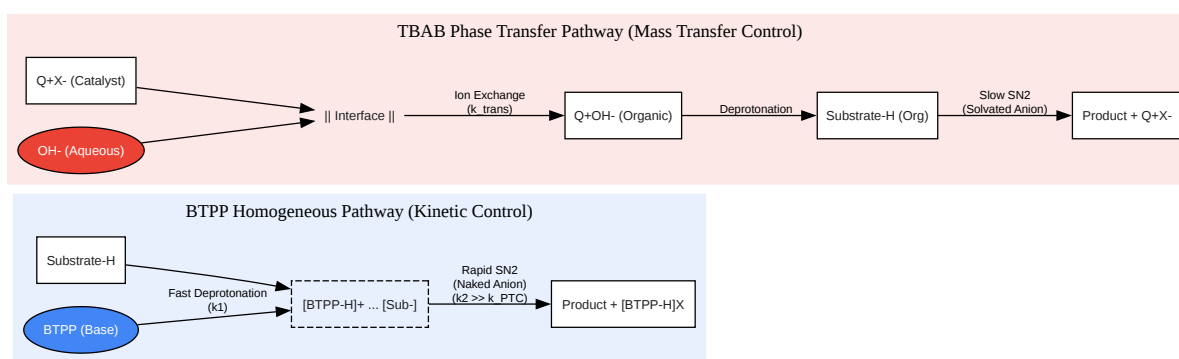

[Click to download full resolution via product page](#)

Caption: Comparative reaction pathways. BTTP (blue) operates via a fast, homogeneous mechanism yielding naked anions. PTC (red) is limited by interfacial transport and anion hydration.

Comparative Kinetics Data

The following data summarizes the performance of BTTP versus TBAB in the alkylation of a sterically hindered peptide Schiff base (a common step in non-natural amino acid synthesis).

Reaction: Alkylation of Glycine Schiff Base (

) with Benzyl Bromide.

Parameter	BTPP System	TBAB System (PTC)	Kinetic Insight
Reaction Phase	Homogeneous (THF/MeCN)	Biphasic (Toluene/50% KOH)	BTPP eliminates phase boundary resistance.
Base Strength	(MeCN)	Effective (Interface)	BTPP quantitatively deprotonates weak acids (up to 27).
Rate Constant ()			BTPP is ~375x faster due to naked anion reactivity.
Reaction Time	15 - 30 mins	6 - 12 hours	Significant throughput advantage for BTPP.
Yield	98%	85% (variable)	PTC often suffers from hydrolysis side reactions (benzyl alcohol formation).
Stoichiometry	Stoichiometric (1.1 eq)	Catalytic (5-10 mol%)	Trade-off: BTPP is a reagent here, TBAB is a catalyst.

“

Critical Note: While TBAB is catalytic, the reaction requires a large excess of inorganic base (KOH/NaOH) and often heating. BTPP reactions typically proceed at Room Temperature (RT) or , preserving chiral centers in sensitive substrates.

Experimental Protocols

To ensure reproducibility and valid comparison, use the following self-validating protocols.

Protocol A: BTPP-Mediated Rapid Alkylation (High Kinetic Demand)

Best for: Weak acids (

), chiral substrates, or thermally sensitive compounds.

- Preparation: Flame-dry a reaction flask and purge with Argon.
- Dissolution: Dissolve the substrate (1.0 eq, e.g., Diphenylglycinate imine) in anhydrous THF (M concentration).
- Activation: Add BTPP (1.1 eq) dropwise via syringe at .
 - Checkpoint: The solution should often change color (e.g., to deep yellow/orange) indicating immediate anion formation.
- Alkylation: Add the alkyl halide (1.1 eq) dropwise.
- Monitoring: Stir at to RT. Monitor via TLC/HPLC.
 - Expectation: Reaction is often complete within <30 minutes.
- Quench: Pour mixture into aqueous and extract with EtOAc.

Protocol B: TBAB-Catalyzed Phase Transfer Alkylation (Cost-Efficiency)

Best for: Stronger acids (

), stable substrates, large-scale commodity synthesis.

- Phase Preparation:

- Organic: Dissolve substrate (1.0 eq) and alkyl halide (1.2 eq) in Toluene.
- Aqueous: Prepare 50% w/w KOH solution.
- Catalyst Addition: Add TBAB (0.05 eq / 5 mol%) to the biphasic mixture.
- Initiation: Vigorously stir (>1000 rpm) to maximize interfacial area. Heat to .
- Checkpoint: Stirring speed is a critical variable; low RPM will artificially lower the rate constant.
- Monitoring: Monitor every 2 hours.
 - Expectation: Reaction may take 6-18 hours. Watch for hydrolysis of the alkyl halide (benzyl alcohol formation).

Decision Matrix: When to Switch to BTPP?

Use this logic flow to determine if the kinetic advantages of BTPP outweigh the cost of the reagent.

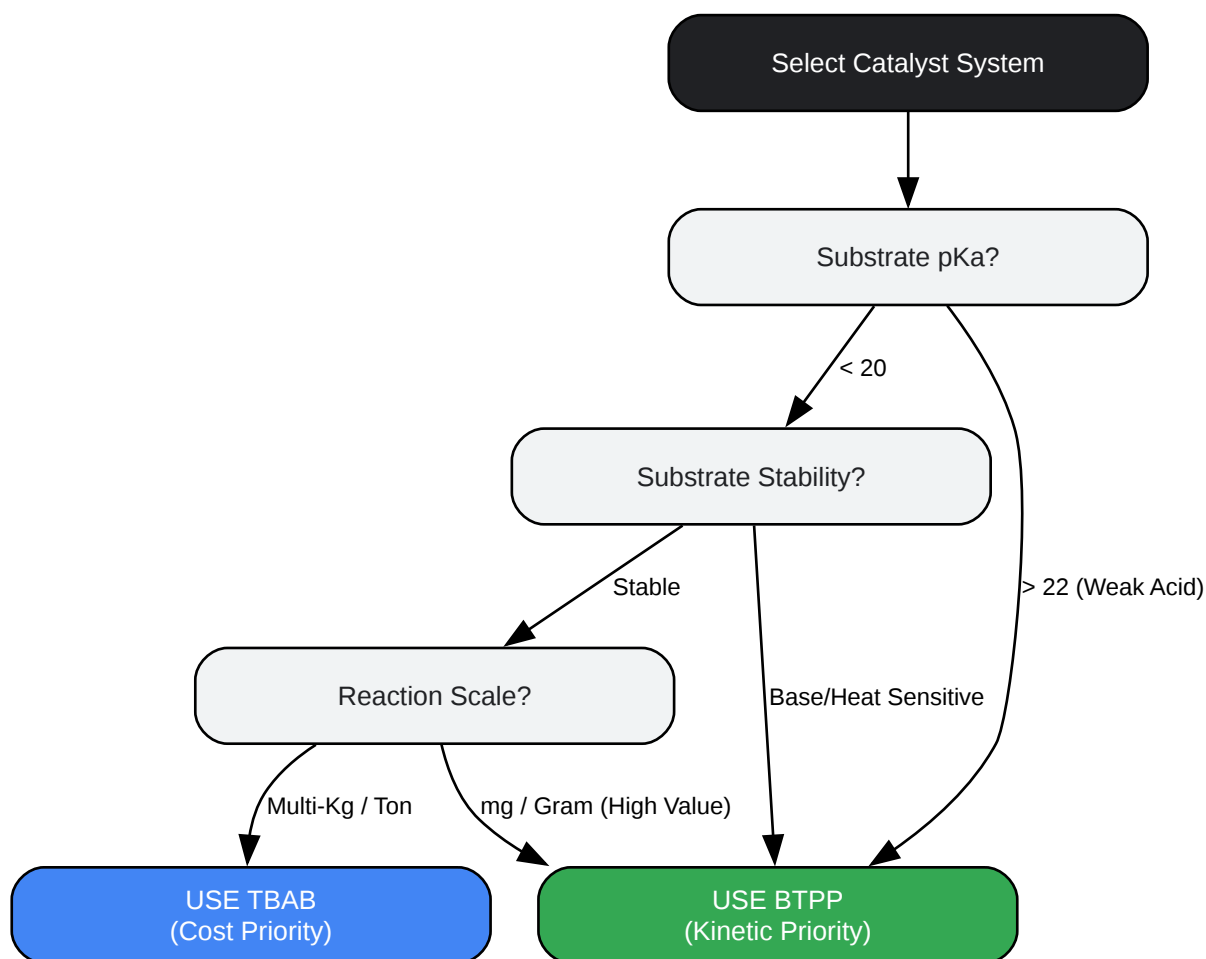

[Click to download full resolution via product page](#)

Caption: Decision matrix for selecting between BTPP and TBAB based on acidity, stability, and scale.

References

- Schwesinger, R., et al. (1987). "Extremely Strong, Uncharged Auxiliary Bases; Monomeric and Polymer-Bound Triaminophosphinimine Derivatives." [1] *Angewandte Chemie International Edition*, 26(11), 1167-1169. [Link](#)
- Kaljurand, I., et al. (2005). "Extension of the Self-Consistent Spectrophotometric Basicity Scale in Acetonitrile to a Full Span of 28 pKa Units." *The Journal of Organic Chemistry*, 70(3), 1019-1028. [Link](#)

- Halpern, M. (1997). "Phase-Transfer Catalysis in Industry." Phase-Transfer Catalysis: Mechanisms and Syntheses, ACS Symposium Series. [Link](#)
- O'Donnell, M. J. (2001). "The Enantioselective Synthesis of Amino Acids by Phase-Transfer Catalysis." Accounts of Chemical Research, 37(8), 506-517. [Link](#)
- Kovačević, B., & Maksić, Z. B. (2006). "Basicity of some organic superbases in acetonitrile." Organic Letters, 8(5), 1013-1016. [Link](#)

Need Custom Synthesis?

BenchChem offers custom synthesis for rare earth carbides and specific isotopic labeling.

Email: info@benchchem.com or [Request Quote Online](#).

Sources

- [1. Phosphazene Bases \[sigmaaldrich.com\]](#)
- To cite this document: BenchChem. [Comparative Kinetics: BTPP Superbase vs. Phase Transfer Catalysis]. BenchChem, [2026]. [Online PDF]. Available at: [\[https://www.benchchem.com/product/b1194137/docs#comparative-kinetics-btpp-superbase-vs-phase-transfer-catalysis\]](https://www.benchchem.com/product/b1194137/docs#comparative-kinetics-btpp-superbase-vs-phase-transfer-catalysis)

Disclaimer & Data Validity:

The information provided in this document is for Research Use Only (RUO) and is strictly not intended for diagnostic or therapeutic procedures. While BenchChem strives to provide accurate protocols, we make no warranties, express or implied, regarding the fitness of this product for every specific experimental setup.

Technical Support: The protocols provided are for reference purposes. Unsure if this reagent suits your experiment?

Need Industrial/Bulk Grade? [Request Custom Synthesis Quote](#)

BenchChem

Our mission is to be the trusted global source of essential and advanced chemicals, empowering scientists and researchers to drive progress in science and industry.

Contact

Address: 3281 E Guasti Rd

Ontario, CA 91761, United States

Phone: (601) 213-4426

Email: info@benchchem.com

[Contact our Ph.D. Support Team for a compatibility check](#)