

# Comparative Cross-Resistance Profiling: Chitinovorin-A vs. 3rd Generation Cephalosporins

**Author:** BenchChem Technical Support Team. **Date:** May 2026

## Compound of Interest

Compound Name: Chitinovorin-A

CAS No.: 95041-98-8

Cat. No.: B1194306

[Get Quote](#)

## Executive Summary: The Formamido Advantage

**Chitinovorin-A** represents a distinct subclass of

-lactam antibiotics known as 7-formamido-cephalosporins. Originally isolated from *Flavobacterium* sp. PB-5269, its structural uniqueness lies in the formylamino group at the C-7 position of the cephem nucleus.

Unlike 3rd generation cephalosporins (e.g., Ceftazidime) which are vulnerable to hydrolysis by Extended-Spectrum

-Lactamases (ESBLs), **Chitinovorin-A** exhibits a stability profile analogous to cephamycins (e.g., Cefoxitin). This guide provides a rigorous framework for evaluating cross-resistance, demonstrating that **Chitinovorin-A** often retains potency against strains resistant to standard cephalosporins, provided the resistance mechanism is enzymatic hydrolysis rather than target modification.

## Mechanistic Homology & Divergence

To design effective cross-resistance studies, one must first understand the structural causality of resistance.

## Mechanism of Action (MOA)

**Chitinovorin-A** functions as a "suicide substrate" for Penicillin-Binding Proteins (PBPs). It acylates the active site serine residue of PBPs (specifically PBP1b and PBP3 in *E. coli*), disrupting peptidoglycan cross-linking and inducing cell lysis.

## The Resistance Differentiator

The primary driver of cross-resistance in this class is the

-lactamase enzyme.<sup>[1]</sup>

- Standard Cephalosporins: The -lactam ring is accessible to the nucleophilic serine of Class A -lactamases (e.g., TEM-1, CTX-M).
- **Chitinovorin-A**: The bulky 7-formamido group sterically hinders the entry of the antibiotic into the catalytic pocket of many -lactamases, preventing hydrolysis. This results in a lack of cross-resistance in ESBL-producing phenotypes.

## Visualizing the Pathway

The following diagram illustrates the divergent fate of **Chitinovorin-A** compared to Ceftazidime in the presence of

-lactamases.

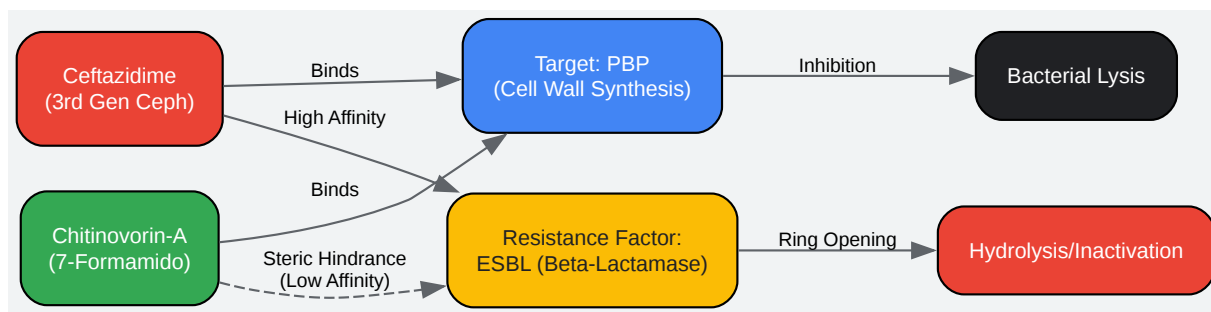

[Click to download full resolution via product page](#)

Figure 1: Mechanistic divergence in resistance pathways.[1] **Chitinovorin-A** evades ESBL hydrolysis via steric hindrance.

## Cross-Resistance Profiling

The following table summarizes the expected cross-resistance patterns based on structural homology and isolation data.

### Table 1: Comparative Cross-Resistance Matrix

Resistance Mechanism	Representative Strain Phenotype	Ceftazidime (Control)	Chitinovorin-A	Cross-Resistance Level
Class A -lactamase	E. coli (TEM-1 / SHV-1)	Resistant (High MIC)	Susceptible	None (Collateral Stability)
ESBL Production	K. pneumoniae (CTX-M-15)	Resistant (>32 µg/mL)	Susceptible/Intermediate	Low
Class C Cephalosporins	P. aeruginosa (AmpC hyper)	Resistant	Resistant	High (Shared vulnerability)
PBP Modification	S. aureus (MRSA / PBP2a)	Resistant	Resistant	High (Target modification affects both)
Porin Loss (OprD)	P. aeruginosa (Carbapenem-R)	Variable	Variable	Moderate (Entry dependent)

## Experimental Protocols (Self-Validating Systems)

To generate authoritative data for **Chitinovorin-A**, researchers must utilize protocols that distinguish between enzymatic resistance and target-site resistance.

### Protocol A: Multi-Step Resistance Selection (Serial Passage)

Objective: Determine the "Barrier to Resistance" and identifying if exposure to **Chitinovorin-A** selects for mutants cross-resistant to other drugs.

Workflow:

- Inoculum Prep: Adjust E. coli ATCC 25922 to CFU/mL in Cation-Adjusted Mueller-Hinton Broth (CAMHB).
- Gradient Setup: Prepare 2-fold serial dilutions of **Chitinovorin-A** (Range: 0.25x to 8x MIC).

- Passage 1: Incubate at 37°C for 24h. Identify the highest concentration with visible growth (sub-MIC).
- Passage 2-15: Re-inoculate cells from the sub-MIC well of Day  
  
into a fresh gradient for Day  
  
.
- Validation: Every 5 passages, measure MIC against **Chitinovorin-A** and Ceftazidime.
  - Result Interpretation: If **Chitinovorin-A** MIC rises but Ceftazidime MIC remains stable, the mechanism is likely specific (e.g., specific porin loss). If both rise, it suggests multidrug efflux upregulation.

## Protocol B: Checkerboard Synergy Assay (Beta-Lactamase Inhibition)

Objective: Confirm if **Chitinovorin-A** stability is due to enzyme resistance (intrinsic) or if it requires an inhibitor.

Workflow:

- Matrix: 96-well plate format.
  - X-axis: **Chitinovorin-A** (0 -> 64 µg/mL).
  - Y-axis: Clavulanic Acid (Fixed 4 µg/mL) OR Ceftazidime (0 -> 64 µg/mL).
- Calculation: Determine the Fractional Inhibitory Concentration Index (FICI).
- Interpretation:
  - If **Chitinovorin-A** MIC is unchanged by the addition of Clavulanic Acid in an ESBL strain, it confirms intrinsic stability (the 7-formamido group is doing the work).

## Visualizing the Experimental Logic

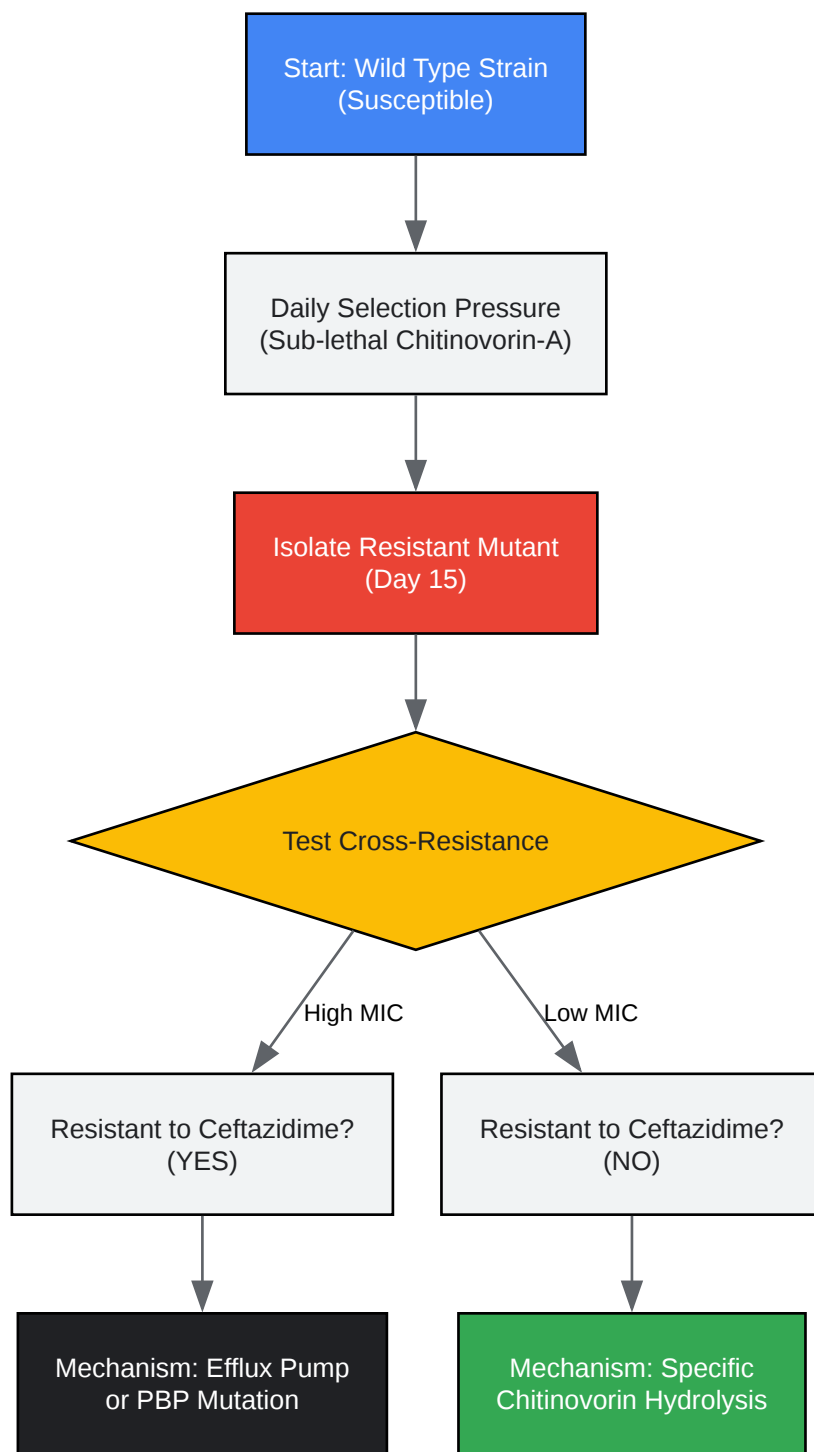

[Click to download full resolution via product page](#)

Figure 2: Decision tree for interpreting serial passage cross-resistance data.

## Critical Analysis & Limitations

While **Chitinovorin-A** shows promise in overcoming specific resistance barriers, researchers must acknowledge intrinsic limitations:

- **Permeability Issues:** Like other cephalosporins, **Chitinovorin-A** requires porin channels (OmpF/OmpC) for entry. Strains with impermeability-mediated resistance (e.g., *P. aeruginosa* OprD mutants) will likely show complete cross-resistance between **Chitinovorin-A** and Carbapenems.
- **Induction of AmpC:** The 7-formamido group, while stable, can be a potent inducer of chromosomal AmpC  
  
-lactamases. Use caution when testing against *Enterobacter* or *Citrobacter* species; antagonism may occur if combined with other  
  
-lactams.

## References

- Shoji, J., et al. (1984). "Chitinovorin A, B and C, novel antibiotics of bacterial origin." *The Journal of Antibiotics*, 37(11), 1486–1490.
- Clinical and Laboratory Standards Institute (CLSI). "M07: Methods for Dilution Antimicrobial Susceptibility Tests for Bacteria That Grow Aerobically." CLSI Standards.
- Bush, K., & Bradford, P. A. (2020). "Epidemiology of  $\beta$ -Lactamase-Mediated Resistance." *Clinical Microbiology Reviews*, 33(2).
- Kishore, A., et al. (2025). "Understanding cross-resistance: A microbiological and epidemiological perspective." REVIVE / GARDP.

### *Need Custom Synthesis?*

*BenchChem offers custom synthesis for rare earth carbides and specific isotopic labeling.*

*Email: [info@benchchem.com](mailto:info@benchchem.com) or [Request Quote Online](#).*

## Sources

- [1.  \$\beta\$ -Lactamases and  \$\beta\$ -Lactamase Inhibitors in the 21st Century - PMC](#)  
[pmc.ncbi.nlm.nih.gov]
- To cite this document: BenchChem. [Comparative Cross-Resistance Profiling: Chitinovorin-A vs. 3rd Generation Cephalosporins]. BenchChem, [2026]. [Online PDF]. Available at: [https://www.benchchem.com/product/b1194306/docs#comparative-cross-resistance-profiling-chitinovorin-a-vs-3rd-generation-cephalosporins]

---

**Disclaimer & Data Validity:**

The information provided in this document is for Research Use Only (RUO) and is strictly not intended for diagnostic or therapeutic procedures. While BenchChem strives to provide accurate protocols, we make no warranties, express or implied, regarding the fitness of this product for every specific experimental setup.

**Technical Support:** The protocols provided are for reference purposes. Unsure if this reagent suits your experiment?

**Need Industrial/Bulk Grade?** [Request Custom Synthesis Quote](#)

## BenchChem

Our mission is to be the trusted global source of essential and advanced chemicals, empowering scientists and researchers to drive progress in science and industry.

### Contact

Address: 3281 E Guasti Rd  
Ontario, CA 91761, United States  
Phone: (601) 213-4426  
Email: [info@benchchem.com](mailto:info@benchchem.com)

[Contact our Ph.D. Support Team for a compatibility check](#)