

Carbodine vs. Amantadine: A Comparative Guide to In Vitro Antiviral Potency

Author: BenchChem Technical Support Team. **Date:** December 2025

Compound of Interest

Compound Name: Carbodine

Cat. No.: B1194034

[Get Quote](#)

For Researchers, Scientists, and Drug Development Professionals

This guide provides a detailed comparison of the in vitro antiviral potency of **Carbodine** and Amantadine, focusing on their mechanisms of action, quantitative potency data, and the experimental protocols used for their evaluation.

Introduction

Carbodine, a carbocyclic nucleoside analog, and Amantadine, an adamantane derivative, represent two distinct classes of antiviral agents. While both have demonstrated activity against influenza A viruses, their mechanisms of action and potency profiles differ significantly. This guide aims to provide an objective comparison based on available experimental data to inform research and drug development efforts.

Mechanism of Action

Carbodine: Inhibition of CTP Synthetase

Carbodine exerts its antiviral effect by targeting a crucial enzyme in the host cell's pyrimidine biosynthesis pathway: CTP (cytidine triphosphate) synthetase.[1] As a carbocyclic analogue of cytidine, **Carbodine** is intracellularly phosphorylated to its triphosphate form.[2] This active metabolite then inhibits CTP synthetase, the enzyme responsible for the conversion of UTP (uridine triphosphate) to CTP.[2] By depleting the intracellular pool of CTP, an essential precursor for RNA synthesis, **Carbodine** effectively inhibits the replication of RNA viruses.

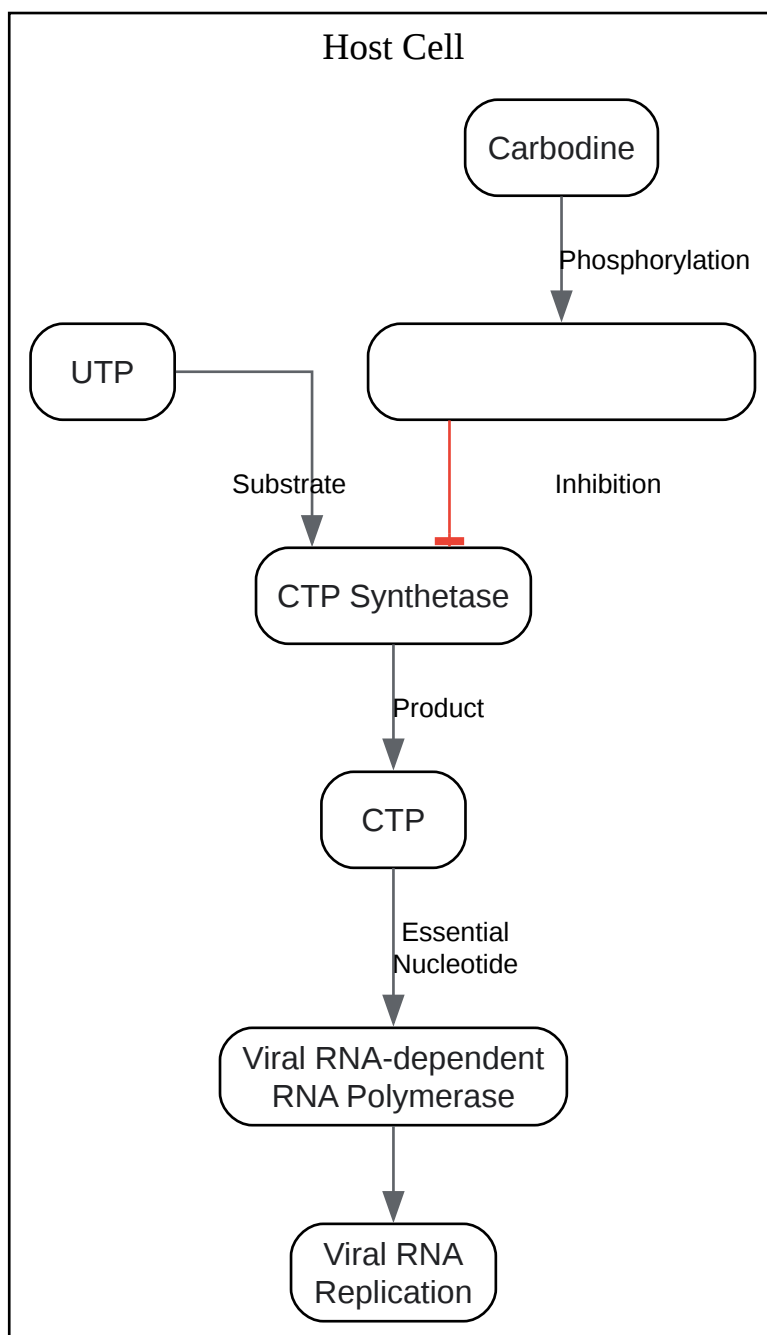

[Click to download full resolution via product page](#)

Carbodine's Mechanism of Action

Amantadine: M2 Proton Channel Blockade

Amantadine's primary antiviral mechanism against influenza A viruses involves the blockade of the viral M2 proton channel.[3][4] After the virus enters the host cell via endocytosis, the acidic

environment of the endosome typically triggers the M2 channel to pump protons into the viral core. This acidification is a critical step for the dissociation of the viral ribonucleoprotein (RNP) complex and its subsequent release into the cytoplasm, a process known as uncoating. By blocking this proton influx, Amantadine prevents viral uncoating and thus halts the replication cycle at an early stage.[5][6]

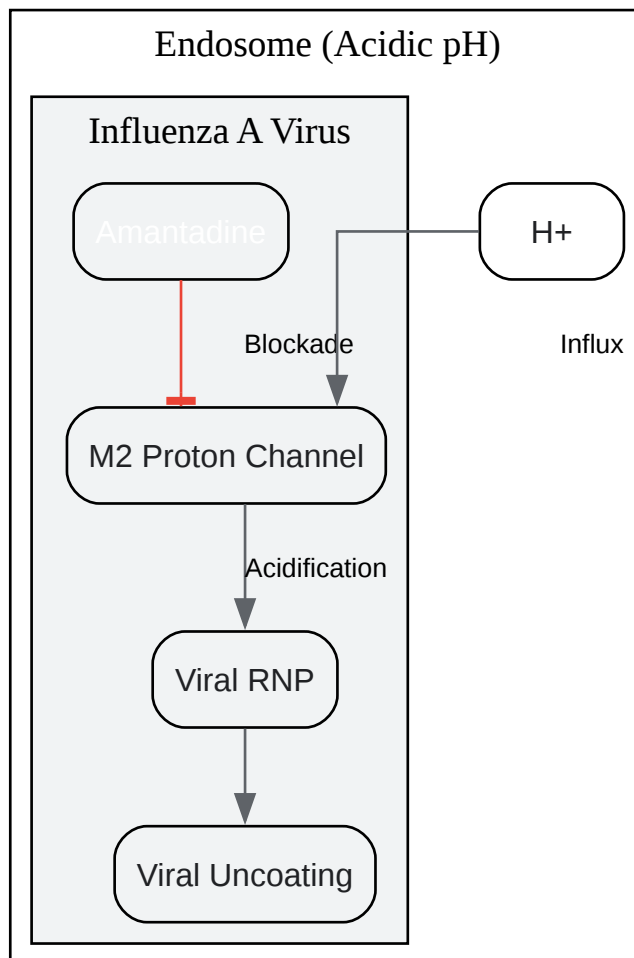

[Click to download full resolution via product page](#)

Amantadine's Mechanism of Action

In Vitro Potency

The following table summarizes the reported in vitro potency of **Carbodine** and Amantadine against influenza A viruses. It is important to note that the values are derived from different

studies using varied experimental conditions (e.g., virus strains, cell lines, and assay methods), and therefore, a direct comparison of the absolute values should be made with caution.

Compound	Virus Strain(s)	Cell Line(s)	Potency Metric	Value (µg/mL)	Reference(s)
Carbodine	Human Influenza A	Not Specified	MIC ₅₀	~2.6	
Influenza A and B strains	Not Specified	-	Potent	[7]	
Amantadine	Influenza A (susceptible strains)	Madin-Darby Canine Kidney (MDCK)	IC ₅₀	0.2 - 0.4	
Influenza A (various strains)	Madin-Darby Canine Kidney (MDCK)	IC ₅₀	0.062 - >50		
Influenza A (H1N1) with resistance mutations	Madin-Darby Bovine Kidney (MDBK)	IC ₅₀	>154x WT	[3]	

Experimental Protocols

The in vitro antiviral potency of these compounds is commonly determined using a Plaque Reduction Assay. This assay quantifies the ability of a drug to inhibit the formation of viral plaques, which are localized areas of cell death caused by viral replication in a cell monolayer.

General Protocol for Plaque Reduction Assay

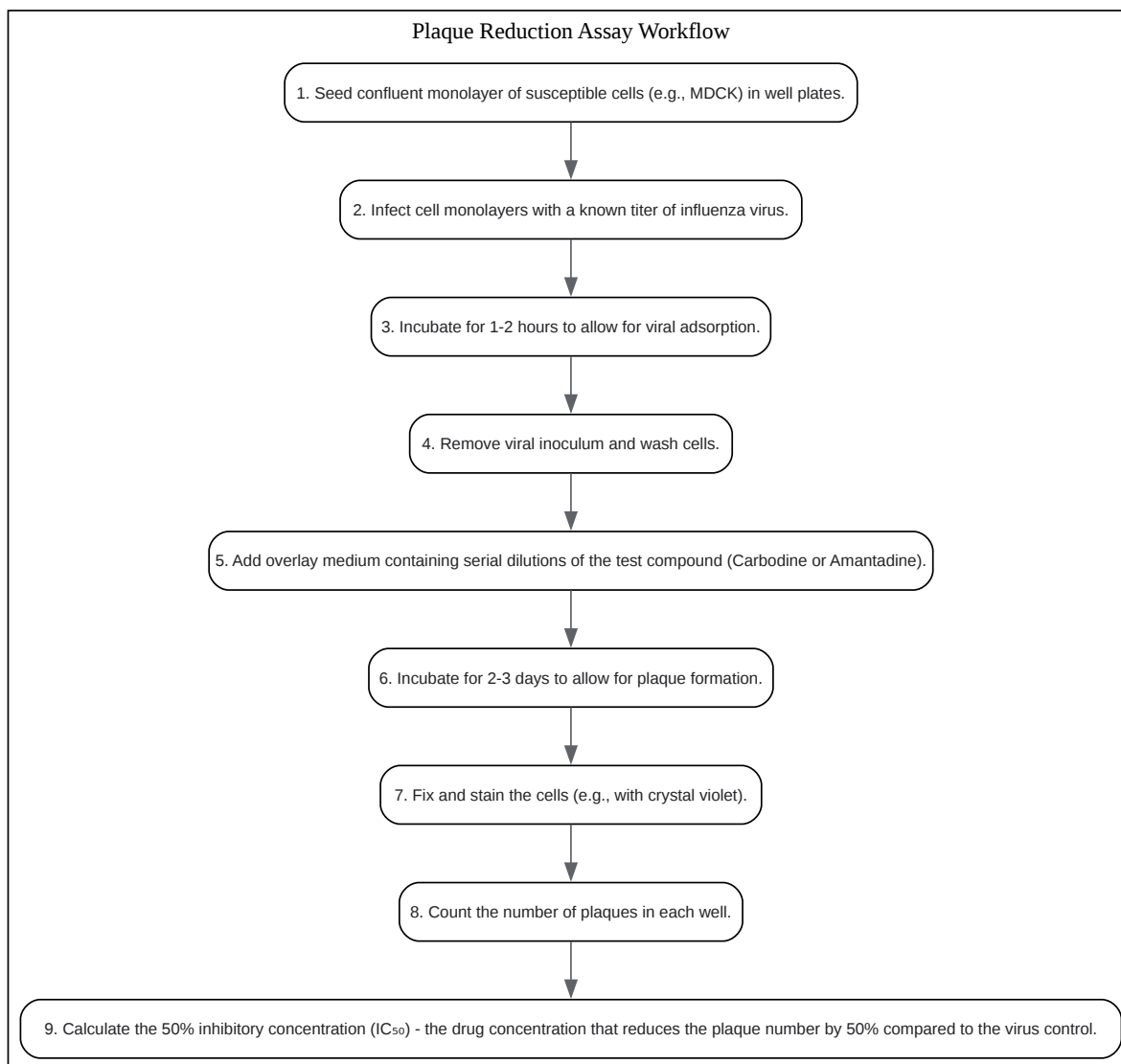

[Click to download full resolution via product page](#)

Plaque Reduction Assay Workflow

Materials and Reagents:

- Susceptible host cells (e.g., Madin-Darby Canine Kidney - MDCK cells)[8][9][10]
- Influenza A virus stock of a known titer
- Cell culture medium (e.g., DMEM)
- Fetal Bovine Serum (FBS)
- Trypsin-EDTA
- Overlay medium (e.g., containing agarose or methylcellulose)
- Test compounds (**Carbodine**, Amantadine)
- Fixing solution (e.g., 10% formalin)
- Staining solution (e.g., 0.1% crystal violet)
- Phosphate Buffered Saline (PBS)

Procedure:

- Cell Seeding: Plate MDCK cells in 6-well or 12-well plates and grow until they form a confluent monolayer.
- Virus Infection: Aspirate the growth medium and infect the cell monolayers with a dilution of influenza virus calculated to produce a countable number of plaques.
- Adsorption: Incubate the plates for 1-2 hours at 37°C to allow the virus to attach to and enter the cells.
- Compound Addition: Remove the virus inoculum and wash the cells with PBS. Add an overlay medium containing various concentrations of **Carbodine** or Amantadine. A virus control (no drug) and a cell control (no virus, no drug) should be included.

- Incubation: Incubate the plates at 37°C in a CO₂ incubator for 48-72 hours, or until visible plaques are formed in the virus control wells.
- Plaque Visualization: Aspirate the overlay medium and fix the cells. After fixation, remove the fixative and stain the cells with crystal violet. Plaques will appear as clear zones against a background of stained, uninfected cells.
- Data Analysis: Count the number of plaques at each drug concentration. The percentage of plaque inhibition is calculated relative to the virus control. The IC₅₀ value is then determined by plotting the percentage of inhibition against the drug concentration and fitting the data to a dose-response curve.[11]

Conclusion

Carbodine and Amantadine represent two different approaches to inhibiting influenza A virus replication. **Carbodine**'s broad-spectrum potential stems from its targeting of a host cell enzyme essential for viral RNA synthesis, while Amantadine's activity is specific to influenza A viruses through its interaction with the viral M2 proton channel. The in vitro potency data, though not directly comparable across all studies, suggests that Amantadine is highly potent against susceptible strains, but its efficacy is severely limited by the prevalence of resistant variants. **Carbodine** shows promise as a broad-spectrum antiviral, and further head-to-head comparative studies with standardized protocols are warranted to fully elucidate its therapeutic potential relative to existing antiviral agents.

Need Custom Synthesis?

BenchChem offers custom synthesis for rare earth carbides and specific isotopic labeling.

Email: info@benchchem.com or [Request Quote Online](#).

References

1. CTP synthetase - Wikipedia [en.wikipedia.org]
2. Cyclopentenylcytosine triphosphate. Formation and inhibition of CTP synthetase - PubMed [pubmed.ncbi.nlm.nih.gov]

- 3. Generation and Characterization of Recombinant Influenza A (H1N1) Viruses Harboring Amantadine Resistance Mutations - PMC [pmc.ncbi.nlm.nih.gov]
- 4. Inhibitors of the Influenza A Virus M2 Proton Channel Discovered Using a High-Throughput Yeast Growth Restoration Assay - PMC [pmc.ncbi.nlm.nih.gov]
- 5. Where does amantadine bind to the influenza virus M2 proton channel? - PMC [pmc.ncbi.nlm.nih.gov]
- 6. Frontiers | Conformational Response of Influenza A M2 Transmembrane Domain to Amantadine Drug Binding at Low pH (pH 5.5) [frontiersin.org]
- 7. (-)-Carbodine: enantiomeric synthesis and in vitro antiviral activity against various strains of influenza virus including H5N1 (avian influenza) and novel 2009 H1N1 (swine flu) - PubMed [pubmed.ncbi.nlm.nih.gov]
- 8. High yields of influenza A virus in Madin-Darby canine kidney cells are promoted by an insufficient interferon-induced antiviral state - PubMed [pubmed.ncbi.nlm.nih.gov]
- 9. Comparative Susceptibility of Madin-Darby Canine Kidney (MDCK) Derived Cell Lines for Isolation of Swine Origin Influenza A Viruses from Different Clinical Specimens - PubMed [pubmed.ncbi.nlm.nih.gov]
- 10. mdpi.com [mdpi.com]
- 11. researchgate.net [researchgate.net]
- To cite this document: BenchChem. [Carbodine vs. Amantadine: A Comparative Guide to In Vitro Antiviral Potency]. BenchChem, [2025]. [Online PDF]. Available at: [https://www.benchchem.com/product/b1194034#carbodine-versus-amantadine-in-vitro-potency]

Disclaimer & Data Validity:

The information provided in this document is for Research Use Only (RUO) and is strictly not intended for diagnostic or therapeutic procedures. While BenchChem strives to provide accurate protocols, we make no warranties, express or implied, regarding the fitness of this product for every specific experimental setup.

Technical Support: The protocols provided are for reference purposes. Unsure if this reagent suits your experiment? [[Contact our Ph.D. Support Team for a compatibility check](#)]

Need Industrial/Bulk Grade? [Request Custom Synthesis Quote](#)

BenchChem

Our mission is to be the trusted global source of essential and advanced chemicals, empowering scientists and researchers to drive progress in science and industry.

Contact

Address: 3281 E Guasti Rd

Ontario, CA 91761, United States

Phone: (601) 213-4426

Email: info@benchchem.com