

# Technical Support Center: Navigating Leelamine Hydrochloride Experiments

**Author:** BenchChem Technical Support Team. **Date:** April 2026

## Compound of Interest

Compound Name: *Leelamine hydrochloride*

Cat. No.: *B11935780*

[Get Quote](#)

This technical support center is designed to assist researchers, scientists, and drug development professionals in addressing challenges and inconsistencies encountered during experiments with **Leelamine hydrochloride**. Below you will find troubleshooting guides, frequently asked questions (FAQs), detailed experimental protocols, and data summaries to facilitate smoother and more reproducible research.

## Frequently Asked Questions (FAQs)

Q1: What is the primary mechanism of action of **Leelamine hydrochloride**?

A1: Leelamine is a natural product derived from pine bark. Its primary anticancer mechanism stems from its lysosomotropic properties. As a weakly basic amine, it accumulates in the acidic environment of lysosomes. This accumulation disrupts intracellular cholesterol transport, leading to cholesterol buildup within lysosomes. The resulting depletion of available cholesterol for cellular processes inhibits key oncogenic signaling pathways, including PI3K/AKT, MAPK, and STAT3, ultimately inducing cancer cell death.<sup>[1][2][3]</sup>

Q2: Why am I seeing inconsistent results between different batches of my **Leelamine hydrochloride** experiments?

A2: Inconsistent results with **Leelamine hydrochloride** can arise from several factors. Compound solubility and stability are critical; ensure the compound is fully dissolved in your stock solution (e.g., DMSO) and does not precipitate upon dilution into aqueous assay buffers. It is also important to check for compound degradation over time and with repeated freeze-thaw cycles. For in vivo studies, inconsistencies can be due to inaccurate dosing, variations in tumor size at the start of treatment, or instability of the leelamine formulation.

Q3: My **Leelamine hydrochloride** solution appears cloudy or forms a precipitate. What should I do?

A3: **Leelamine hydrochloride** can have limited aqueous solubility. If you observe cloudiness or precipitation, ensure your stock solution in an organic solvent like DMSO is fully dissolved before further dilution. When preparing formulations for in vivo studies, it is crucial to follow the recommended vehicle composition and preparation steps precisely to maintain solubility. For instance, a common vehicle involves a mixture of ethanol, DMSO, Kolliphor EL, and PBS. Always prepare fresh dosing solutions before each administration.

Q4: At what concentration should I use **Leelamine hydrochloride** in my cell-based assays?

A4: The optimal concentration of **Leelamine hydrochloride** will vary depending on the cell line and the specific assay. It is recommended to perform a dose-response experiment to determine the IC<sub>50</sub> value for your specific cell line. Based on published data, IC<sub>50</sub> values for melanoma cell lines typically range from 1.8  $\mu\text{M}$  to 4.0  $\mu\text{M}$ .

Q5: Can **Leelamine hydrochloride** interfere with the MTT assay?

A5: It is possible for compounds to interfere with the MTT assay. To rule this out, you can perform a cell-free control experiment. Prepare a 96-well plate with your culture medium and the same concentrations of **Leelamine hydrochloride** used in your cell-based assay, but without cells. Add the MTT reagent and solubilization solution as you would in your experiment. If you observe a significant color change in the absence of cells, it indicates that **Leelamine hydrochloride** is directly reducing the MTT reagent. In such cases, consider using an alternative cell viability assay like the lactate dehydrogenase (LDH) assay.

## Troubleshooting Guides

## In Vitro Assay Troubleshooting

Problem	Potential Cause(s)	Recommended Solution(s)
High variability between replicate wells in MTT assay	- Uneven cell seeding- Pipetting errors- Incomplete formazan crystal dissolution	- Ensure the cell suspension is homogeneous before and during plating.- Calibrate pipettes regularly and use a multi-channel pipette for reagent addition.- Visually confirm complete dissolution of formazan crystals before reading the plate. Gentle agitation can help. <a href="#">[4]</a> <a href="#">[5]</a> <a href="#">[6]</a> <a href="#">[7]</a>
No or weak signal in Western blot for phosphorylated proteins	- Inactive primary or secondary antibody- Insufficient protein loading- Inefficient protein transfer	- Use fresh antibody dilutions and ensure proper storage.- Increase the amount of protein loaded onto the gel.- Verify transfer efficiency using Ponceau S staining. <a href="#">[8]</a> <a href="#">[9]</a> <a href="#">[10]</a> <a href="#">[11]</a> <a href="#">[12]</a>
High background in Western blot	- Blocking insufficient- Antibody concentration too high- Inadequate washing	- Optimize blocking conditions (e.g., 5% BSA or non-fat milk in TBST).- Titrate primary and secondary antibody concentrations.- Increase the number and duration of wash steps. <a href="#">[8]</a> <a href="#">[9]</a> <a href="#">[10]</a> <a href="#">[11]</a> <a href="#">[12]</a>
False positives in Annexin V/PI flow cytometry	- Mechanical cell damage during harvesting- Spontaneous apoptosis in control cells- Improper compensation settings	- Handle cells gently; avoid harsh pipetting.- Use healthy, log-phase cells and avoid over-confluency.- Run single-stain controls to set proper compensation. <a href="#">[13]</a> <a href="#">[14]</a> <a href="#">[15]</a>

## In Vivo Experiment Troubleshooting

Problem	Potential Cause(s)	Recommended Solution(s)
Inconsistent tumor growth inhibition	- Inaccurate dosing- Variation in initial tumor size- Instability of Leelamine formulation	- Ensure precise dose calculation based on individual animal weight.- Randomize animals into groups after tumors have reached a consistent size.- Prepare fresh dosing solution for each administration and ensure complete dissolution.
Signs of toxicity (e.g., weight loss)	- Dosage too high for the specific animal strain- Formulation-related toxicity	- Start with a lower dose and escalate gradually.- Include a vehicle-only control group to assess the toxicity of the formulation components.
Suboptimal tumor growth inhibition	- Dosage too low- Inappropriate route of administration	- Gradually increase the dose within the reported effective range.- Consider the bioavailability of different administration routes for your specific model.

## Data Presentation

Table 1: Anti-proliferative Activity of Leelamine and its Derivatives in Melanoma Cell Lines

Compound	Derivative Type	Modification	IC50 (μM) in UACC 903	IC50 (μM) in 1205 Lu
Leelamine	Parent Compound	-	~1.8	~2.2
5a	Leelamine Derivative	Amidation of the primary amine with a trifluoroacetyl group	1.2	2.0
5b	Leelamine Derivative	Amidation of the primary amine with a tribromoacetyl group	1.0	1.8
5c	Leelamine Derivative	Amidation of the primary amine with a bulkier group	> 10	> 10
Abietic Acid	Structural Analog	Carboxylic acid instead of amine	Inactive	Inactive
4a	Abietic Acid Derivative	Replacement of carboxylic acid with an amino group	~2.5	~3.0

Data summarized from Gowda et al., "Identifying the structure-activity relationship of leelamine necessary for inhibiting intracellular cholesterol transport," *Oncotarget* (2017).[10]

## Experimental Protocols

### MTT Cell Viability Assay

- Cell Seeding: Seed cells in a 96-well plate at a predetermined optimal density and allow them to attach overnight.

- **Compound Treatment:** Treat cells with serial dilutions of **Leelamine hydrochloride** and a vehicle control (e.g., DMSO). Incubate for the desired period (e.g., 24, 48, or 72 hours).
- **MTT Addition:** Add MTT solution (final concentration 0.5 mg/mL) to each well and incubate for 2-4 hours at 37°C to allow for the formation of formazan crystals.
- **Solubilization:** Carefully remove the MTT solution and add a solubilization solution (e.g., DMSO) to each well to dissolve the formazan crystals.
- **Absorbance Measurement:** Measure the absorbance at a wavelength between 550 and 600 nm using a microplate reader.

## Western Blot for PI3K/AKT, MAPK, and STAT3 Pathway Inhibition

- **Cell Treatment:** Plate cells and allow them to adhere overnight. Treat with varying concentrations of **Leelamine hydrochloride** (e.g., 3 to 6  $\mu\text{mol/L}$ ) for different time points (e.g., 3, 6, 12, 24 hours).
- **Cell Lysis:** Wash cells with ice-cold PBS and lyse them in RIPA buffer supplemented with protease and phosphatase inhibitors.
- **Protein Quantification:** Determine the protein concentration of the lysates using a BCA assay.
- **SDS-PAGE and Transfer:** Separate equal amounts of protein on an SDS-polyacrylamide gel and transfer to a PVDF membrane.
- **Immunoblotting:** Block the membrane with 5% non-fat milk or BSA in TBST. Incubate with primary antibodies against p-Akt, Akt, p-Erk, Erk, p-Stat3, and Stat3 overnight at 4°C. Use a loading control like GAPDH.
- **Detection:** Wash the membrane and incubate with an appropriate HRP-conjugated secondary antibody. Detect the signal using an enhanced chemiluminescence (ECL) substrate.

## Annexin V/PI Apoptosis Assay by Flow Cytometry

- Cell Preparation: Induce apoptosis in target cells with **Leelamine hydrochloride**. Include untreated and positive controls. Harvest both adherent and floating cells.
- Washing: Wash cells twice with cold PBS and then resuspend in 1X Binding Buffer at a concentration of  $1 \times 10^6$  cells/mL.
- Staining: Transfer 100  $\mu$ L of the cell suspension to a flow cytometry tube. Add 5  $\mu$ L of FITC-conjugated Annexin V and 5  $\mu$ L of Propidium Iodide (PI).
- Incubation: Gently vortex the cells and incubate for 15 minutes at room temperature in the dark.
- Analysis: Add 400  $\mu$ L of 1X Binding Buffer to each tube and analyze by flow cytometry within one hour.

## In Vivo Xenograft Model

- Cell Implantation: Subcutaneously inject a suspension of tumor cells (e.g.,  $2.5 \times 10^6$  UACC 903 cells) into the flank of immunocompromised mice.
- Tumor Growth Monitoring: Allow tumors to establish and reach a palpable size (e.g., 50-100  $\text{mm}^3$ ).
- Randomization and Treatment: Randomize mice into treatment and control groups. Administer **Leelamine hydrochloride** (e.g., 7.5 mg/kg body weight) or vehicle control intraperitoneally daily.
- Tumor Measurement: Measure tumor volume regularly (e.g., every other day) using calipers.
- Endpoint Analysis: At the end of the study, euthanize the mice and excise the tumors for further analysis (e.g., Western blotting, immunohistochemistry).

## Mandatory Visualizations

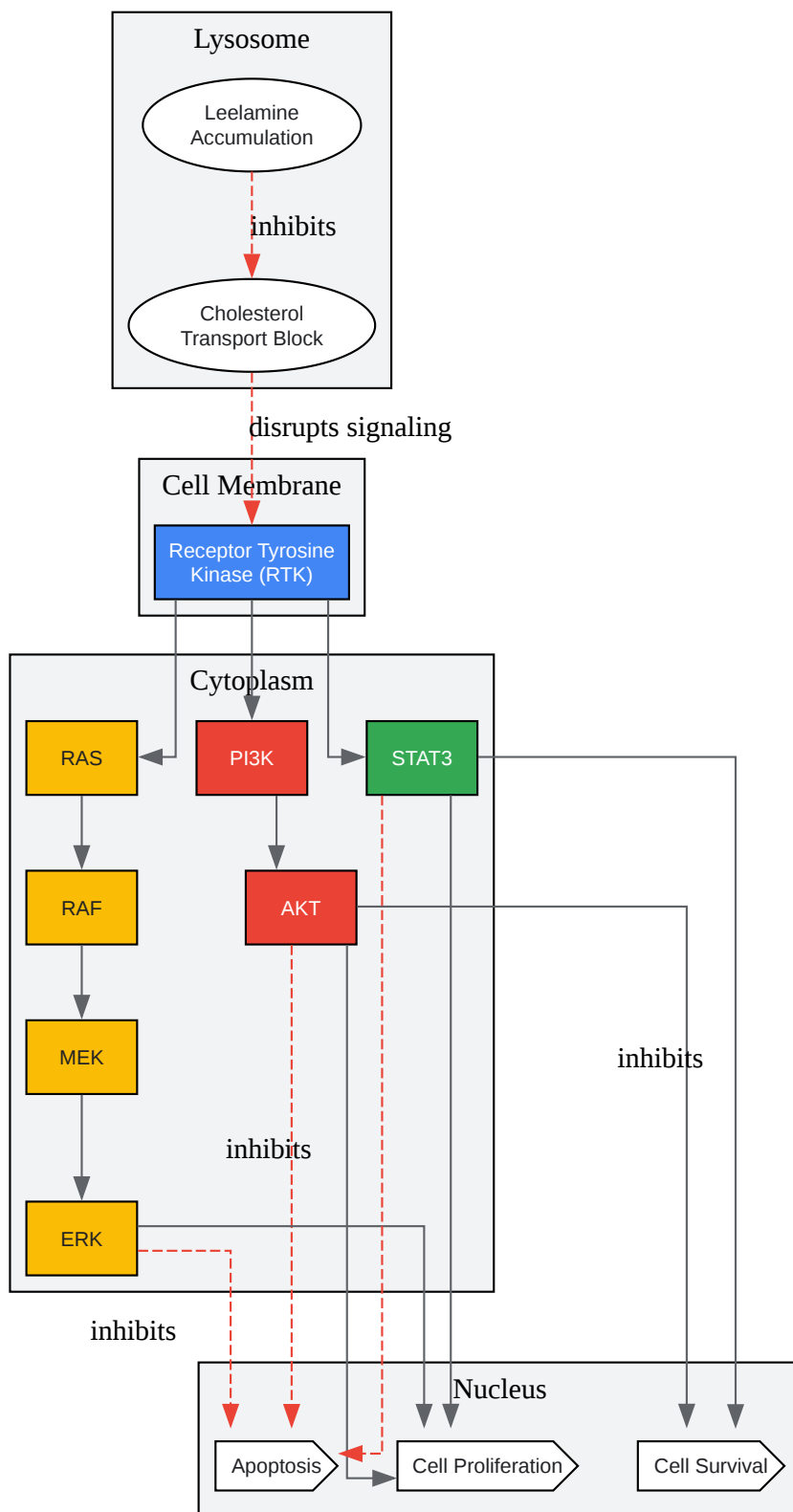

[Click to download full resolution via product page](#)

Caption: Leelamine's inhibition of cholesterol transport disrupts key oncogenic signaling pathways.

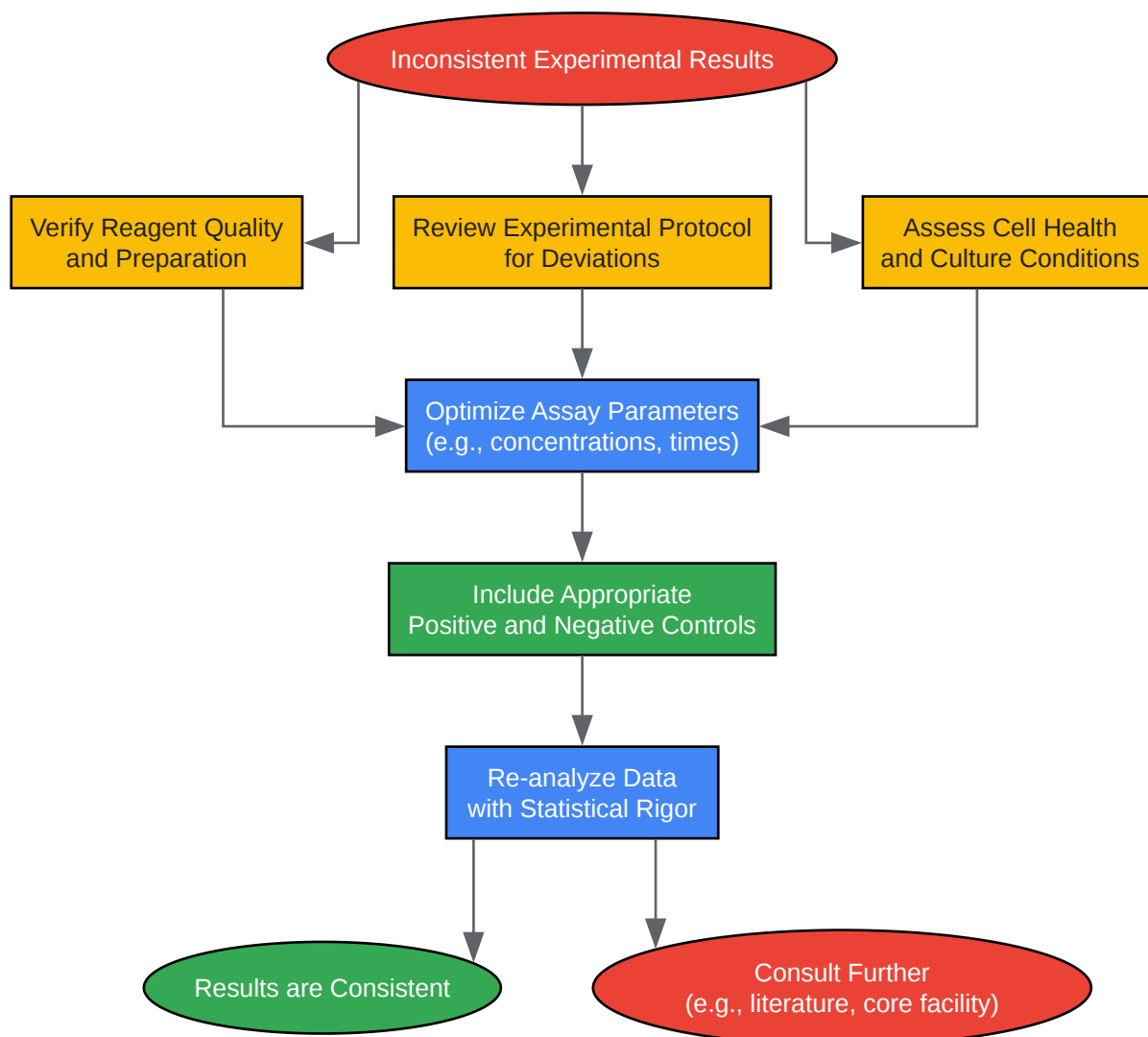

[Click to download full resolution via product page](#)

Caption: A logical workflow for troubleshooting inconsistent experimental results.

#### ***Need Custom Synthesis?***

*BenchChem offers custom synthesis for rare earth carbides and specific isotopic labeling.*

*Email: [info@benchchem.com](mailto:info@benchchem.com) or [Request Quote Online](#).*

## References

- [1. Identifying the structure-activity relationship of leelamine necessary for inhibiting intracellular cholesterol transport - PMC \[pmc.ncbi.nlm.nih.gov\]](#)
- [2. Leelamine mediates cancer cell death through inhibition of intracellular cholesterol transport - PubMed \[pubmed.ncbi.nlm.nih.gov\]](#)
- [3. oncotarget.com \[oncotarget.com\]](#)
- [4. benchchem.com \[benchchem.com\]](#)
- [5. Reddit - The heart of the internet \[reddit.com\]](#)
- [6. resources.rndsystems.com \[resources.rndsystems.com\]](#)
- [7. m.youtube.com \[m.youtube.com\]](#)
- [8. Western Blot Troubleshooting Guide - TotalLab \[totallab.com\]](#)
- [9. bosterbio.com \[bosterbio.com\]](#)
- [10. Western Blot Troubleshooting | Thermo Fisher Scientific - HK \[thermofisher.com\]](#)
- [11. Western blot troubleshooting guide! \[jacksonimmuno.com\]](#)
- [12. Western Blot Troubleshooting Guide | R&D Systems \[rndsystems.com\]](#)
- [13. yeasenbio.com \[yeasenbio.com\]](#)
- [14. bosterbio.com \[bosterbio.com\]](#)
- [15. benchchem.com \[benchchem.com\]](#)
- To cite this document: BenchChem. [Technical Support Center: Navigating Leelamine Hydrochloride Experiments]. BenchChem, [2026]. [Online PDF]. Available at: [\[https://www.benchchem.com/product/b11935780/docs#technical-support-center-navigating-leelamine-hydrochloride-experiments\]](https://www.benchchem.com/product/b11935780/docs#technical-support-center-navigating-leelamine-hydrochloride-experiments)

---

### Disclaimer & Data Validity:

The information provided in this document is for Research Use Only (RUO) and is strictly not intended for diagnostic or therapeutic procedures. While BenchChem strives to provide accurate protocols, we make no warranties, express or implied, regarding the fitness of this product for every specific experimental setup.

**Technical Support:** The protocols provided are for reference purposes. Unsure if this reagent suits your experiment?

**Need Industrial/Bulk Grade?** [Request Custom Synthesis Quote](#)

## BenchChem

Our mission is to be the trusted global source of essential and advanced chemicals, empowering scientists and researchers to drive progress in science and industry.

### Contact

Address: 3281 E Guasti Rd  
Ontario, CA 91761, United States  
Phone: (601) 213-4426  
Email: [info@benchchem.com](mailto:info@benchchem.com)

[Contact our Ph.D. Support Team for a compatibility check](#)