

Application Notes and Protocols for Azido-PEG13-acid Reactions

Author: BenchChem Technical Support Team. **Date:** April 2026

Compound of Interest

Compound Name: Azido-PEG13-acid

Cat. No.: B11935907

[Get Quote](#)

For Researchers, Scientists, and Drug Development Professionals

These application notes provide detailed protocols and experimental conditions for reactions involving **Azido-PEG13-acid**, a bifunctional linker widely used in bioconjugation, drug delivery, and nanotechnology. This document outlines the primary reaction types for this molecule: Copper-Catalyzed Azide-Alkyne Cycloaddition (CuAAC), Strain-Promoted Azide-Alkyne Cycloaddition (SPAAC), and amide bond formation.

Introduction to Azido-PEG13-acid

Azido-PEG13-acid is a heterobifunctional polyethylene glycol (PEG) linker. It possesses a terminal azide group ($-N_3$) and a terminal carboxylic acid group ($-COOH$), separated by a 13-unit PEG spacer. This structure allows for sequential or orthogonal conjugation strategies. The azide group participates in "click chemistry" reactions, offering a highly specific and efficient method for bioconjugation. The carboxylic acid can be activated to form stable amide bonds with primary amines. The hydrophilic PEG chain enhances solubility, reduces non-specific binding, and can improve the pharmacokinetic properties of the resulting conjugates.

Key Applications

- **Antibody-Drug Conjugates (ADCs):** The linker can be used to attach cytotoxic drugs to antibodies for targeted cancer therapy.
- **Nanoparticle Functionalization:** Modifying the surface of nanoparticles to improve their stability, biocompatibility, and targeting capabilities.[1]
- **Peptide and Protein Modification:** Site-specific PEGylation to enhance the therapeutic properties of proteins and peptides.
- **Surface Modification:** Creating biocompatible and functionalized surfaces for biosensors and other biomedical devices.

Storage and Handling

Azido-PEG13-acid should be stored at -20°C in a desiccated, dark environment to prevent degradation of the azide group. Before use, the reagent should be equilibrated to room temperature to avoid moisture condensation. For reactions, it is often recommended to prepare fresh solutions of the linker in a suitable anhydrous solvent like DMSO or DMF.

Reaction Chemistries and Protocols

Azido-PEG13-acid's utility stems from the distinct reactivity of its two terminal functional groups. The azide group is primarily used in click chemistry reactions, while the carboxylic acid is used for forming amide bonds.

Azide Group Reactions: Click Chemistry

Click chemistry provides a powerful and highly selective method for conjugating **Azido-PEG13-acid** to molecules containing an alkyne group.[2]

CuAAC is a highly efficient reaction that forms a stable triazole linkage between an azide and a terminal alkyne, catalyzed by a copper(I) species.[3]

Reaction Scheme:

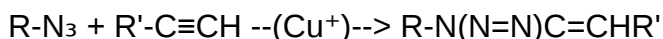

Quantitative Data for CuAAC Reactions

Parameter	Recommended Condition	Notes
Alkyne Reactant	Terminal Alkyne	Must be a terminal alkyne for the reaction to proceed.
Copper Source	CuSO ₄ (with a reducing agent)	Copper(II) sulfate is reduced in situ to the active Cu(I) catalyst.
Reducing Agent	Sodium Ascorbate	Used to reduce Cu(II) to Cu(I).
Cu(I) Ligand	THPTA or TBTA	Stabilizes the Cu(I) catalyst and protects biomolecules from oxidative damage.
Solvent	Aqueous buffers (e.g., PBS), DMF, DMSO	The choice of solvent depends on the solubility of the reactants.
Reactant Ratio	1.5 - 10 fold excess of one reactant	The more precious or limiting reactant should be used as the reference.
Temperature	Room Temperature	The reaction is typically efficient at ambient temperatures.
Reaction Time	1 - 4 hours	Can be longer for more complex or dilute reactants.
Typical Yield	>90%	CuAAC is known for its high yields and reaction efficiency. [3]

Experimental Protocol: CuAAC Conjugation of an Alkyne-Modified Peptide

- Reagent Preparation:
 - Prepare a 10 mM stock solution of **Azido-PEG13-acid** in anhydrous DMSO.
 - Prepare a 10 mM stock solution of the alkyne-modified peptide in an appropriate buffer (e.g., 0.1 M phosphate buffer, pH 7.0).

- Prepare a 50 mM stock solution of CuSO₄ in water.
- Prepare a 100 mM stock solution of Sodium Ascorbate in water (prepare fresh).
- Prepare a 50 mM stock solution of THPTA ligand in water.
- Reaction Setup:
 - In a microcentrifuge tube, combine the alkyne-modified peptide and **Azido-PEG13-acid** in the desired molar ratio (e.g., 1:5).
 - Add the THPTA ligand solution to the reaction mixture.
 - Add the CuSO₄ solution to the mixture.
 - Initiate the reaction by adding the freshly prepared sodium ascorbate solution.
- Incubation:
 - Gently mix the reaction and incubate at room temperature for 1-4 hours. The reaction can be monitored by LC-MS or HPLC.
- Purification:
 - Purify the conjugate using size-exclusion chromatography (SEC) or dialysis to remove unreacted reagents and byproducts.

SPAAC is a copper-free click chemistry reaction that utilizes a strained alkyne, such as dibenzocyclooctyne (DBCO), which reacts spontaneously with an azide. This method is ideal for applications in living systems where the cytotoxicity of copper is a concern.

Reaction Scheme:

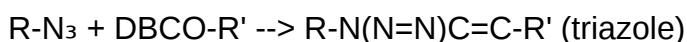

Quantitative Data for SPAAC Reactions

Parameter	Recommended Condition	Notes
Alkyne Reactant	Strained Alkyne (e.g., DBCO, BCN)	The ring strain of the alkyne drives the reaction.
Solvent	Aqueous buffers (e.g., PBS, HEPES), DMSO, DMF	Highly biocompatible reaction conditions.
Reactant Ratio	1.5 - 5 fold excess of one reactant	To drive the reaction to completion.
Temperature	Room Temperature or 37°C	Can be performed at physiological temperatures.
Reaction Time	2 - 24 hours	Generally slower than CuAAC.
Typical Yield	>85%	Highly efficient for a catalyst-free reaction.

Experimental Protocol: SPAAC Conjugation with a DBCO-labeled Protein

- Reagent Preparation:
 - Prepare a 10 mM stock solution of **Azido-PEG13-acid** in anhydrous DMSO.
 - Prepare the DBCO-labeled protein in a suitable buffer (e.g., PBS, pH 7.4). Ensure the buffer does not contain any azide preservatives.
- Reaction Setup:
 - Add the **Azido-PEG13-acid** stock solution to the DBCO-labeled protein solution. A 3-5 fold molar excess of the **Azido-PEG13-acid** is recommended. The final DMSO concentration should be kept below 10% to avoid protein denaturation.
- Incubation:
 - Incubate the reaction mixture for 4-12 hours at room temperature or overnight at 4°C with gentle mixing.
- Purification:

- Remove the excess **Azido-PEG13-acid** and purify the conjugate using size-exclusion chromatography or dialysis.

Carboxylic Acid Group Reaction: Amide Bond Formation

The carboxylic acid group of **Azido-PEG13-acid** can be coupled to primary amines using carbodiimide chemistry, typically with 1-Ethyl-3-(3-dimethylaminopropyl)carbodiimide (EDC) and N-hydroxysuccinimide (NHS) or its water-soluble analog (Sulfo-NHS).

Reaction Scheme:

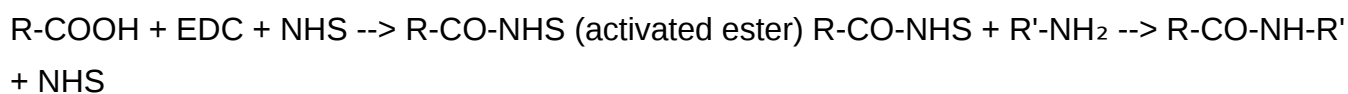

Quantitative Data for Amide Coupling Reactions

Parameter	Recommended Condition	Notes
Activating Agents	EDC and NHS (or Sulfo-NHS)	EDC activates the carboxyl group, and NHS forms a more stable amine-reactive intermediate.
Solvent	Anhydrous DMF or DMSO for stock, aqueous buffers for reaction	The reaction is typically performed in aqueous buffers.
pH	Activation: 4.5-6.0; Coupling: 7.2-8.0	Optimal pH for EDC activation is acidic, while the reaction with amines is more efficient at a slightly basic pH.
Molar Ratios	EDC:NHS:Azido-PEG13-acid = 5:2:1	These ratios can be optimized for specific applications.
Temperature	Room Temperature	The reaction proceeds efficiently at ambient temperature.
Reaction Time	Activation: 15-30 minutes; Coupling: 2-4 hours	The activated NHS ester can hydrolyze, so the amine should be added promptly after activation.
Typical Yield	60-85%	Yields can vary depending on the nature of the amine and reaction conditions.

Experimental Protocol: Amide Coupling to an Amine-Containing Molecule

- Reagent Preparation:
 - Prepare a 10 mg/mL stock solution of **Azido-PEG13-acid** in anhydrous DMF.
 - Prepare a 0.1 M MES buffer, pH 5.5 (Activation Buffer).

- Prepare a 0.1 M Phosphate Buffer, pH 7.4 (Coupling Buffer).
- Prepare EDC and NHS solutions immediately before use.
- Activation of Carboxylic Acid:
 - Dissolve **Azido-PEG13-acid** in the Activation Buffer.
 - Add a 5-fold molar excess of EDC and a 2-fold molar excess of NHS to the **Azido-PEG13-acid** solution.
 - Incubate for 15-30 minutes at room temperature to form the NHS ester.
- Conjugation to Amine:
 - Dissolve the amine-containing molecule in the Coupling Buffer.
 - Add the activated **Azido-PEG13-acid** solution to the amine-containing molecule solution.
 - Adjust the pH of the reaction mixture to 7.2-7.5 if necessary.
 - Incubate for 2-4 hours at room temperature with gentle mixing.
- Quenching and Purification:
 - Quench the reaction by adding a small molecule with a primary amine (e.g., Tris or glycine) to consume any unreacted NHS esters.
 - Purify the conjugate using dialysis, size-exclusion chromatography, or another appropriate method to remove unreacted materials and byproducts.

Visualized Workflows

The following diagrams illustrate common experimental workflows utilizing **Azido-PEG13-acid**.

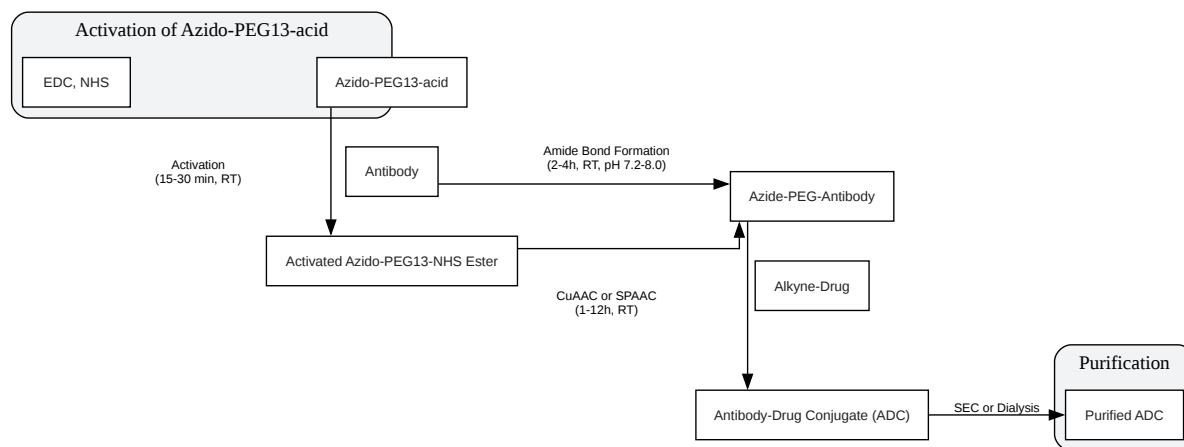

[Click to download full resolution via product page](#)

Caption: Workflow for Antibody-Drug Conjugate (ADC) Synthesis.

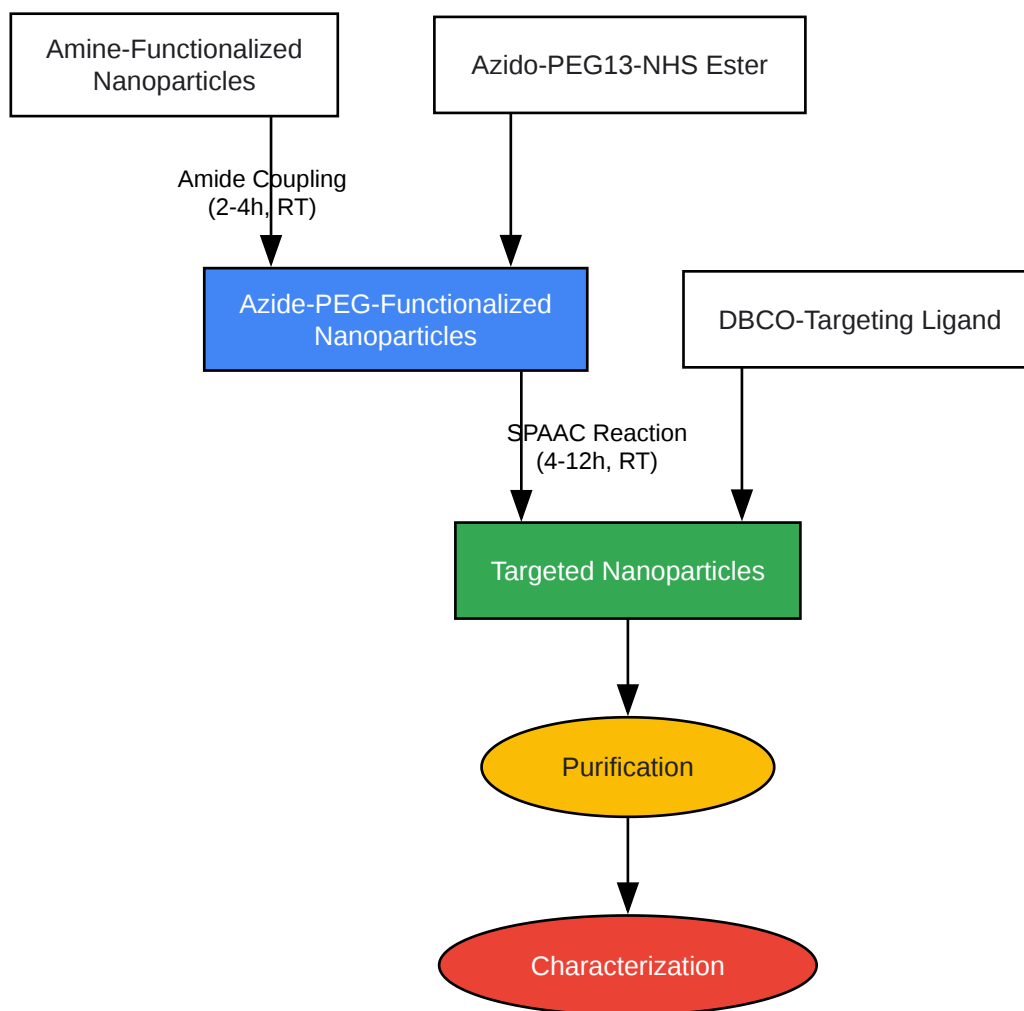

[Click to download full resolution via product page](#)

Caption: Functionalization of Nanoparticles for Targeted Delivery.

Need Custom Synthesis?

BenchChem offers custom synthesis for rare earth carbides and specific isotopic labeling.

Email: info@benchchem.com or [Request Quote Online](#).

References

- 1. Fabrication of azido-PEG-NHC stabilized gold nanoparticles as a functionalizable platform - PMC [[pmc.ncbi.nlm.nih.gov](https://pubmed.ncbi.nlm.nih.gov/)]
- 2. adc.bocsci.com [adc.bocsci.com]

- [3. mdpi.com \[mdpi.com\]](https://www.mdpi.com)
- To cite this document: BenchChem. [Application Notes and Protocols for Azido-PEG13-acid Reactions]. BenchChem, [2026]. [Online PDF]. Available at: [<https://www.benchchem.com/product/b11935907/docs#application-notes-and-protocols-for-azido-peg13-acid-reactions>]

Disclaimer & Data Validity:

The information provided in this document is for Research Use Only (RUO) and is strictly not intended for diagnostic or therapeutic procedures. While BenchChem strives to provide accurate protocols, we make no warranties, express or implied, regarding the fitness of this product for every specific experimental setup.

Technical Support: The protocols provided are for reference purposes. Unsure if this reagent suits your experiment?

Need Industrial/Bulk Grade? [Request Custom Synthesis Quote](#)

BenchChem

Our mission is to be the trusted global source of essential and advanced chemicals, empowering scientists and researchers to drive progress in science and industry.

Contact

Address: 3281 E Guasti Rd
Ontario, CA 91761, United States
Phone: (601) 213-4426
Email: info@benchchem.com

[Contact our Ph.D. Support Team for a compatibility check](#)