

Revolutionizing Super-Resolution Microscopy: A Guide to dSTORM Imaging with HM-JF526 NHS

Author: BenchChem Technical Support Team. **Date:** April 2026

Compound of Interest

Compound Name: HM-JF526 Nhs

Cat. No.: B11933719

[Get Quote](#)

Introduction: Unveiling the Potential of HM-JF526 NHS in dSTORM

Direct Stochastic Optical Reconstruction Microscopy (dSTORM) has emerged as a powerful super-resolution technique, enabling the visualization of cellular structures with unprecedented detail, far beyond the diffraction limit of light.[1][2] The choice of fluorophore is paramount to the success of dSTORM imaging.[3] This guide introduces **HM-JF526 NHS**, a fluorogenic, spontaneously blinking green-emitting dye, and provides a comprehensive framework for its application in dSTORM imaging.[4][5]

HM-JF526 NHS, a hydroxymethyl derivative of Janelia Fluor 526, possesses unique photophysical properties that make it exceptionally well-suited for single-molecule localization microscopy (SMLM) techniques like dSTORM.[4][6] A key advantage of HM-JF526 is its intrinsic ability to spontaneously blink, a phenomenon that can simplify the imaging workflow by potentially obviating the need for complex and harsh reducing agents in the imaging buffer.[4][5][7][8] This characteristic not only streamlines the experimental setup but also helps to preserve the intricate cellular structures under investigation.

This application note provides a detailed protocol for utilizing **HM-JF526 NHS** in dSTORM, from antibody conjugation to image acquisition and analysis. It is designed for researchers, scientists, and drug development professionals seeking to leverage the power of super-resolution microscopy for their investigations.

Core Principles: The Chemistry and Photophysics of HM-JF526 NHS

The utility of **HM-JF526 NHS** in dSTORM is rooted in two fundamental aspects: its amine-reactive N-hydroxysuccinimide (NHS) ester group and the spontaneous blinking of the HM-JF526 fluorophore.

The NHS ester facilitates the covalent conjugation of the dye to primary amines (-NH₂) present on proteins, most notably on lysine residues and the N-terminus of antibodies.^{[9][10][11]} This reaction forms a stable amide bond, ensuring a permanent label on the targeting molecule.^{[9][10]}

The spontaneous blinking of HM-JF526 arises from an equilibrium between a non-fluorescent "off" state and a fluorescent "on" state.^{[6][7]} This stochastic switching allows for the temporal separation of individual fluorophore emissions, a prerequisite for their precise localization in dSTORM.^[2]

Photophysical Properties of HM-JF526

Property	Value	Reference
Excitation Maximum (λ_{ex})	526 nm	[8]
Emission Maximum (λ_{em})	550 nm	[8]
Molecular Weight (NHS Ester)	645.51 g/mol	[4][5]
Reactive Group	N-hydroxysuccinimide (NHS) ester	
Reactivity	Primary amines	

Experimental Workflow: From Labeled Antibody to Super-Resolved Image

The successful application of **HM-JF526 NHS** in dSTORM imaging involves a multi-step process, beginning with the conjugation of the dye to a primary or secondary antibody, followed by immunolabeling of the target structure within the cell, and culminating in image acquisition and data analysis.

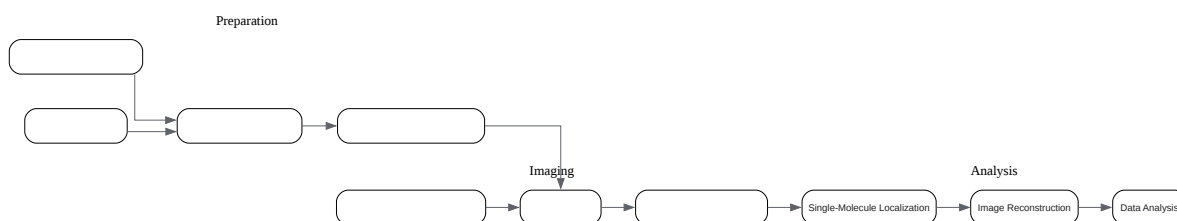

[Click to download full resolution via product page](#)

Figure 1. A schematic overview of the experimental workflow for dSTORM imaging using **HM-JF526 NHS**.

Part 1: Antibody Conjugation with HM-JF526 NHS

This protocol details the steps for covalently labeling an antibody with **HM-JF526 NHS**.

Materials:

- Purified antibody (1-10 mg/mL in an amine-free buffer like PBS)[10][12]
- **HM-JF526 NHS** ester

- Anhydrous Dimethyl Sulfoxide (DMSO)
- 1 M Sodium Bicarbonate (NaHCO₃), pH 8.3
- Quenching solution: 1.5 M Hydroxylamine, pH 8.5 or 1 M Tris-HCl, pH 8.0
- Purification column (e.g., size-exclusion chromatography or spin desalting column)
- Phosphate-Buffered Saline (PBS)

Protocol:

- Antibody Preparation:
 - Ensure the antibody is in an amine-free buffer (e.g., PBS). Buffers containing Tris or glycine will compete with the antibody for reaction with the NHS ester and must be removed.[\[11\]](#)
 - Adjust the antibody concentration to 2 mg/mL in PBS.[\[12\]](#)[\[13\]](#)
- **HM-JF526 NHS** Stock Solution Preparation:
 - Allow the vial of **HM-JF526 NHS** to equilibrate to room temperature before opening to prevent moisture condensation.
 - Prepare a 10 mg/mL stock solution of **HM-JF526 NHS** in anhydrous DMSO.[\[9\]](#)[\[13\]](#) This solution should be prepared fresh immediately before use.
- Conjugation Reaction:
 - Add 1/10th volume of 1 M sodium bicarbonate (pH 8.3) to the antibody solution to raise the pH, which is optimal for the NHS ester reaction.[\[9\]](#)
 - Add the **HM-JF526 NHS** stock solution to the antibody solution. A molar excess of 10-20 fold of dye to antibody is a good starting point. The optimal ratio may need to be determined empirically.
 - Incubate the reaction mixture for 1 hour at room temperature, protected from light.[\[9\]](#)

- Quenching the Reaction:
 - Add the quenching solution (e.g., 1 M Tris-HCl, pH 8.0) to a final concentration of 50-100 mM to stop the reaction by consuming any unreacted NHS ester.[10][13]
 - Incubate for 15-30 minutes at room temperature.[13]
- Purification of the Labeled Antibody:
 - Separate the labeled antibody from the unreacted dye and byproducts using a size-exclusion or spin desalting column, following the manufacturer's instructions.[9][12][13]
 - Elute the purified, labeled antibody in PBS.
- Determination of Degree of Labeling (DOL):
 - The DOL, the average number of dye molecules per antibody, can be determined spectrophotometrically by measuring the absorbance at 280 nm (for the antibody) and 526 nm (for HM-JF526).

Part 2: Cell Staining and Preparation for dSTORM Imaging

This section provides a general protocol for immunolabeling fixed cells.

Materials:

- Cells grown on high-precision coverslips
- Paraformaldehyde (PFA) for fixation
- Triton X-100 or Saponin for permeabilization
- Blocking buffer (e.g., 5% Bovine Serum Albumin (BSA) in PBS)
- Primary antibody (if using an unlabeled primary and a labeled secondary)
- **HM-JF526 NHS**-labeled secondary antibody

- Wash buffer (e.g., 0.1% BSA in PBS)

Protocol:

- Cell Fixation:
 - Fix cells with 4% PFA in PBS for 10-20 minutes at room temperature.[14]
 - Wash the cells three times with PBS.
- Permeabilization (for intracellular targets):
 - Permeabilize cells with 0.1% Triton X-100 in PBS for 10-15 minutes at room temperature.
 - Wash the cells three times with PBS.
- Blocking:
 - Block non-specific antibody binding by incubating the cells in blocking buffer for 1 hour at room temperature.[14]
- Primary Antibody Incubation (if applicable):
 - Dilute the primary antibody in blocking buffer to the recommended concentration.
 - Incubate the cells with the primary antibody solution for 1 hour at room temperature or overnight at 4°C.[3]
 - Wash the cells three times with wash buffer.
- Secondary Antibody Incubation:
 - Dilute the **HM-JF526 NHS**-labeled secondary antibody in blocking buffer.
 - Incubate the cells with the secondary antibody solution for 1 hour at room temperature, protected from light.
 - Wash the cells extensively with wash buffer and finally with PBS.

Part 3: dSTORM Imaging of HM-JF526 Labeled Samples

The spontaneous blinking of HM-JF526 simplifies the imaging buffer requirements. While traditional dSTORM often necessitates a GLOX (glucose oxidase and catalase) oxygen scavenging system and a thiol-containing reducing agent, these may not be strictly necessary for HM-JF526.^{[4][5][7][8][15]}

Simplified Imaging Buffer for HM-JF526:

A basic buffer such as PBS (pH 7.4) can be sufficient to observe the spontaneous blinking of HM-JF526.^{[7][16]} However, to optimize blinking kinetics and minimize photobleaching, a buffer containing an oxygen scavenger and a triplet-state quencher can be beneficial.

Recommended Imaging Buffer:

- 50 mM Tris-HCl, pH 8.0
- 10 mM NaCl
- 10% (w/v) Glucose
- 0.5 mg/mL Glucose Oxidase
- 40 µg/mL Catalase
- (Optional) 1-10 mM Mercaptoethylamine (MEA) as a reducing agent to potentially enhance blinking, though lower concentrations or its complete omission should be tested.

Image Acquisition:

- Mount the coverslip with the labeled cells onto a microscope slide with a small volume of the imaging buffer.
- Seal the sample to prevent buffer evaporation and oxygen re-entry.
- Use a dSTORM-capable microscope equipped with a high-power laser for excitation (e.g., 532 nm or 561 nm, depending on the microscope's laser lines and the excitation spectrum of

HM-JF526).

- Illuminate the sample with the excitation laser to induce photoswitching of the HM-JF526 molecules.
- Acquire a time-series of thousands of images (frames) to capture the stochastic blinking events of individual fluorophores. The exposure time and laser power should be optimized to achieve a low density of simultaneously fluorescing molecules per frame.[3]

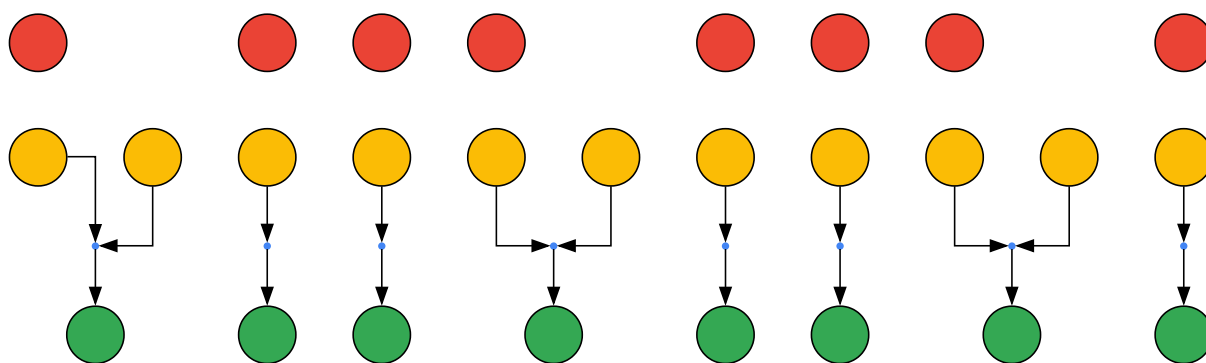

[Click to download full resolution via product page](#)

Figure 2. The principle of dSTORM imaging. A densely labeled structure is resolved by temporally separating the fluorescence of individual molecules.

Part 4: Data Analysis and Image Reconstruction

The acquired image stack is then processed to generate the final super-resolution image.

- **Single-Molecule Localization:** Each frame of the image stack is analyzed to identify and determine the precise coordinates of individual fluorescent events. This is typically achieved by fitting a 2D Gaussian function to the point spread function (PSF) of each blinking molecule.

- **Image Reconstruction:** The localized coordinates from all frames are compiled to reconstruct a final super-resolution image, where each localization is represented as a point.

Various open-source and commercial software packages are available for dSTORM data analysis, such as rapidSTORM, ThunderSTORM, or vendor-specific software.[2]

Troubleshooting and Optimization

- **Low Signal-to-Noise Ratio:** Increase laser power, optimize imaging buffer, or improve blocking during immunolabeling.
- **High Density of Blinking Events:** Reduce laser power or adjust the imaging buffer composition to decrease the "on" time of the fluorophores.
- **Photobleaching:** Ensure the imaging buffer has an efficient oxygen scavenging system. Minimize laser exposure when not acquiring data.

Conclusion

HM-JF526 NHS offers a compelling solution for dSTORM imaging, combining the ease of antibody conjugation with the advantage of spontaneous blinking. This simplifies the experimental workflow and provides a robust platform for achieving high-quality super-resolution images. By following the detailed protocols and understanding the core principles outlined in this guide, researchers can effectively employ **HM-JF526 NHS** to explore the intricate molecular landscape of their biological systems of interest.

References

- Fürth lab. (n.d.). This protocol outlines antibody conjugation by NHS-esters.
- abberior.rocks. (n.d.). NHS ester protocol for labeling proteins.
- BenchChem. (2025). Application Notes and Protocols: A Guide to Antibody Labeling with NHS Esters.
- Berg, E. A., & Fishman, J. B. (n.d.). Labeling Antibodies Using N-Hydroxysuccinimide (NHS)-Fluorescein. CSH Protocols.
- BroadPharm. (n.d.). General Protocol of Dye NHS Antibody Labeling Kit.
- MDPI. (2025). Pushing Optical Resolution to the Few-Nanometer Scale via dSTORM Imaging of Expanded Specimen–Gel Composites.

- Thermo Fisher Scientific. (n.d.). STORM Microscopy (Stochastic Optical Reconstruction Microscopy).
- ONI. (2025). dSTORM Imaging Buffer Preparation.
- ACS Publications. (2019). Rational Design of Fluorogenic and Spontaneously Blinking Labels for Super-Resolution Imaging. ACS Central Science.
- ResearchGate. (n.d.). Localization microscopy with HM-JF 526.
- MedKoo Biosciences. (n.d.). HM Janelia Fluor® 526, SE.
- PMC. (2013). Simple buffers for 3D STORM microscopy.
- ONI. (2023). Dos and Don'ts for mastering dSTORM imaging.
- bioRxiv. (2023). STORM imaging buffer with refractive index matched to standard immersion oil.
- YouTube. (2024). The Ins and Outs of Mastering dSTORM Imaging.
- YouTube. (2024). dSTORM for Beginners.
- Tocris Bioscience. (n.d.). HM Janelia Fluor® 526, NHS ester.
- Bio-Techne. (n.d.). Janelia Fluor® Dyes for Super Resolution Microscopy.
- PMC. (n.d.). Deep learning-driven automated high-content dSTORM imaging with a scalable open-source toolkit.
- Fisher Scientific. (n.d.). Tocris Bioscience HM Janelia Fluor 526, SE 1 mg.
- Tocris Bioscience. (n.d.). Janelia Fluor® 526, NHS ester.
- Tocris Bioscience. (n.d.). HM Janelia Fluor® 526, NHS ester.
- PMC. (n.d.). Rational Design of Fluorogenic and Spontaneously Blinking Labels for Super-Resolution Imaging.
- Xcess Biosciences. (n.d.). HM Janelia Fluor® 526, SE.
- ConnectSci. (2013). Focus on Super-Resolution Imaging with Direct Stochastic Optical Reconstruction Microscopy (dSTORM). Australian Journal of Chemistry.
- MedChemExpress. (n.d.). HM Janelia Fluor® 526, SE (**HM-JF526 NHS**).

Need Custom Synthesis?

BenchChem offers custom synthesis for rare earth carbides and specific isotopic labeling.

Email: info@benchchem.com or [Request Quote Online](#).

Sources

- [1. Janelia Fluor® Dyes for Super Resolution Microscopy | Bio-Techne \[bio-techne.com\]](#)
- [2. connectsci.au \[connectsci.au\]](#)

- [3. oni.bio \[oni.bio\]](#)
- [4. medkoo.com \[medkoo.com\]](#)
- [5. xcessbio.com \[xcessbio.com\]](#)
- [6. pubs.acs.org \[pubs.acs.org\]](#)
- [7. researchgate.net \[researchgate.net\]](#)
- [8. Tocris Bioscience HM Janelia Fluor 526, SE 1 mg | Buy Online | Tocris Bioscience™ | Fisher Scientific \[fishersci.ie\]](#)
- [9. NHS ester protocol for labeling proteins \[abberior.rocks\]](#)
- [10. pdf.benchchem.com \[pdf.benchchem.com\]](#)
- [11. Sign In \[cshprotocols.cshlp.org\]](#)
- [12. broadpharm.com \[broadpharm.com\]](#)
- [13. furthlab.xyz \[furthlab.xyz\]](#)
- [14. m.youtube.com \[m.youtube.com\]](#)
- [15. STORM Microscopy \(Stochastic Optical Reconstruction Microscopy\) | Thermo Fisher Scientific - HK \[thermofisher.com\]](#)
- [16. medchemexpress.com \[medchemexpress.com\]](#)
- [To cite this document: BenchChem. \[Revolutionizing Super-Resolution Microscopy: A Guide to dSTORM Imaging with HM-JF526 NHS\]. BenchChem, \[2026\]. \[Online PDF\]. Available at: \[https://www.benchchem.com/product/b11933719/docs#revolutionizing-super-resolution-microscopy-a-guide-to-dstorm-imaging-with-hm-jf526-nhs\]](#)

Disclaimer & Data Validity:

The information provided in this document is for Research Use Only (RUO) and is strictly not intended for diagnostic or therapeutic procedures. While BenchChem strives to provide accurate protocols, we make no warranties, express or implied, regarding the fitness of this product for every specific experimental setup.

Technical Support: The protocols provided are for reference purposes. Unsure if this reagent suits your experiment?

Need Industrial/Bulk Grade? [Request Custom Synthesis Quote](#)

BenchChem

Our mission is to be the trusted global source of essential and advanced chemicals, empowering scientists and researchers to drive progress in science and industry.

Contact

Address: 3281 E Guasti Rd

Ontario, CA 91761, United States

Phone: (601) 213-4426

Email: info@benchchem.com

[Contact our Ph.D. Support Team for a compatibility check](#)