

Technical Support Center: RGFP966 In Vivo Optimization

Author: BenchChem Technical Support Team. **Date:** April 2026

Compound of Interest

Compound Name: *Rgfp966*
CAS No.: 1357389-11-7
Cat. No.: B1193544

[Get Quote](#)

This technical support center provides troubleshooting guides and frequently asked questions (FAQs) for researchers utilizing the selective HDAC3 inhibitor, **RGFP966**, in in vivo studies. Our goal is to address common challenges and provide clear guidance for optimizing experimental design.

Frequently Asked Questions (FAQs)

Q1: What is the mechanism of action of **RGFP966**?

A1: **RGFP966** is a selective inhibitor of histone deacetylase 3 (HDAC3).[1][2][3] HDAC3 is a class I HDAC that plays a critical role in regulating gene expression by removing acetyl groups from histone and non-histone proteins.[4][5] Inhibition of HDAC3 by **RGFP966** leads to an increase in histone acetylation, which can alter gene transcription and has been shown to have anti-inflammatory and neuroprotective effects.[4][5][6][7] For instance, **RGFP966** has been demonstrated to attenuate NF-κB p65 transcriptional activity and activate the Nrf2 pathway.[4][5][6]

Q2: What is a typical starting dose for **RGFP966** in vivo?

A2: A common starting dose for **RGFP966** in rodents is 10 mg/kg administered via intraperitoneal (i.p.) or subcutaneous (s.c.) injection.[1][4][5] However, effective doses have been reported in the range of 2-10 mg/kg.[8] The optimal dose will depend on the animal model, the specific research question, and the desired therapeutic effect. A dose-response study is highly recommended to determine the most effective concentration for your specific experimental conditions.

Q3: How should I prepare **RGFP966** for in vivo administration?

A3: **RGFP966** has low aqueous solubility. A common method for preparation involves first dissolving it in a small amount of dimethyl sulfoxide (DMSO) and then diluting it with a vehicle such as polyethylene glycol (e.g., PEG300 or PEG400) and saline or a sodium acetate solution.[2][9] One reported formulation consists of 10% DMSO, 40% PEG300, 5% Tween 80, and 45% saline.[10] Another study used a vehicle of 75% polyethylene glycol 200 and 25% sodium acetate (6.25 mM).[2] For intravitreal injections, **RGFP966** has been dissolved in hydroxypropyl- β -cyclodextrin (HP β CD).[8]

Q4: What are the potential side effects or toxicity of **RGFP966**?

A4: At commonly used therapeutic doses (e.g., 10 mg/kg daily for 14 days), studies have reported no significant toxic or antiproliferative effects in off-target tissues in mice.[8] However, as with any compound, toxicity can be dose-dependent. It is crucial to monitor animals for any adverse effects, especially when using higher concentrations or longer treatment durations.

Troubleshooting Guide

Issue	Possible Cause	Suggested Solution
Poor compound solubility or precipitation	RGFP966 has low aqueous solubility. The chosen vehicle may not be optimal.	Ensure the initial stock is fully dissolved in DMSO before adding other vehicle components.[9] Consider using a co-solvent system like DMSO/PEG/saline.[9][10] Gentle warming and sonication can aid dissolution, but verify compound stability under these conditions.[9] For highly lipophilic compounds, an oil-based vehicle might be an alternative.[9]
Lack of efficacy or desired biological effect	The administered dose may be too low. The route or frequency of administration may not be optimal for the target tissue.	Conduct a dose-response study to determine the optimal concentration.[8] Consider the pharmacokinetic profile of RGFP966; it has been shown to penetrate the blood-brain barrier with peak concentrations in the retina observed within 1 hour of IP injection.[8][11] Adjust the dosing frequency based on the desired duration of target engagement.[8]
Observed toxicity or adverse events in animals	The administered dose may be too high. The vehicle itself may be causing adverse effects.	Reduce the dose of RGFP966. Administer a vehicle-only control group to rule out vehicle-induced toxicity. Carefully observe animals for signs of distress.

Quantitative Data Summary

Table 1: **RGFP966** In Vivo Dosages and Administration Routes

Animal Model	Dose Range	Route of Administration	Frequency	Reference
Mouse (Optic Nerve Crush)	2-10 mg/kg	Intraperitoneal (IP)	Daily or every 3 days	[8]
Mouse (Optic Nerve Crush)	1-10 μ M	Intravitreal	Single injection	[8]
Rat (Traumatic Brain Injury)	10 mg/kg	Intraperitoneal (IP)	Twice daily	[4][5]
Rat (Surgical Brain Injury)	10 mg/kg	Intraperitoneal (IP)	6h before and after injury	[12]
Mouse (Huntington's Disease Model)	10 mg/kg	Not specified	Not specified	[2]
Rat (Auditory Conditioning)	10 mg/kg	Subcutaneous (s.c.)	Post-training	[11]
Mouse (Allergic Rhinitis)	Not specified	Not specified	Not specified	[3]
Mouse (Diabetic Retinopathy)	10 mg/kg	Intraperitoneal (IP)	Every 3 days for 12 weeks	[7]
Mouse (db/db)	10 mg/kg	Subcutaneous (s.c.)	Every other day for 10 weeks	[7]

Experimental Protocols

Protocol 1: Preparation of **RGFP966** for Intraperitoneal Injection

Materials:

- **RGFP966** powder
- Dimethyl sulfoxide (DMSO)
- Polyethylene glycol 300 (PEG300)
- Tween 80
- Sterile saline (0.9% NaCl)
- Sterile microcentrifuge tubes
- Vortex mixer
- Sonicator (optional)

Procedure:

- Calculate the required amount of **RGFP966** and vehicle components based on the desired final concentration and injection volume. For a 10 mg/kg dose in a 25g mouse with an injection volume of 100 μ L, you would need a 2.5 mg/mL solution.
- Prepare the vehicle solution: 10% DMSO, 40% PEG300, 5% Tween 80, and 45% saline.[10] For 1 mL of vehicle, this would be 100 μ L DMSO, 400 μ L PEG300, 50 μ L Tween 80, and 450 μ L saline.
- Weigh the **RGFP966** powder and place it in a sterile microcentrifuge tube.
- Add the calculated volume of DMSO to the **RGFP966** powder and vortex until fully dissolved.
- Add the PEG300 and Tween 80 to the DMSO/**RGFP966** solution and vortex thoroughly.
- Slowly add the sterile saline to the mixture while vortexing to prevent precipitation.
- If necessary, gently warm the solution or sonicate to aid dissolution.
- Visually inspect the solution for any precipitates before administration.

Visualizations

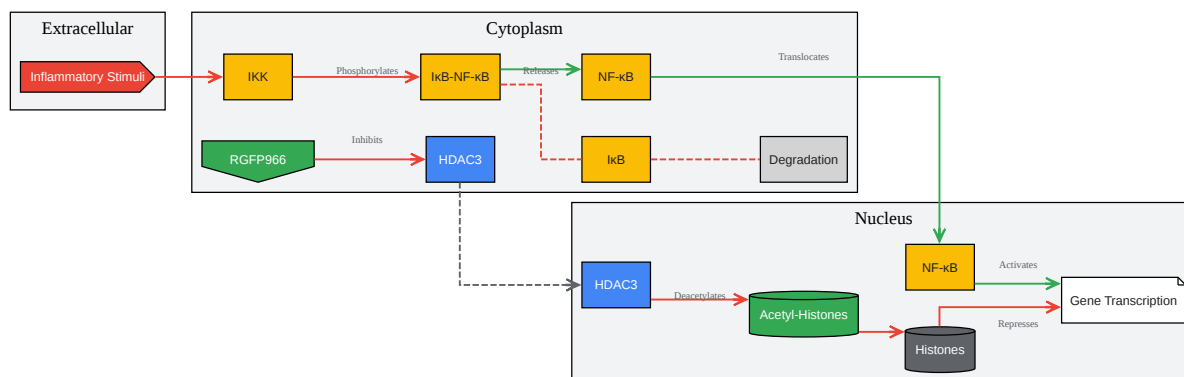

[Click to download full resolution via product page](#)

Caption: Simplified signaling pathway of HDAC3 in inflammation.

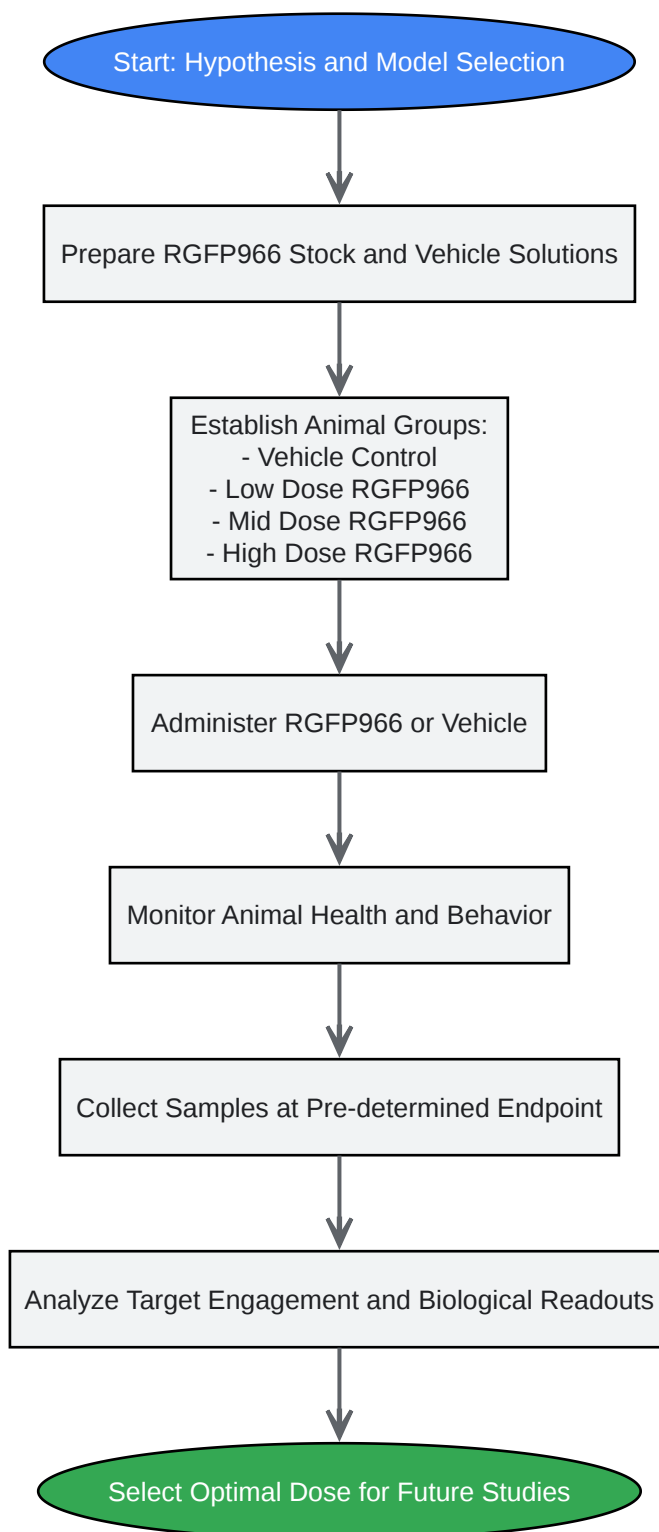

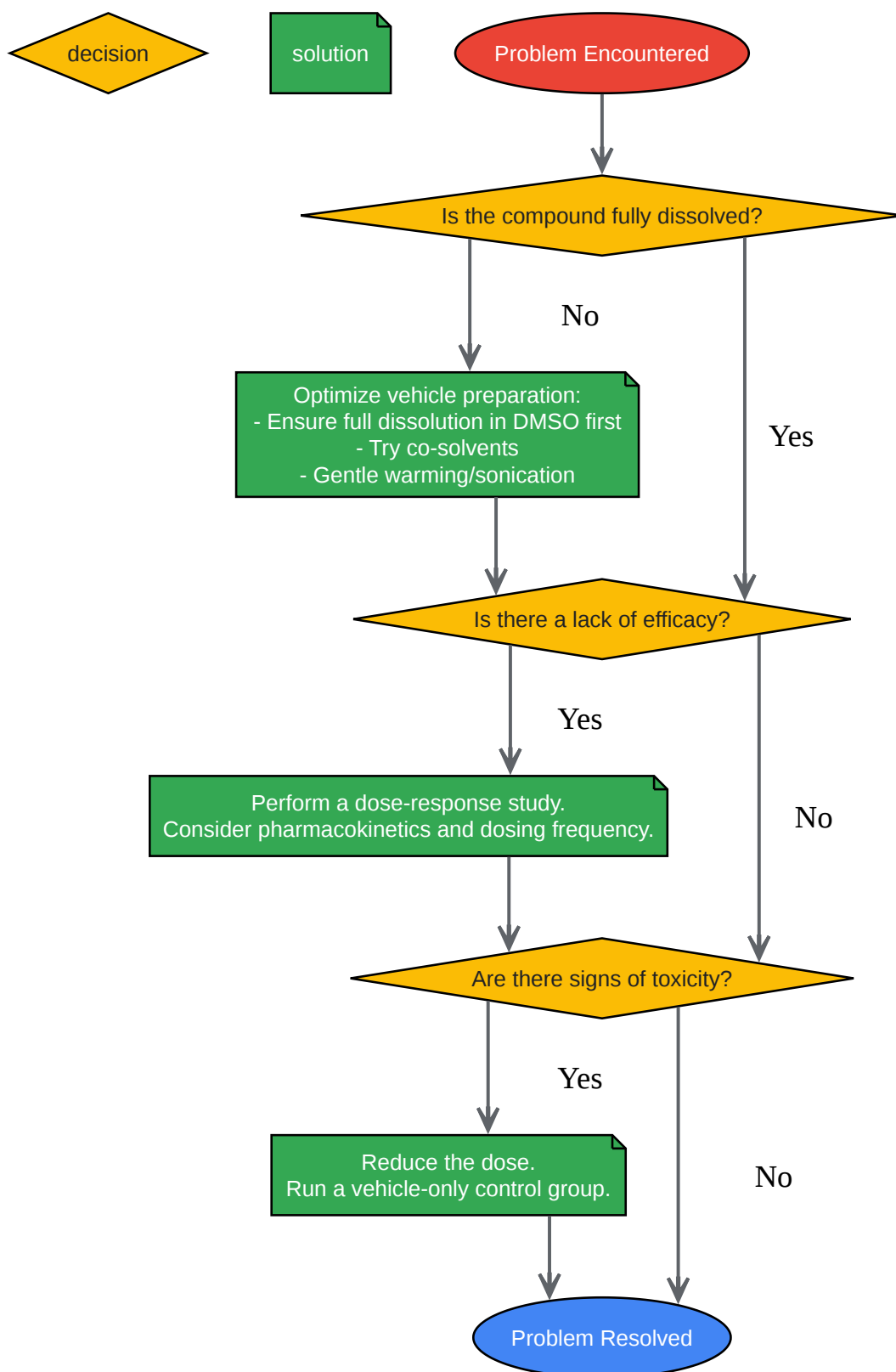

[Click to download full resolution via product page](#)

Need Custom Synthesis?

BenchChem offers custom synthesis for rare earth carbides and specific isotopic labeling.

Email: info@benchchem.com or [Request Quote Online](#).

References

- [1. selleckchem.com \[selleckchem.com\]](https://www.selleckchem.com)
- [2. medchemexpress.com \[medchemexpress.com\]](https://www.medchemexpress.com)
- [3. RGFP966, a selective HDAC3 inhibitor, ameliorates allergic and inflammatory responses in an OVA-induced allergic rhinitis mouse model - PubMed \[pubmed.ncbi.nlm.nih.gov\]](https://pubmed.ncbi.nlm.nih.gov)
- [4. academic.oup.com \[academic.oup.com\]](https://academic.oup.com)
- [5. Histone deacetylase 3-specific inhibitor RGFP966 attenuates oxidative stress and inflammation after traumatic brain injury by activating the Nrf2 pathway - PMC \[pmc.ncbi.nlm.nih.gov\]](https://pubmed.ncbi.nlm.nih.gov)
- [6. HDAC 3-selective inhibitor RGFP966 demonstrates anti-inflammatory properties in RAW 264.7 macrophages and mouse precision-cut lung slices by attenuating NF- \$\kappa\$ B p65 transcriptional activity - PMC \[pmc.ncbi.nlm.nih.gov\]](https://pubmed.ncbi.nlm.nih.gov)
- [7. alzdiscovery.org \[alzdiscovery.org\]](https://alzdiscovery.org)
- [8. Targeting HDAC3 Activity with RGFP966 Protects Against Retinal Ganglion Cell Nuclear Atrophy and Apoptosis After Optic Nerve Injury - PMC \[pmc.ncbi.nlm.nih.gov\]](https://pubmed.ncbi.nlm.nih.gov)
- [9. benchchem.com \[benchchem.com\]](https://www.benchchem.com)
- [10. RGFP966 | HDAC | TargetMol \[targetmol.com\]](https://www.targetmol.com)
- [11. Histone Deacetylase Inhibition via RGFP966 Releases the Brakes on Sensory Cortical Plasticity and the Specificity of Memory Formation - PMC \[pmc.ncbi.nlm.nih.gov\]](https://pubmed.ncbi.nlm.nih.gov)
- [12. RGFP966 exerts neuroprotective effect via HDAC3/Nrf2 pathway after surgical brain injury in rats - PMC \[pmc.ncbi.nlm.nih.gov\]](https://pubmed.ncbi.nlm.nih.gov)
- To cite this document: BenchChem. [Technical Support Center: RGFP966 In Vivo Optimization]. BenchChem, [2026]. [Online PDF]. Available at: [\[https://www.benchchem.com/product/b1193544/docs#technical-support-center-rgfp966-in-vivo-optimization\]](https://www.benchchem.com/product/b1193544/docs#technical-support-center-rgfp966-in-vivo-optimization)

Disclaimer & Data Validity:

The information provided in this document is for Research Use Only (RUO) and is strictly not intended for diagnostic or therapeutic procedures. While BenchChem strives to provide accurate protocols, we make no warranties, express or implied, regarding the fitness of this product for every specific experimental setup.

Technical Support: The protocols provided are for reference purposes. Unsure if this reagent suits your experiment?

Need Industrial/Bulk Grade? [Request Custom Synthesis Quote](#)

BenchChem

Our mission is to be the trusted global source of essential and advanced chemicals, empowering scientists and researchers to drive progress in science and industry.

Contact

Address: 3281 E Guasti Rd
Ontario, CA 91761, United States
Phone: (601) 213-4426
Email: info@benchchem.com

[Contact our Ph.D. Support Team for a compatibility check](#)