

Synthesis of triazole-linked bioconjugates using Propargyl-PEG9-azide

Author: BenchChem Technical Support Team. **Date:** May 2026

Compound of Interest

Compound Name: Propargyl-PEG9-azide

Cat. No.: B1193443

[Get Quote](#)

Application Note & Protocol

Facile Synthesis of Triazole-Linked Bioconjugates via Copper-Catalyzed Click Chemistry Using Propargyl-PEG9-azide

Abstract & Introduction

Bioconjugation, the covalent linking of biomolecules to other molecules, is a cornerstone of modern biotechnology, enabling the development of advanced therapeutics like antibody-drug conjugates (ADCs), sophisticated diagnostic tools, and targeted drug delivery systems.[1][2] Among the most powerful methods for creating these linkages is the Copper(I)-Catalyzed Azide-Alkyne Cycloaddition (CuAAC), a cornerstone of "click chemistry." [3][4] This reaction is prized for its high efficiency, specificity, and biocompatibility, proceeding rapidly under mild, aqueous conditions to form a stable triazole linkage.[5]

This guide provides a detailed framework for utilizing **Propargyl-PEG9-azide**, a heterobifunctional linker, to synthesize precisely defined bioconjugates. This linker is uniquely equipped with a terminal propargyl group and a terminal azide group, positioned at opposite

ends of a discrete nine-unit polyethylene glycol (PEG) chain.[6][7] The PEG spacer is not merely a connector; it imparts critical advantages, including enhanced aqueous solubility, reduced immunogenicity, and improved pharmacokinetic profiles of the final conjugate.[2][8][9] We will explore the underlying chemical principles, provide a robust, step-by-step protocol for a model conjugation, and detail methods for purification and characterization, empowering researchers to confidently apply this versatile tool in their work.

The Core Chemistry: Copper(I)-Catalyzed Azide-Alkyne Cycloaddition (CuAAC)

The CuAAC reaction is a highly reliable 1,3-dipolar cycloaddition between a terminal alkyne (like the propargyl group on our linker) and an azide. The reaction is not spontaneous and requires a copper(I) catalyst to proceed efficiently.[4][10] The catalyst orchestrates the formation of a stable 1,4-disubstituted 1,2,3-triazole ring, which serves as the inert and robust connection in the final bioconjugate.[10]

Why CuAAC is Ideal for Bioconjugation:

- **Bioorthogonality:** Azides and alkynes are largely absent in biological systems, meaning the reaction is highly specific and does not interfere with native cellular processes.[5]
- **Mild Conditions:** The reaction proceeds efficiently in aqueous buffers at room temperature, preserving the delicate three-dimensional structure and function of biomolecules like proteins and antibodies.[11]
- **High Yield & Favorable Kinetics:** The reaction is typically fast and high-yielding, simplifying the path to obtaining sufficient quantities of the desired bioconjugate.[3]

The standard CuAAC protocol involves a copper(II) source (e.g., CuSO_4) and a reducing agent (e.g., sodium ascorbate) to generate the active Cu(I) species in situ.[12] To prevent potential oxidative damage to sensitive biomolecules by reactive oxygen species generated under these conditions, and to enhance reaction kinetics, a stabilizing ligand such as Tris(3-hydroxypropyl)triazolylmethylamine (THPTA) is crucial.[3][11][12] The ligand protects the copper catalyst and the target biomolecule, ensuring a clean and efficient conjugation.[12]

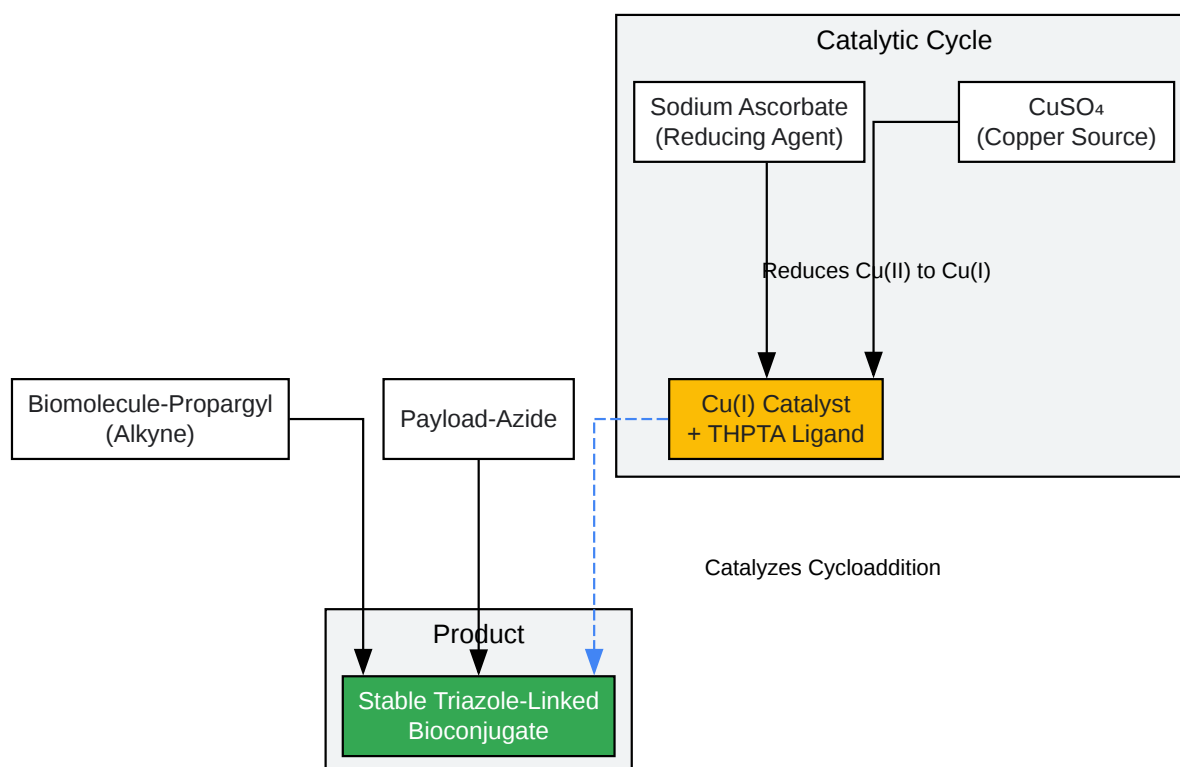

[Click to download full resolution via product page](#)

Caption: Structure of the **Propargyl-PEG9-azide** linker.

Experimental Protocol: Conjugation of an Alkyne-Modified Protein

This protocol details a general procedure for conjugating an azide-containing molecule (e.g., a small molecule drug, a peptide, or **Propargyl-PEG9-azide** itself) to a protein that has been pre-modified to contain a terminal alkyne group.

Materials and Reagents

- Alkyne-modified Protein (e.g., Antibody, Enzyme)
- Azide-containing Payload (e.g., **Propargyl-PEG9-azide**, Azido-Drug)

- Copper(II) Sulfate Pentahydrate ($\text{CuSO}_4 \cdot 5\text{H}_2\text{O}$)
- Sodium Ascorbate
- THPTA (Tris(3-hydroxypropyltriazolymethyl)amine)
- Phosphate-Buffered Saline (PBS), pH 7.4, degassed
- Dimethyl Sulfoxide (DMSO) or Dimethylformamide (DMF) for dissolving hydrophobic payloads
- Size Exclusion Chromatography (SEC) column for purification (e.g., Sephadex G-25, Superdex 200)
- Amicon® Ultra Centrifugal Filter Units (for buffer exchange and concentration)

Preparation of Stock Solutions

Causality Insight: Freshly prepared stock solutions are critical for reaction efficiency. Sodium ascorbate solutions are particularly susceptible to oxidation and should be made immediately before use.

- Alkyne-Protein: Prepare a solution of the alkyne-modified protein in degassed PBS at a concentration of 1-5 mg/mL.
- Azide-Payload: Dissolve the azide-payload in DMSO or PBS to a final concentration of 10-20 mM.
- Copper(II) Sulfate: Prepare a 100 mM stock solution in deionized water. [5]4. THPTA Ligand: Prepare a 200 mM stock solution in deionized water. [5]5. Sodium Ascorbate: Prepare a 100 mM stock solution in deionized water immediately before starting the conjugation. [5]

Step-by-Step Conjugation Workflow

Causality Insight: The order of addition is important. The copper and ligand should be pre-mixed to form the complex before being added to the protein. The reaction is initiated by the addition of the reducing agent, sodium ascorbate. [5]

- In a microcentrifuge tube, combine the Alkyne-Protein solution with the Azide-Payload. A 5 to 20-fold molar excess of the azide-payload over the protein is a good starting point for optimization.
- In a separate tube, prepare the copper catalyst solution by mixing the CuSO₄ and THPTA stock solutions in a 1:2 molar ratio. [5] Let this mixture stand for 2-3 minutes to allow for complex formation.
- Add the Cu(I)/THPTA complex to the protein/azide mixture. The final concentration of copper should be between 0.5 mM and 1.0 mM.
- Initiate the reaction by adding the freshly prepared sodium ascorbate solution. The final concentration should be between 2 mM and 5 mM (approx. 4-5 equivalents relative to copper). [12]5. Mix the reaction gently by inversion or by using a rotator. Do not vortex, as this can denature the protein.
- Incubate the reaction at room temperature for 1-4 hours, protected from light. [5] Reaction progress can be monitored by LC-MS if desired.

Example Reaction Setup

Reagent	Stock Concentration	Volume to Add	Final Concentration (in 500 μ L)	Molar Equivalents
Alkyne-Protein (150 kDa)	3 mg/mL (20 μ M)	400 μ L	16 μ M	1
Azide-Payload	10 mM	16 μ L	320 μ M	20
CuSO ₄	100 mM	5 μ L	1 mM	~63
THPTA	200 mM	5 μ L	2 mM	~125
Sodium Ascorbate	100 mM	25 μ L	5 mM	~313
PBS (to final volume)	-	49 μ L	-	-
Total Volume	500 μ L			

Purification and Characterization

Purification is essential to remove unreacted payload, copper catalyst, and other reagents from the final bioconjugate. [13] Characterization confirms the success of the conjugation and determines the purity and integrity of the product. [14]

Purification Methods

Size Exclusion Chromatography (SEC) is the most common method for purifying PEGylated proteins, as it effectively separates the larger bioconjugate from smaller reactants based on hydrodynamic radius. [15][16]

Method	Principle	Application	Advantages	Disadvantages
Size Exclusion Chromatography (SEC)	Separation based on molecular size.	Removes unreacted small molecules (payload, catalyst, ascorbate).	Mild conditions, preserves protein activity. [16]	Cannot separate unconjugated protein from singly-conjugated protein easily.
Ion Exchange Chromatography (IEX)	Separation based on net surface charge.	Can separate species with different numbers of conjugated molecules (if payload alters charge).	High resolution. [16]	PEG chains can shield charges, making separation challenging. [16]
Hydrophobic Interaction (HIC)	Separation based on hydrophobicity.	Can be a useful secondary purification step.	Orthogonal to SEC and IEX. [15]	Lower capacity and resolution can be an issue. [16]

| Affinity Chromatography | Separation based on specific binding interactions. | Ideal for purifying antibodies (e.g., Protein A/G). | High specificity and purity. | Requires a specific affinity

tag/ligand. |

Characterization Techniques

A combination of techniques is necessary to fully characterize the final product. [14]

Technique	Information Provided	Key Insights
SDS-PAGE	Apparent molecular weight, Purity.	Successful conjugation results in a band shift to a higher apparent molecular weight.
Mass Spectrometry (ESI-MS, MALDI-TOF)	Exact molecular weight, Drug-to-Antibody Ratio (DAR).	Confirms covalent attachment and determines the number of payloads per protein. [14]
HPLC (Reversed-Phase, SEC)	Purity, Aggregation, DAR.	Quantifies the percentage of pure conjugate and detects aggregates or fragments. [14] [16]

| UV-Vis Spectroscopy | Protein concentration, DAR (if payload has a chromophore). | A simple method for determining protein concentration and estimating conjugation efficiency. |

Troubleshooting

Problem	Possible Cause(s)	Suggested Solution(s)
Low Conjugation Efficiency	- Inactive azide/alkyne groups.- Oxidized sodium ascorbate.- Insufficient excess of payload.- Protein aggregation.	- Use fresh, high-quality reagents.- Prepare sodium ascorbate solution immediately before use.- Increase the molar excess of the azide-payload.- Ensure protein is soluble and monodisperse before starting.
Protein Precipitation	- High concentration of organic co-solvent (e.g., DMSO).- Copper-mediated aggregation.	- Keep the percentage of organic solvent below 10% (v/v).- Ensure the correct ligand-to-copper ratio ($\geq 2:1$) is used.
Broad Peaks in Chromatography	- Product heterogeneity.- Interaction with column matrix.	- Optimize reaction to favor a single species (e.g., lower payload excess).- Use a different chromatography resin or modify buffer conditions (e.g., add salt).

References

- Copper-Catalyzed Azide–Alkyne Click Chemistry for Bioconjugation. (n.d.). PMC.
- PEG Linkers Explained: Types, Uses, and Why They Matter in Bioconjugation. (2024, September 24). AxisPharm.
- How to Choose Proper PEG Linkers for Bioconjugation: Hints and Best Practices. (n.d.). Precise PEG.
- Top 5 Applications of PEGylated Linkers in Bioconjugation. (2025, July 1). PurePEG.
- The Strategic Role of PEG Linkers in Bioconjugation: An In-depth Technical Guide. (2025). BenchChem.
- Alkyne Azide Click Chemistry Protocol for ADC Bioconjugation with Real Examples. (2024, September 23). AxisPharm.
- Copper-Catalyzed Azide-Alkyne Click Chemistry for Bioconjugation. (n.d.). ResearchGate.
- PEG Linkers: Structure, Applications & Contributions. (2023, November 8). Creative PEGWorks.

- Copper-Catalyzed Azide--Alkyne Click Chemistry for Bioconjugation. (2011, December 15). Jena Bioscience.
- Practical Considerations for the Preparation and MS Analysis of PEGylated Bioconjugates. (n.d.). Quanta BioDesign.
- **Propargyl-PEG9-azide** | Alkyne PEG Linker. (n.d.). MedKoo Biosciences.
- CuAAC: Copper-Catalyzed Click Reaction. (n.d.). BOC Sciences.
- Application Notes and Protocols: Synthesis of Heterobifunctional Linkers using Propargyl-PEG9-bromide. (2025). BenchChem.
- PEGylation. (n.d.). Bio-Synthesis, Inc.
- Protein conjugates purification and characterization. (n.d.). ResearchGate.
- From Synthesis to Characterization of Site-Selective PEGylated Proteins. (2019, December 18). Frontiers in Bioengineering and Biotechnology.
- PEGylated Protein Purification Techniques. (n.d.). BOC Sciences.
- Propargyl PEG, Click Chemistry Tool. (n.d.). BroadPharm.
- Propargyl PEG | Alkyne PEG, Click Chemistry Linkers. (n.d.). AxisPharm.
- Triazolyl Glycoconjugates and their Impact in Medicinal Chemistry. (2016, September 29). TSI Journals.
- Synthesis of Propargyl-Terminated Heterobifunctional Poly(ethylene glycol). (2010, October 13). MDPI.
- Synthesis of 1,2,3-triazole derivatives based on propargyl ester of a saturated single-basic carbonic acid and para-azidobenzoic. (2021, March 31). ResearchGate.

Need Custom Synthesis?

BenchChem offers custom synthesis for rare earth carbides and specific isotopic labeling.

Email: info@benchchem.com or [Request Quote Online](#).

Sources

- [1. precisepeg.com](https://www.precisepeg.com) [[precisepeg.com](https://www.precisepeg.com)]
- [2. pdf.benchchem.com](https://pdf.benchchem.com) [pdf.benchchem.com]
- [3. researchgate.net](https://www.researchgate.net) [[researchgate.net](https://www.researchgate.net)]
- [4. bioconjugation.bocsci.com](https://www.bioconjugation.bocsci.com) [[bioconjugation.bocsci.com](https://www.bioconjugation.bocsci.com)]
- [5. Alkyne Azide Click Chemistry Protocol for ADC Bioconjugation with Real Examples | AxisPharm](#) [[axispharm.com](https://www.axispharm.com)]

- [6. medkoo.com \[medkoo.com\]](#)
- [7. benchchem.com \[benchchem.com\]](#)
- [8. PEG Linkers Explained: Types, Uses, and Why They Matter in Bioconjugation | AxisPharm \[axispharm.com\]](#)
- [9. creativepegworks.com \[creativepegworks.com\]](#)
- [10. eurjchem.com \[eurjchem.com\]](#)
- [11. jenabioscience.com \[jenabioscience.com\]](#)
- [12. Copper-Catalyzed Azide–Alkyne Click Chemistry for Bioconjugation - PMC \[pmc.ncbi.nlm.nih.gov\]](#)
- [13. PEGylation - Bio-Synthesis, Inc. \[biosyn.com\]](#)
- [14. repositorio.usp.br \[repositorio.usp.br\]](#)
- [15. researchgate.net \[researchgate.net\]](#)
- [16. peg.bocsci.com \[peg.bocsci.com\]](#)
- To cite this document: BenchChem. [Synthesis of triazole-linked bioconjugates using Propargyl-PEG9-azide]. BenchChem, [2026]. [Online PDF]. Available at: [<https://www.benchchem.com/product/b1193443/docs#synthesis-of-triazole-linked-bioconjugates-using-propargyl-peg9-azide>]

Disclaimer & Data Validity:

The information provided in this document is for Research Use Only (RUO) and is strictly not intended for diagnostic or therapeutic procedures. While BenchChem strives to provide accurate protocols, we make no warranties, express or implied, regarding the fitness of this product for every specific experimental setup.

Technical Support: The protocols provided are for reference purposes. Unsure if this reagent suits your experiment?

Need Industrial/Bulk Grade? [Request Custom Synthesis Quote](#)

BenchChem

Our mission is to be the trusted global source of essential and advanced chemicals, empowering scientists and researchers to drive progress in science and industry.

Contact

Address: 3281 E Guasti Rd
Ontario, CA 91761, United States
Phone: (601) 213-4426
Email: info@benchchem.com

[Contact our Ph.D. Support Team for a compatibility check](#)